

CUSTOMER : _____.

DATE : 2017. 01. 12 .

REV : Rev D .

PRODUCT FAMILY DATA SHEET

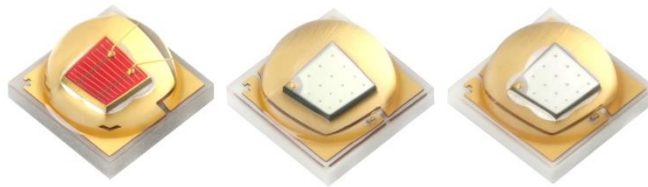

High Power Red, Green, Blue LED series 3535 Ceramic

MODEL NAME : LERRN31W *** *****

MODEL NAME : LEGGA31X *** *****

MODEL NAME : LEBBA31Q *** *****



APPROVAL	REMARK	APPENDIX

DESIGNED	CHECKED	APPROVED

TABLE OF CONTENTS

1. Features	-----	2
2. Applications	-----	2
3. Outline Dimensions	-----	2
4. Absolute Maximum Ratings	-----	3
5. Electro-Optical Characteristics	-----	3~4
6. Flux Bins and Order Code	-----	5
7. Typical Characteristic Curves	-----	6~11
8. Reliability Test Items and Conditions	-----	12~13
9. Packing and Labeling of Products	-----	14~17
10. Cautions on Use	-----	18~21
11. Disclaimers	-----	21
12. Package Nomenclature	-----	22
Change History of Revision	-----	23

1. Features

- Lighting Color : Red, Green, Blue
- Lead Frame Type LED Package : 3.40 x 3.40 x 2.37 (L x W x H) [Unit : mm]
- Viewing Angle : Red-Orange / Red / Hyper Red / Green / Royal Blue / Blue 120°
- Soldering Methods : Reflow soldering
- ESD Withstand Voltage : Up to 8kV According to JS-001

2. Applications

- Street lamp, Interior and Exterior Illumination

3. Outline Dimensions

(Unit : mm)

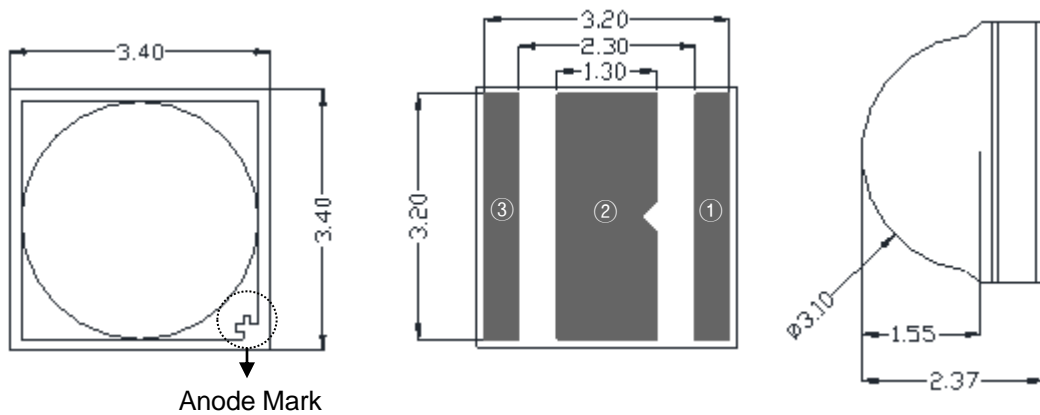

Recommendable Soldering Pattern
(for Reflow Soldering)

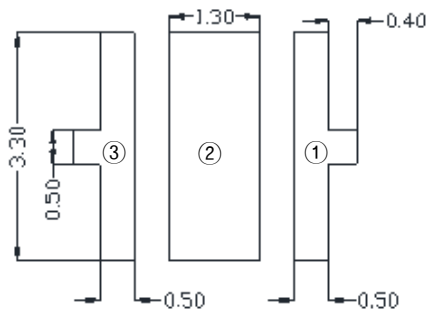
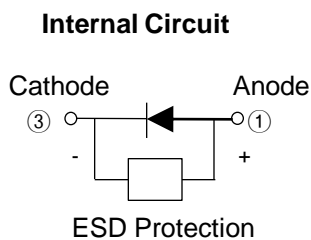

Pad Configuration

- ① Anode Pad
- ② Thermal Pad
- ③ Cathode Pad

Tolerances unless otherwise mentioned are ± 0.13 mm

4. Absolute Maximum Ratings

(Ta=25°C)

Item	Symbol	Rating	Unit
Forward Current - Red	If	800	mA
Forward Current - Green	If	800	mA
Forward Current - Blue	If	1000	mA
Operating Temperature	Topr	-40 ~ +85	°C
Storage Temperature	Tstg	-40 ~ +100	°C
Junction Temperature	Tj	150	°C
Soldering Temperature	JEDEC-J-STD-020D		
ESD Classification	Class 3B (JS-001)		

- ※ Operating the LED beyond the listed maximum ratings may affect device reliability and cause permanent damage. These or any other conditions beyond those indicated under recommended operating conditions are not implied. The exposure to the absolute maximum rated conditions may affect device reliability.
- ※ The LEDs are not designed to be driven in reverse bias.

5. Electro - Optical Characteristics

(Ta=25°C , If=350mA)

Color	Item	Symbol	Min.	Typ.	Max.	Unit
Red-Orange	Luminous Flux	Φ_v	-	89	-	lm
	Forward Voltage	Vf	1.95	2.21	2.60	V
	Dominant Wavelength	Wd	610	-	632	nm
Red	Thermal Resistance (Junction to Solder Point)	Rth j-s	-	7	-	°C/W
	Viewing Angle	2 Θ 1/2	-	120	-	deg
Green	Luminous Flux	Φ_v	-	109	-	lm
	Forward Voltage	Vf	3.00	3.20	3.60	V
	Dominant Wavelength	Wd	515	-	535	nm
	Thermal Resistance (Junction to Solder Point)	Rth j-s	-	14	-	°C/W
	Viewing Angle	2 Θ 1/2	-	120	-	deg
Royal Blue	Radiometric Power	Po	-	570	-	mW
	Forward Voltage	Vf	2.80	3.05	3.40	V
	Dominant Wavelength	Wd	445	452	465	nm
	Thermal Resistance (Junction to Solder Point)	Rth j-s	-	7	-	°C/W
	Viewing Angle	2 Θ 1/2	-	120	-	deg

- ※ These values are measured by the LG Innotek optical spectrum analyzer within the following tolerances. Luminous Flux (Φ_v) : $\pm 7\%$, Forward Voltage (Vf) : $\pm 0.1V$, Dominant Wavelength (Wd) : $\pm 1nm$,
- ※ Although all LEDs are tested by LG Innotek equipment, some values may vary slightly depending on the conditions of the test equipment.

5. Electro - Optical Characteristics (Continued)

(Ta=25°C)

Color	If (mA)	Vf (V)	WD (nm)	Φ_v (lm)
Red-Orange	350	2.21	610	89
	500	2.34	611	126
Red	800	2.58	611	201

Color	If (mA)	Vf (V)	WD (nm)	Po (mW)
Hyper Red	350			
	500		T.B.D	
	800			

Color	If (mA)	Vf (V)	WD (nm)	Φ_v (lm)
Green	350	3.20	527	109
	500	3.29	525	139
	800	3.45	521	186

Color	If (mA)	Vf (V)	WD (nm)	Po (mW)
Royal Blue	350	2.91	456	570
	700	3.11	456	1025
	1000	3.25	455	1370

Color	If (mA)	Vf (V)	WD (nm)	Φ_v (lm)
Blue	350			
	700		T.B.D	
	1000			

※ All the values in this table are for representative references only.

6. Flux Bins and Order Code

Flux, Wavelength Bins

(Ta=25°C , If=350mA)

Color	Luminous Flux [lm] or Radiometric Power [mW]			Dominant Wavelength [nm] or Peak Wavelength [nm]			Order Code
	@350mA			@350mA			
	Bin Code	Min.	Max.	Bin Code	Min.	Max.	
Red-Orange	R6	70	80	RW1	610	615	LERRN31W**AYZ000
	R7	80	90	RW2	615	620	
Red	R8	90	100	RW3	620	625	
	R9	100	115	RW4	625	630	
Hyper-Red	T.B.D			RW6	655	660	LEHRN31W**AYZ000
	T.B.D			RW7	660	665	
Green	G2	90	100	GW2	515	520	LEGGA31X**AYZ000
	G3	100	115	GW3	520	525	
	G4	115	130	GW4	525	530	
	G5	130	145	GW5	530	535	
Royal Blue	B1	520	560	BW1	445	450	LEBBA31Q**AYZ000
	B2	560	600	BW2	450	455	
	B3	600	640	BW3	455	460	
	B4	640	680				
Blue	T.B.D			BW4	460	465	
	T.B.D			BW5	465	470	

※ All the wavelength values in this table are Dominant Wavelength, except of Hyper-Red (Peak wavelength)

※ All the flux values in this table are Luminous Flux, except of Hyper-Red and Royal Blue (Radiometric Power)

Forward Voltage Bins

(Ta=25°C , If=350mA)

Color						Bin	Vf (V)	
Red-Orange	Red	Hyper-Red	Green	Royal Blue	Blue		Min.	Max.
○	○	○				b	1.95	2.3
○	○	○				c	2.3	2.6
						8	2.6	2.8
				○	○	0	2.8	3.0
			○	○	○	2	3.0	3.2
			○	○	○	4	3.2	3.4
			○			6	3.4	3.6

7. Typical Characteristic Curves

- Forward Current vs. Forward Voltage

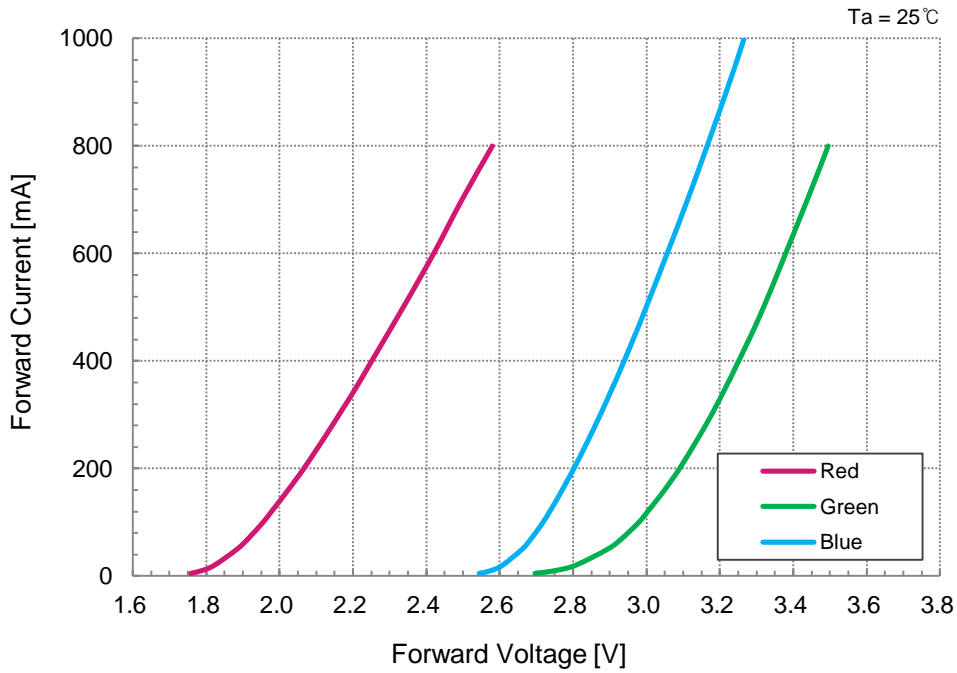

- Relative Luminous Flux vs. Forward Current

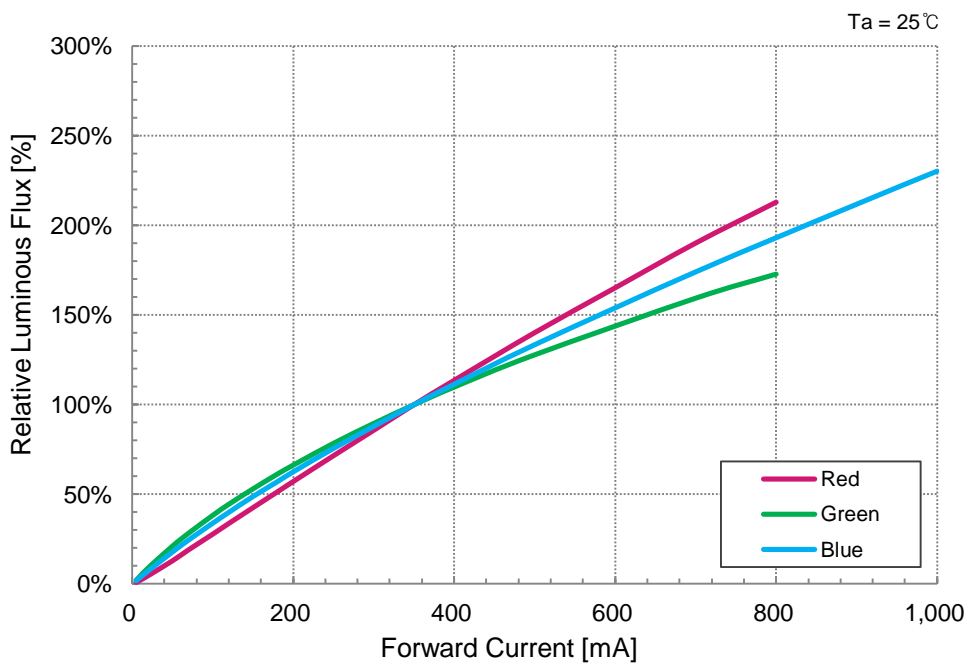

7. Typical Characteristic Curves

- Spectrum

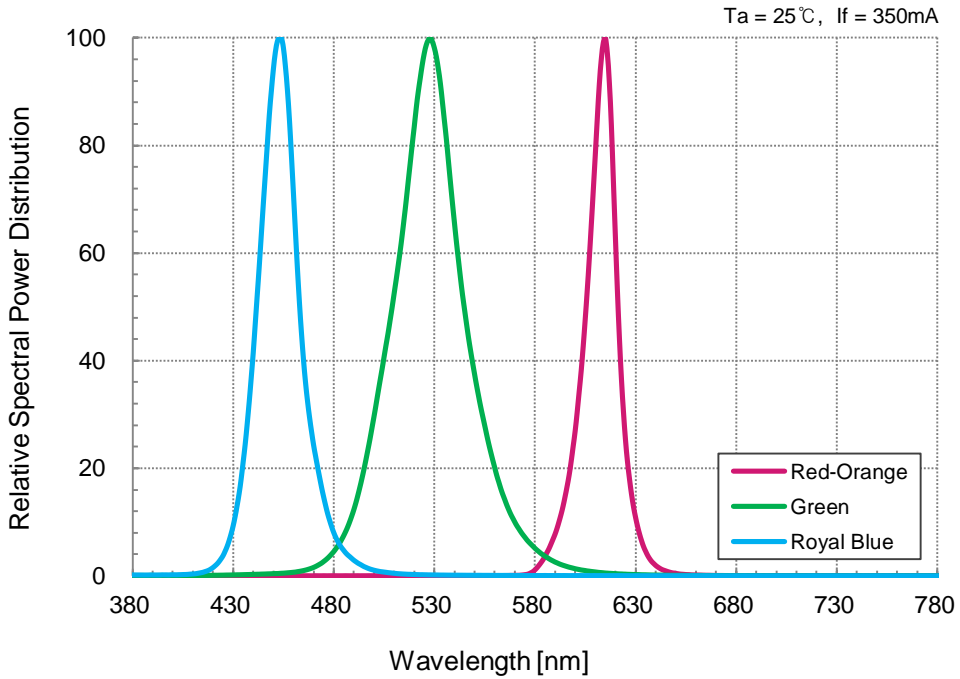

- Dominant Wavelength vs. Forward Current

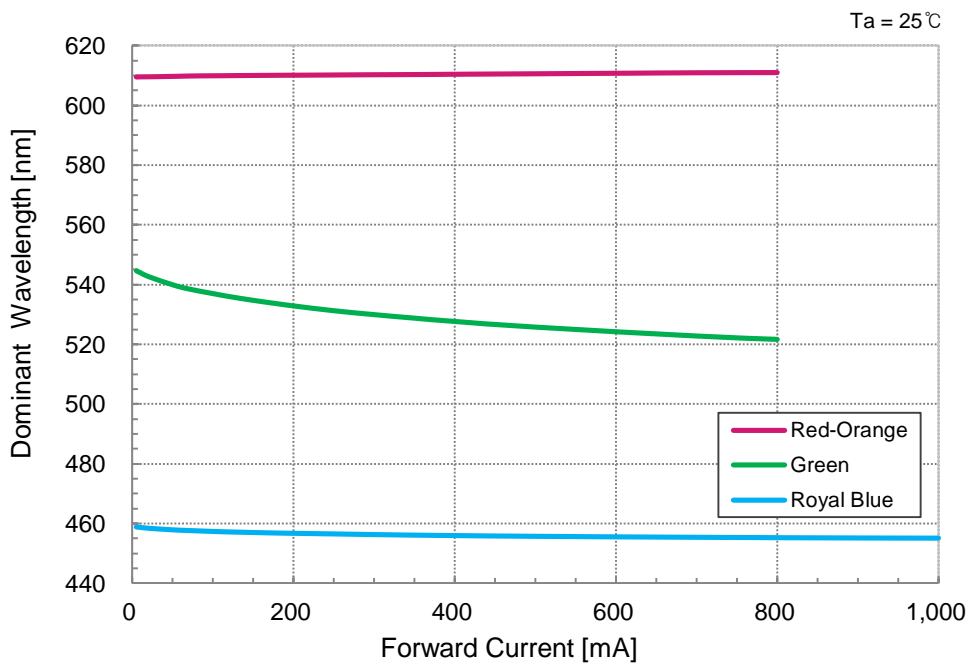

7. Typical Characteristic Curves

- Radiation Characteristics (Red-Orange / Red / Hyper-Red)

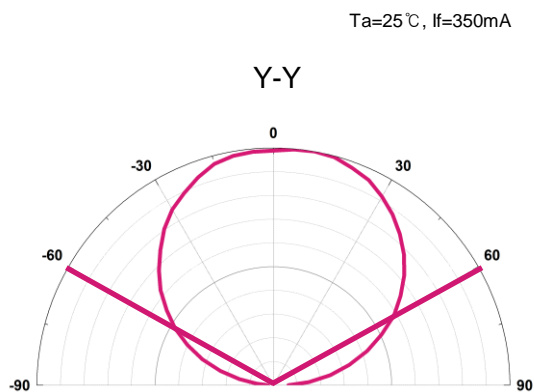
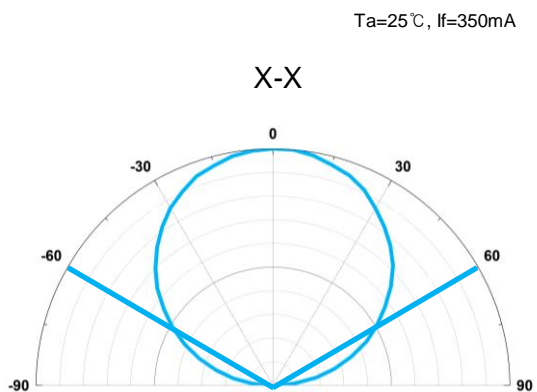

- Radiation Characteristics (Green)

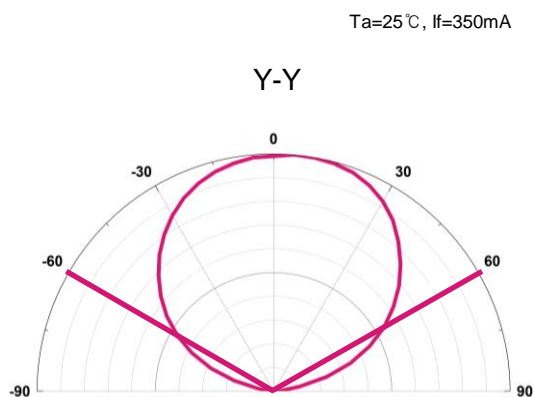
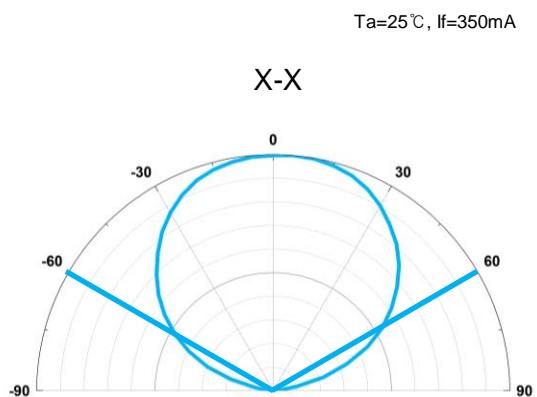

- Radiation Characteristics (Royal Blue / Blue)

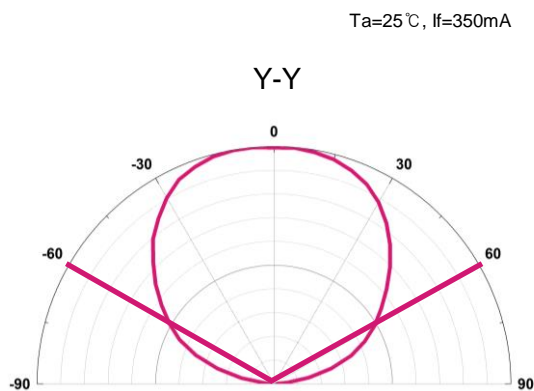
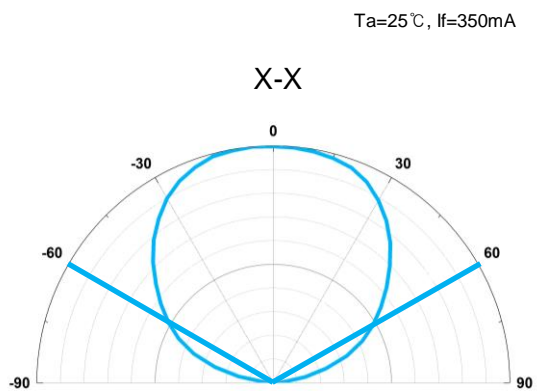

7. Typical Characteristic Curves

- Relative Luminous Flux vs. Temperature

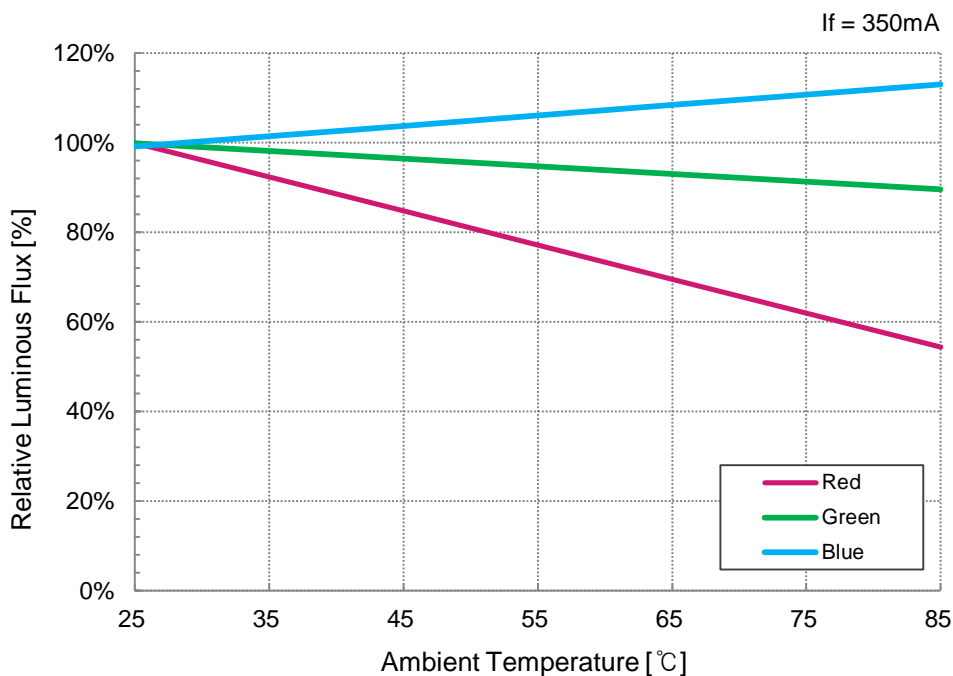

- Relative Forward Voltage vs. Temperature

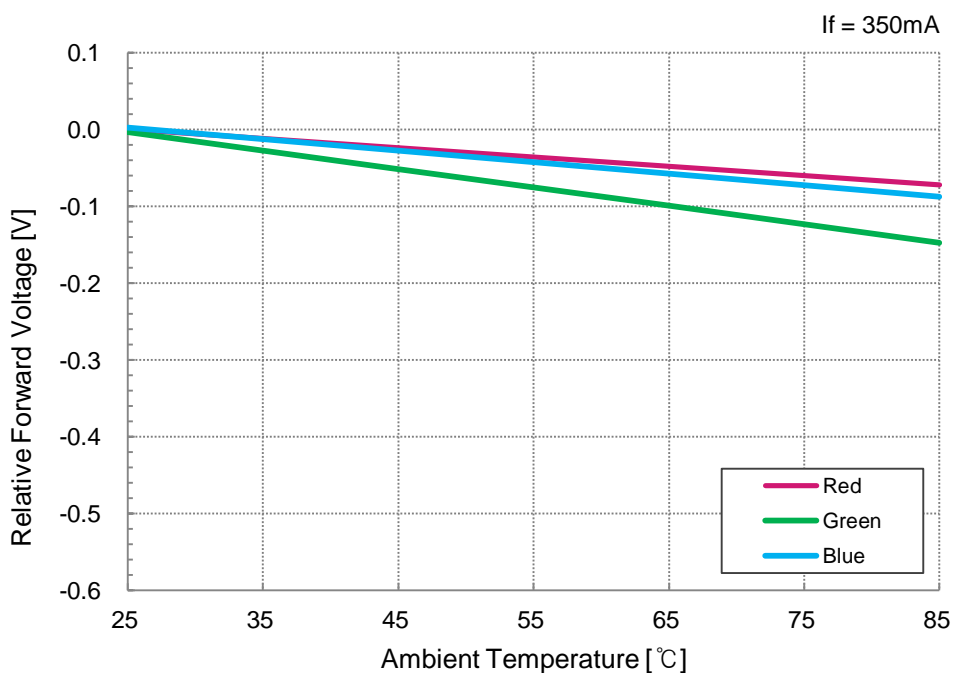

7. Typical Characteristic Curves

- Dominant Wavelength vs. Temperature

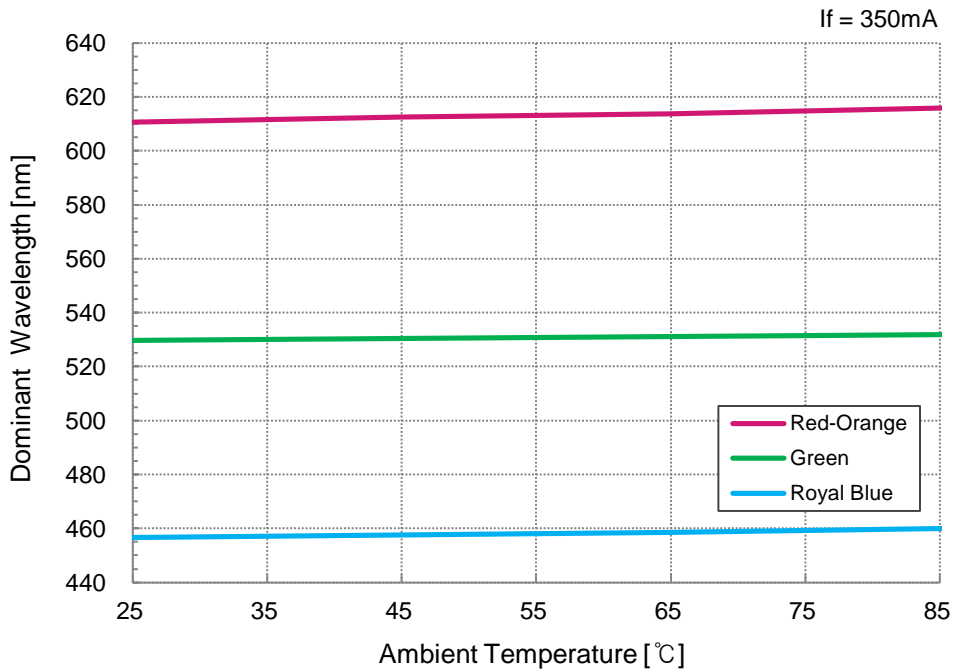

- Derating Curve (Red)

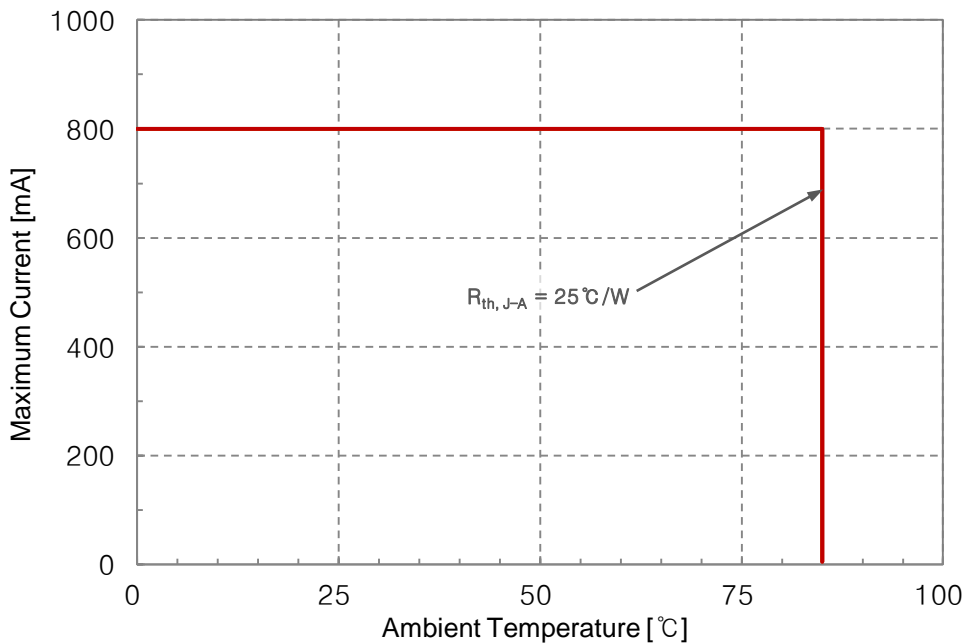

7. Typical Characteristic Curves

- Derating Curve (Green)

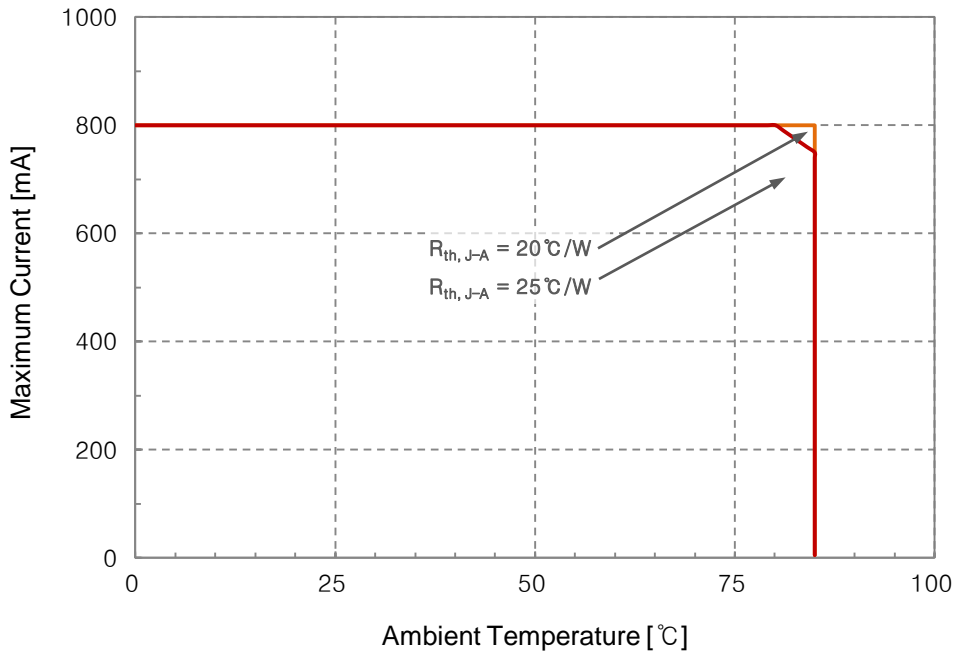

- Derating Curve (Blue)

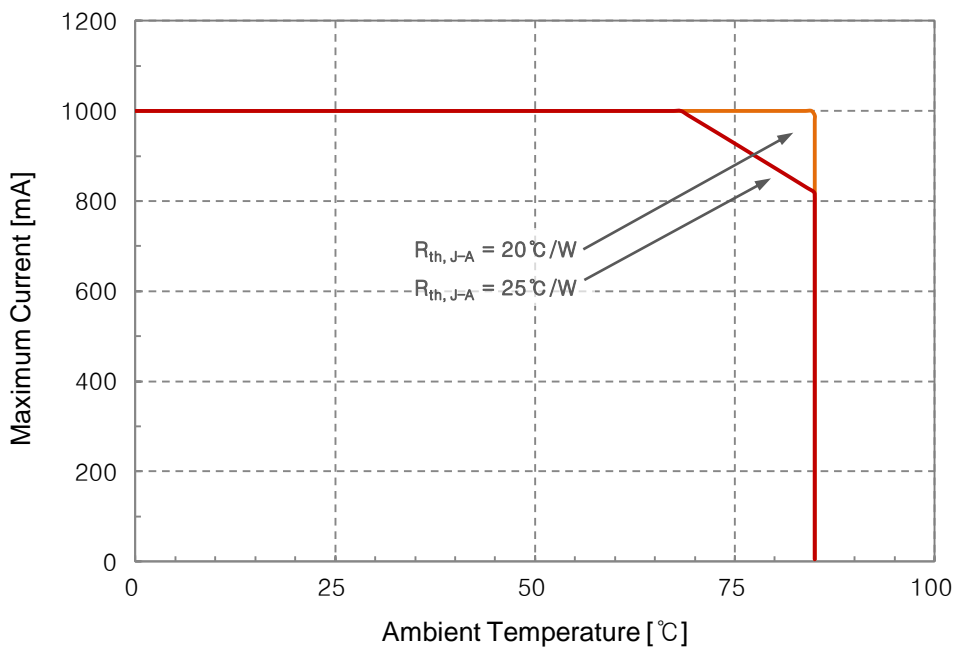

8. Reliability Test Items and Conditions

8-1. Failure Criteria

Items	Symbol	Test Conditions	Criteria	
			Min.	Max.
Forward Voltage	V _f	I _f = 350mA	-	Initial Value × 1.1
Luminous Flux	Φ _v	I _f = 350mA	Initial Value × 0.7	-

8-2. Reliability Tests

No		Items	Test Conditions	Test Hours /Cycles	Sample Size	Ac/Re
1	Red-Orange / Red	Room Temperature Operating Life (RTOL)	T _a = 25°C, I _f = 800mA	1,000 Hours	11 pcs	0/1
2		Wet High Temperature Operating Life (WHTOL)	T _a = 85°C, RH = 85% I _f = 450mA	500 Hours	11 pcs	0/1
3		High Temperature Operating Life (HTOL)	T _a = 85°C, I _f = 450mA	1,000 Hours	11 pcs	0/1
4		Low Temperature Operating Life (LTOL)	T _a = -40°C, I _f = 450mA	1,000 Hours	11 pcs	0/1
1	Green	Room Temperature Operating Life (RTOL)	T _a = 25°C, I _f = 800mA	1,000 Hours	11 pcs	0/1
2		Wet High Temperature Operating Life (WHTOL)	T _a = 85°C, RH = 85% I _f = 700mA	500 Hours	11 pcs	0/1
3		High Temperature Operating Life (HTOL)	T _a = 85°C, I _f = 700mA	1,000 Hours	11 pcs	0/1
4		Low Temperature Operating Life (LTOL)	T _a = -40°C, I _f = 700mA	1,000 Hours	11 pcs	0/1
1	Royal Blue	Room Temperature Operating Life (RTOL)	T _a = 25°C, I _f = 1000mA	1,000 Hours	11 pcs	0/1
2		Wet High Temperature Operating Life (WHTOL)	T _a = 85°C, RH = 85% I _f = 800mA	500 Hours	11 pcs	0/1
3		High Temperature Operating Life (HTOL)	T _a = 85°C, I _f = 800mA	1,000 Hours	11 pcs	0/1
4		Low Temperature Operating Life (LTOL)	T _a = -40°C, I _f = 800mA	1,000 Hours	11 pcs	0/1

8. Reliability Test Items and Conditions

8-3. Reliability Tests

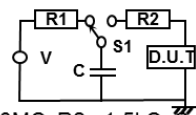
No	Items	Test Conditions	Test Hours /Cycles	Sample Size	Ac/Re
5	High Temperature Storage Life (HTSL)	Ta = 100°C	1,000 Hours	11 pcs	0/1
6	Low Temperature Storage Life (LTSL)	Ta = -40°C	1,000 Hours	11 pcs	0/1
7	Wet High Temperature Storage Life (WHTSL)	Ta = 85°C, RH = 85%	1,000 Hours	11 pcs	0/1
8	Temperature Cycle (TC)	-40°C (30min) ~ 100°C (30min)	100 Cycles	11 pcs	0/1
9	Moisture Sensitivity Level (MSL)	Tsld = 260°C (Pre treatment 60°C, 60% 168 hours)	3 Times	11 pcs	0/1
10	Electrostatic Discharge Test Voltage 8kV (HBM)	 <p>R1 : 10MΩ, R2 : 1.5kΩ, C : 100pF</p>	3 Times	11 pcs	0/1
11	Vibration	100~2000~100Hz Sweep 4min. 200m/s ² , 3 directions	48 Minutes	11 pcs	0/1

- ※ All samples are tested using LG Innotek Standard Metal PCB (25x25x1.6 mm³(L×W×H)) except MSL test .
- ※ All samples must pass each test item and all test items must be satisfied.

9. Packing and Labeling of Products

9-1. Taping Outline Dimensions

Reel

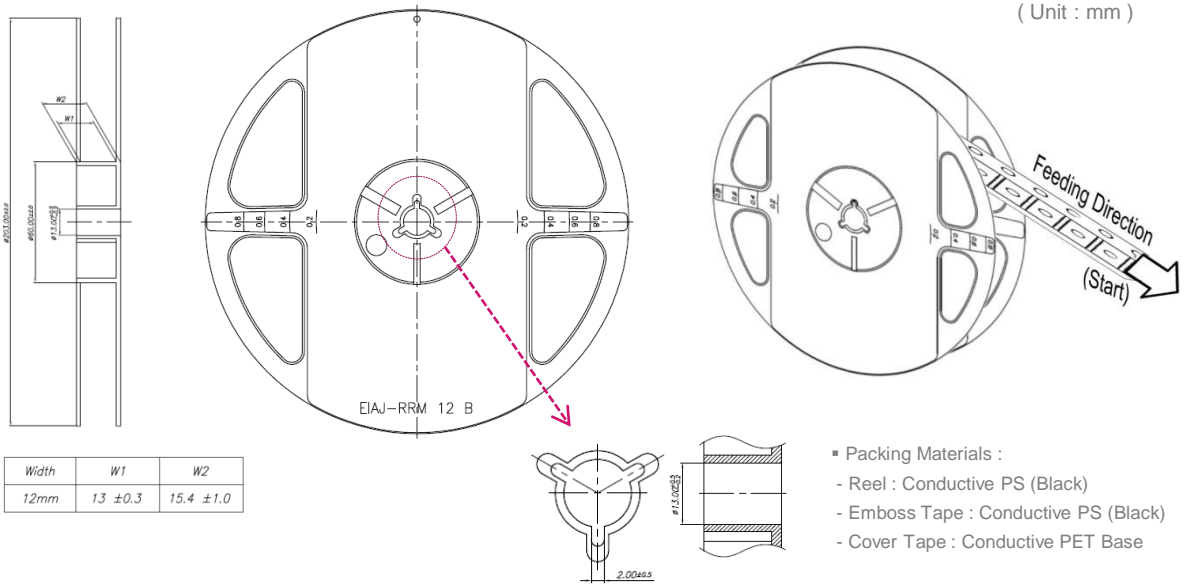

Tape

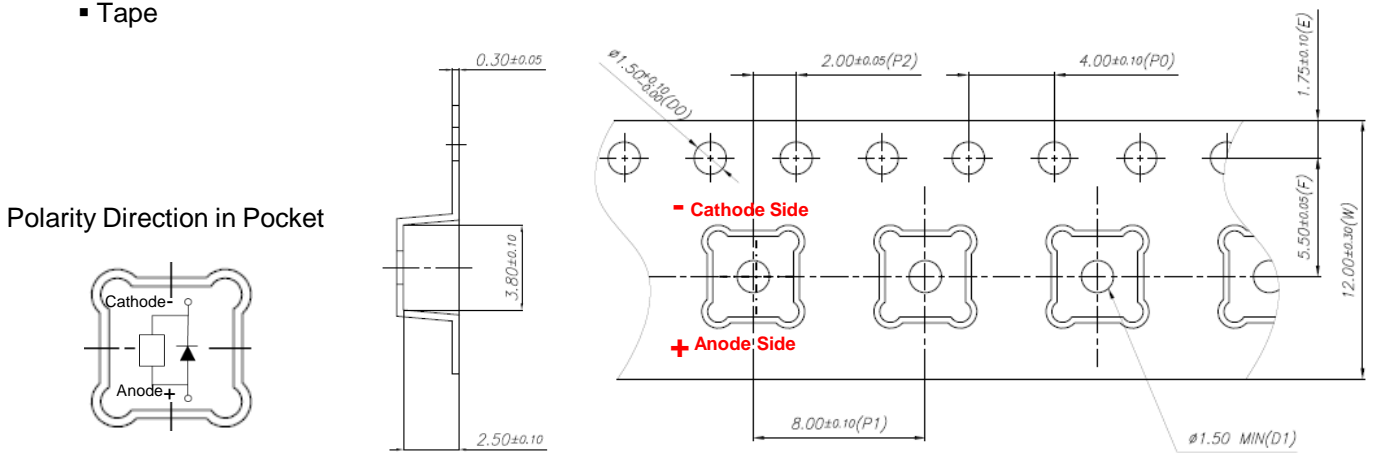

Taping Arrangement

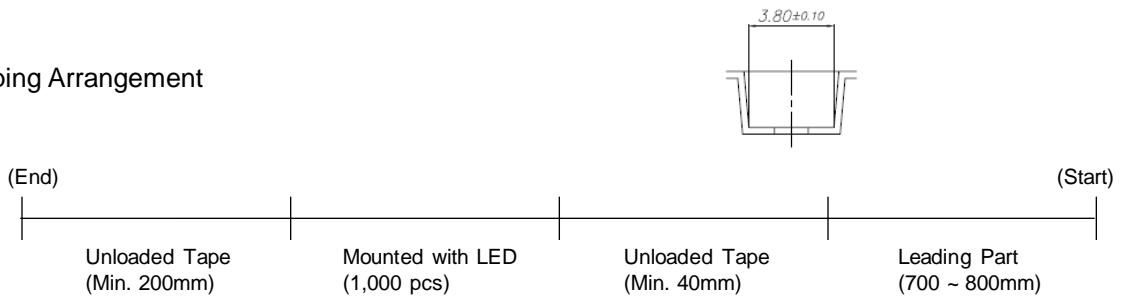

9. Packing and Labeling of Products

9-2. Label Structure

※. Label A

Specifying 'Lot ID', 'Model Name', 'MES ID', 'RANK', 'Q'ty', 'Run No'

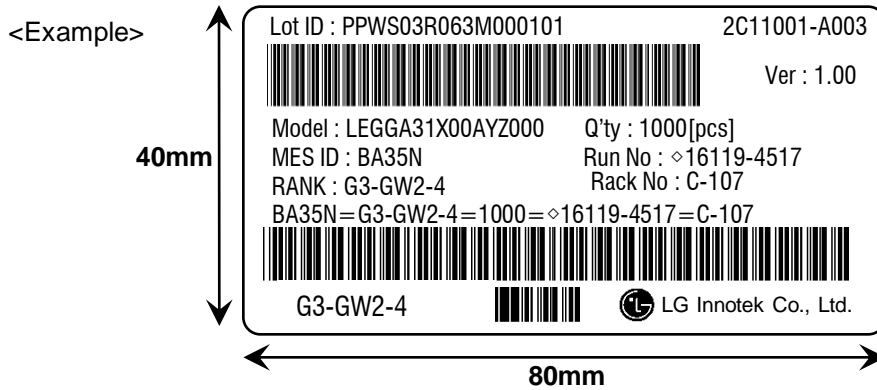

▪ Run No. indication

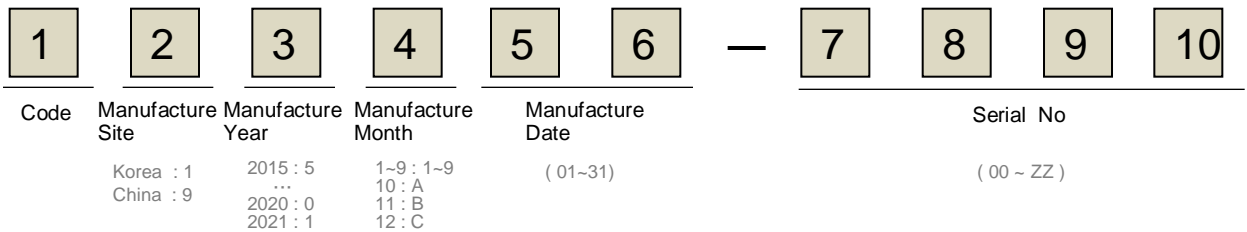

9. Packing and Labeling of Products

9-2. Label Structure

※. Label C

Specifying 'Customer', 'Date', 'Model Name', 'Quantity', 'Customer Part no', 'Outbox ID', 'LGIT Internal Model Name'

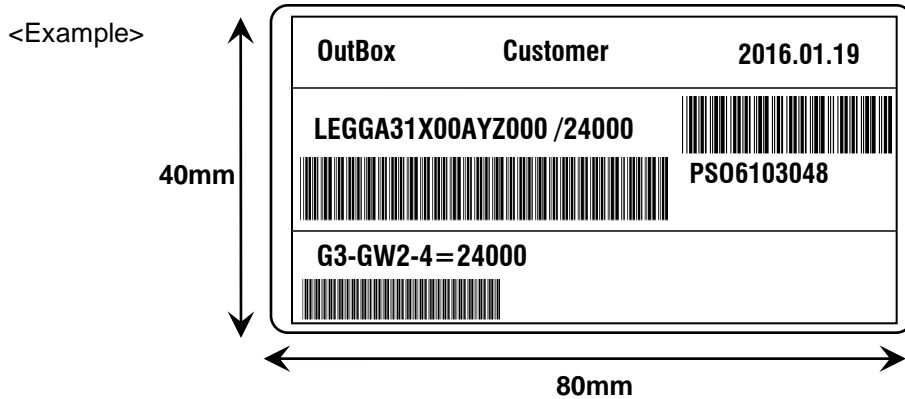

▪ Box ID. indication

1	2	3	4	5	6	7	8	9	10
Manufacture Site	PKG Site	Box	Year	Month	Date		Serial No		
			2015 : 5 ... 2020 : 0 2021 : 1	1~9 : 1~9 10 : A 11 : B 12 : C	(01 ~ 31)		(001 ~ 999)		
Paju : P Huizhou : H	PKG : S, P	Inner Box : I Outer Box : O							

9. Packing and Labeling of Products

9-3. Packing Structures

Reeled products (Numbers of products are Max. 1,000 pcs) packed in a sealed-off and moisture-proof aluminum bag with desiccants (Silica Gel). Maximum four aluminum bags are packed in an inner box and six inner boxes are packed in an outer box. (Total Max. number of products are 24,000 pcs)

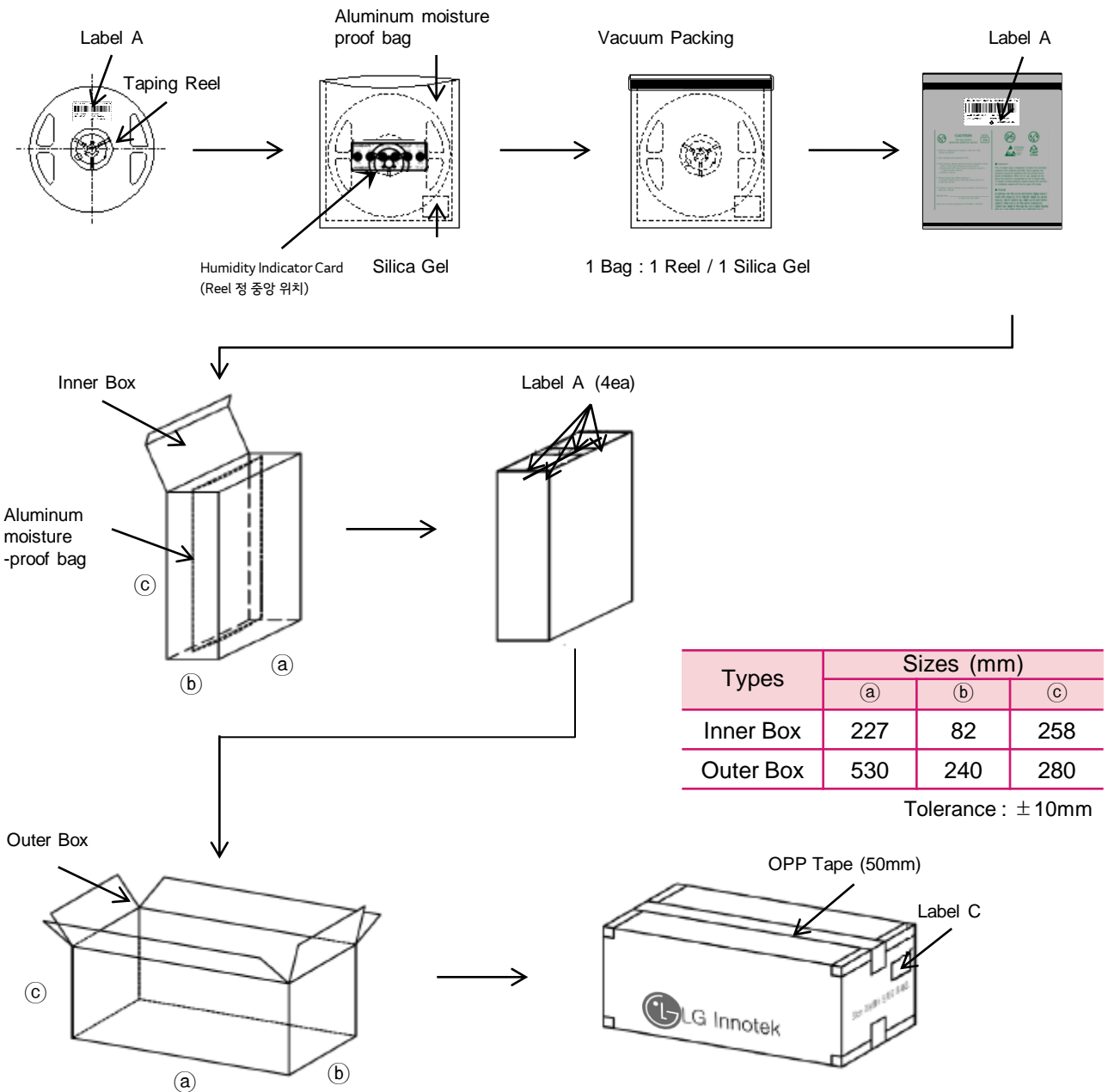

10. Cautions on Use

10-1. Moisture-Proof Package

- The moisture in the SMD package may vaporize and expand during soldering.
- The moisture can damage the optical characteristics of the LEDs due to the encapsulation.

10-2. During Storage

Conditions		Temperature	Humidity	Time
Storage	Before Opening Aluminum Bag	5°C ~ 30°C	< 50%RH	Within 1 Year from the Delivery Date
	After Opening Aluminum Bag	5°C ~ 30°C	< 60%RH	≤ 672 hours
Baking		65 ± 5°C	< 10%RH	10 ~ 24 hours

- The LEDs should be stored in a clean environment. If the LEDs are stored for 3 months or more after being shipped from LGIT, a sealed container with a nitrogen gas should be used for storage.
- When storing the LEDs after opening aluminum bag, reseal with a moisture absorbent material inside

10-3. During Usage

- The LED should be avoided direct contact with hazardous materials such as sulfur, chlorine, phthalate, acid, solvent, etc. These materials(S, Cl, VOCs, etc) may cause sulfurization of silver lead-frame or encapsulant silicone discoloration in LED.
 VOCs(Volatile Organic Compounds) can be generated from adhesives glue, cleaning flux, molding hardener or organic additive which used in luminaires fixtures and they(VOCs) may cause a significant lumen degradation of LED in luminaires when they exposed to heat or light.
 To prevent this phenomenon, materials used in luminaires must be carefully selected by users.
- The metal parts on the LED can rust when exposed to corrosive gases. Therefore, exposure to corrosive gases must be avoided during operation and storage.
- The metal parts also can be affected not only by the corrosive gases emitted inside of the end-products but by the gases penetrated from outside environment.
- Extreme environments such as sudden ambient temperature changes or high humidity that can cause condensation must be avoided.

10-4. Cleaning

- Do not use brushes for cleaning or organic solvents (i.e. Acetone, TCE, etc..) for washing as they may damage the resin of the LEDs.
- Isopropyl Alcohol(IPA) is the recommended solvent for cleaning the LEDs under the following conditions. Cleaning Condition : IPA, 25°C max. × 60sec max.
- Ultrasonic cleaning is not recommended. Pretests should be conducted with the actual cleaning process to validate that the process will not damage the LEDs.

10. Cautions on Use

10-5. Thermal Management

- The thermal design of the end product must be seriously considered, particularly at the beginning of the system design process.
- The generation of heat is greatly impacted by the input power, the thermal resistance of the circuit boards and the density of the LED array combined with other components.

10-6. Static Electricity

- Wristbands and anti-electrostatic gloves are strongly recommended and all devices, equipment and machinery must be properly grounded when handling the LEDs, which are sensitive against static electricity and surge.
- Precautions are to be taken against surge voltage to the equipment that mounts the LEDs.
- Unusual characteristics such as significant increase of current leakage, decrease of turn-on voltage, or non-operation at a low current can occur when the LED is damaged.

10-7. Recommended Circuit

- The current through each LED must not exceed the absolute maximum rating when designing the circuits.
- In general, there can be various forward voltages for LEDs. Different forward voltages in parallel via a single resistor can result in different forward currents to each LED, which also can output different luminous flux values. In the worst case, the currents can exceed the absolute maximum ratings which can stress the LEDs. Matrix circuit with a single resistor for each LED is recommended to avoid the luminous flux fluctuations.

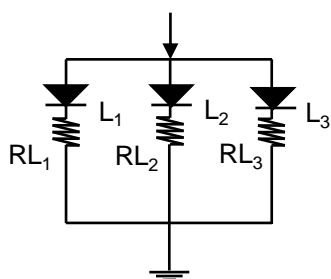

Fig.1 Recommended Circuit in Parallel Mode
: Separate resistors must be used for each LED.

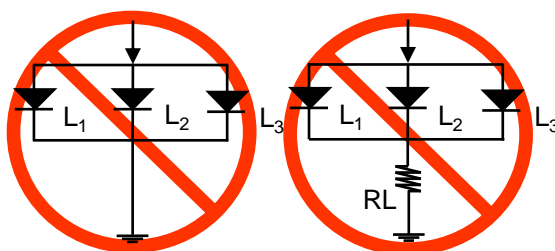

Fig.2 Abnormal Circuit
Circuits to Avoid : The current through the LEDs may vary due to the variation in LED forward voltage.

- The driving circuits must be designed to operate the LEDs by forward bias only.
- Reverse voltages can damage the zener diode, which can cause the LED to fail.
- A constant current LED driver is recommended to power the LEDs.

10. Cautions on Use

10-8. Soldering Conditions

- Reflow soldering is the recommended method for assembling LEDs on a circuit board.
- LG Innotek does not guarantee the performance of the LEDs assembled by the dip soldering method.
- Recommended Soldering Profile (according to JEDEC J-STD-020D)

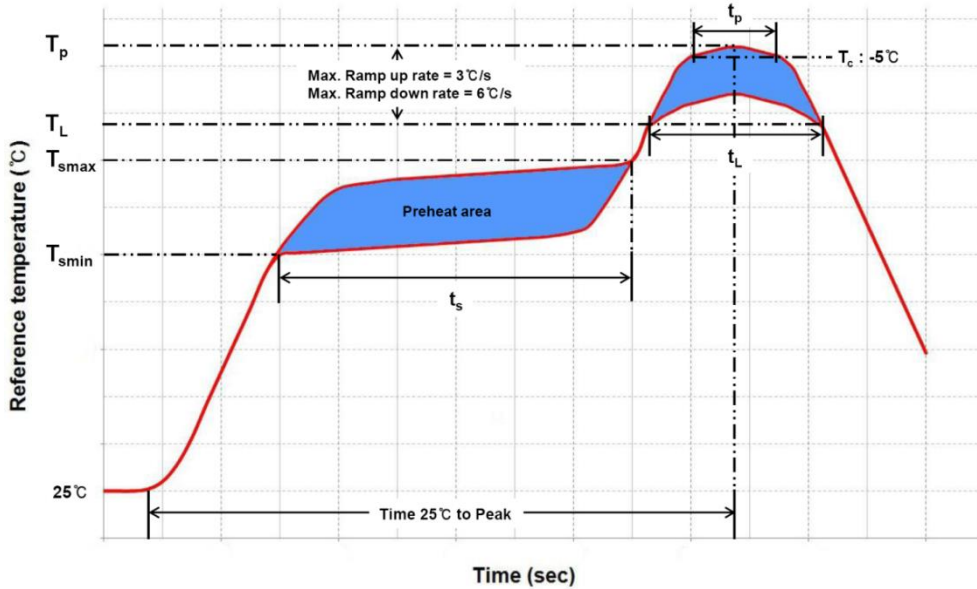

Profile Feature	Pb-Free Assembly	Pb-Based Assembly
Preheat / Soak		
Temperature Min (T_{smin})	150°C	100°C
Temperature Max (T_{smax})	200°C	150°C
Maximum time(t_s) from T_{smin} to T_{smax}	60~120 seconds	60~120 seconds
Ramp-up rate (T_L to T_p)	3°C/ second max.	3°C/ second max.
Liquidus temperature (T_L)	217°C	183°C
Time (t_L) maintained above T_L	60~150 seconds	60~150 seconds
Maximum peak package body temperature (T_p)	260°C	235°C
Time(t_p) within 5°C of the specified temperature (T_c)	30 seconds	20 seconds
Ramp-down rate (T_p to T_L)	6°C/second max.	6°C/second max.
Maximum Time 25°C to peak temperature	8 minutes max.	6 minutes max.

- Reflow or hand soldering at the lowest possible temperature is desirable for the LEDs although the recommended soldering conditions are specified in the above diagrams.
- A rapid cooling process is not recommended for the LEDs from the peak temperature.
- The silicone encapsulant at the top of the LED package is a soft surface, which can easily be damaged by pressure. Precautions should be taken to avoid strong pressure on the silicone resin when leveraging the pick and place machines.
- Reflow soldering should not be done more than two times.

10. Cautions on Use

10-9. Soldering Iron

- The recommended condition is less than 5 seconds at 260°C.
- The time must be shorter for higher temperatures. (+10°C → -1sec).
- The power dissipation of the soldering iron should be lower than 15W and the surface temperature of the device should be controlled at or under 230°C.

10-10. Eye Safety Guidelines

- Do not directly look at the light when the LEDs are on.
- Proceed with caution to avoid the risk of damage to the eyes when examining the LEDs with optical instruments.

10-11. Manual Handling

- Use Teflon-type tweezers to grab the base of the LED and do not apply mechanical pressure on the surface of the encapsulant.

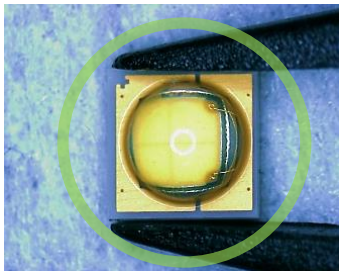

11. Disclaimers

- LG Innotek is not responsible for any damages or accidents caused if the operating or storage conditions exceed the absolute maximum ratings recommended in this document.
- The LEDs described in this document are intended to be operated by ordinary electronic equipment.
- The LEDs should not be used at any lighting products together with the other LEDs, which has a different part number. If required, please contact any sales person.
- It is recommended to consult with LG Innotek when the environment or the LED operation is non-standard in order to avoid any possible malfunctions or damage to product or risk of life or health.
- Disassembly of the LED products for the purpose of reverse engineering is prohibited without prior written consent from LG Innotek. All defected LEDs must be reported to LG Innotek and are not to be disassembled or analyzed.
- The product information can be modified and upgraded without prior notice.

12. Package Nomenclature

All LEDs are tested and sorted by color, luminous flux and forward voltage where every LED in a tube has only a single color bin, luminous flux bin and forward voltage bin. However, the forward voltage bin information is not captured in the part number nomenclature.

A 16-digit part number is required when orders are placed. LG Innotek leverages the following part number nomenclature.

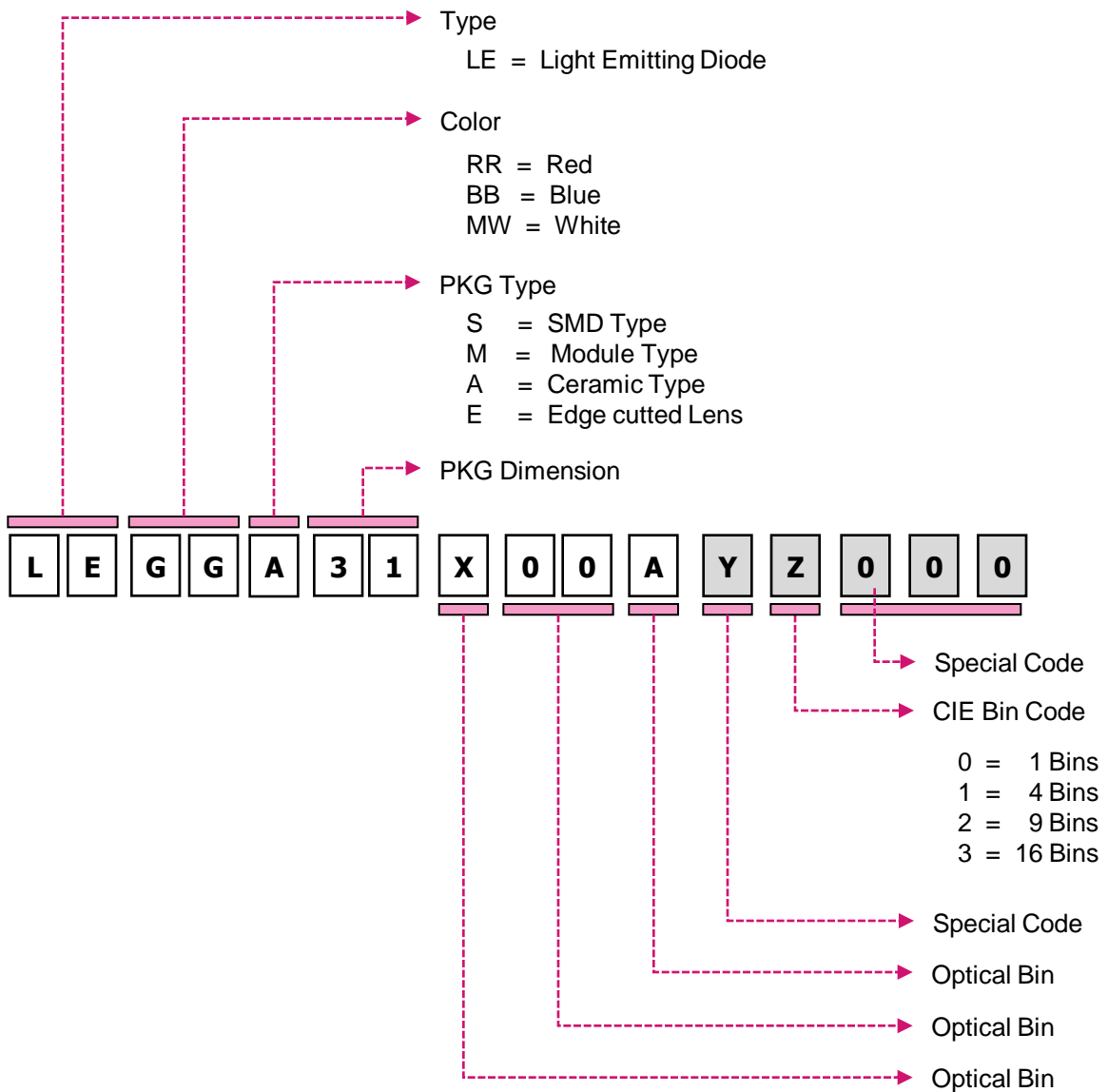

SPECIFICATION			
MODEL	LERRN31W00AYZ000 LEGGA31X00AYZ000 LEBBA31Q00AYZ000	DOCUMENT No.	
REG. DATE	16.10.17	REV. No.	C.0
REV. DATE		PAGE	

Change History of Revision

Revision	Date	Contents of Revision Change	Remark
A	16.08.26	New Establishment	
B	16.09.30	Vf Bin is Changed	
C	16.10.17	A Label is Changed	
D	17.01.12	Wavelength Variety	