

## RF (CD287H)

### Features

- Long life of 3000-6000 hours at 105°C .
- High frequency, low impedance, high ripple current.
- Especially designed for LED driver.
- RoHS Compliant.

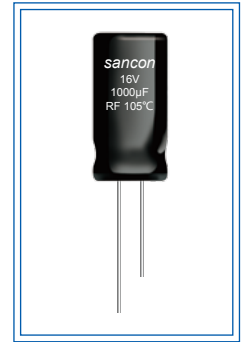

### Specifications

Item	Performance Characteristics																											
Operating Temperature Range	-40~+105°C																											
Rated Voltage Range	6.3~100V																											
Nominal Capacitance Range	22~6800µF																											
Capacitance Tolerance	±20%(+20°C ,120Hz)																											
Leakage Current	$I \leq 0.01CV$ or $3\mu A$ ( after 2 minutes , Whichever is greater )																											
Dissipation Factor ( $tg\delta$ , +20°C ,120Hz )	<table border="1"> <tr> <td><math>U_R(V)</math></td> <td>6.3</td> <td>10</td> <td>16</td> <td>25</td> <td>35</td> <td>50</td> <td>63</td> <td>100</td> </tr> <tr> <td><math>tg\delta</math></td> <td>0.22</td> <td>0.19</td> <td>0.16</td> <td>0.14</td> <td>0.12</td> <td>0.10</td> <td>0.09</td> <td>0.08</td> </tr> </table>	$U_R(V)$	6.3	10	16	25	35	50	63	100	$tg\delta$	0.22	0.19	0.16	0.14	0.12	0.10	0.09	0.08									
	$U_R(V)$	6.3	10	16	25	35	50	63	100																			
$tg\delta$	0.22	0.19	0.16	0.14	0.12	0.10	0.09	0.08																				
When rated capacitance is over 1000µF, $tg\delta$ shall be added 0.02 to the listed value with increase of every 1000µF.																												
Temperature Characteristics (Impedance ratio at 120Hz)	<table border="1"> <tr> <td><math>U_R(V)</math></td> <td>6.3</td> <td>10</td> <td>16</td> <td>25</td> <td>35</td> <td>40</td> <td>63</td> <td>100</td> </tr> <tr> <td>Z-25°C /+20°C</td> <td>4</td> <td>3</td> <td>2</td> <td>2</td> <td>2</td> <td>2</td> <td>2</td> <td>2</td> </tr> <tr> <td>Z-40°C /+20°C</td> <td>8</td> <td>6</td> <td>4</td> <td>3</td> <td>3</td> <td>3</td> <td>3</td> <td>3</td> </tr> </table>	$U_R(V)$	6.3	10	16	25	35	40	63	100	Z-25°C /+20°C	4	3	2	2	2	2	2	2	Z-40°C /+20°C	8	6	4	3	3	3	3	3
	$U_R(V)$	6.3	10	16	25	35	40	63	100																			
	Z-25°C /+20°C	4	3	2	2	2	2	2	2																			
Z-40°C /+20°C	8	6	4	3	3	3	3	3																				
Load Life	After applying rated voltage with specified ripple current for specified time at +105°C and then resumed 24hours: Capacitance change : ±25% of the initial measured value Leakage current : ≤ the initial specified value Dissipation factor: ≤ 200% of the initial specified value																											
	<table border="1"> <tr> <th>Case Size</th> <th>Life Time(hrs)</th> </tr> <tr> <td><math>\Phi D \leq 6.3</math></td> <td>3000</td> </tr> <tr> <td><math>\Phi D = 8</math></td> <td>4000</td> </tr> <tr> <td><math>\Phi D = 10</math></td> <td>5000</td> </tr> <tr> <td><math>\Phi D \geq 12.5</math></td> <td>6000</td> </tr> </table>	Case Size	Life Time(hrs)	$\Phi D \leq 6.3$	3000	$\Phi D = 8$	4000	$\Phi D = 10$	5000	$\Phi D \geq 12.5$	6000																	
Case Size	Life Time(hrs)																											
$\Phi D \leq 6.3$	3000																											
$\Phi D = 8$	4000																											
$\Phi D = 10$	5000																											
$\Phi D \geq 12.5$	6000																											
Shelf Life	After storage for 1000 hours at +105°C , and then resumed 24 hours: Capacitance change : ±25% of the initial measured value Leakage current : ≤ 200% of the initial specified value Dissipation factor: ≤ 200% of the initial specified value																											

LED & Low Impedance

### Diagram of Dimensions

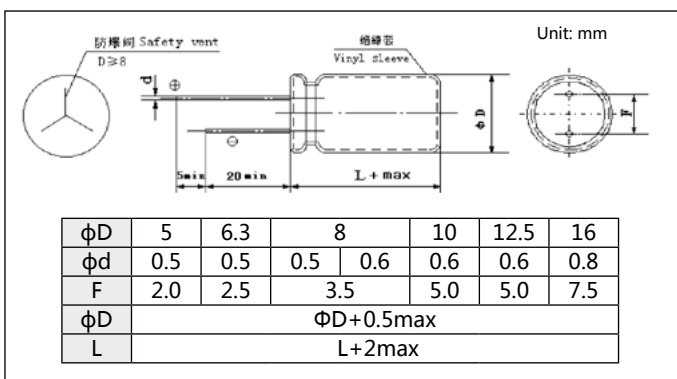

### Multiplier for Ripple Current

Frequency coefficient		Frequency(Hz)			
Coefficient	22~180µF	0.40	0.75	0.90	1.00
	220~560µF	0.50	0.85	0.94	1.00
	680~1800µF	0.60	0.87	0.95	1.00
	2200~3900µF	0.75	0.90	0.95	1.00
	4700~6800µF	0.85	0.95	0.98	1.00
Temperature coefficient					
Temperature( °C )		+70	+85	+105	
coefficient		1.96	1.68	1.0	

Standard Size

Rated Voltage (V <sub>dc</sub> )	Capacitance (μF)	Size ΦD×L (mm)	Rated ripple current (mA <sub>rms</sub> ) 105°C/100KHz	Impedance (Ω MAX)	
				20°C, 100KHz	-10°C, 100KHz
6.3 (0J)	150	5×11	210	0.58	2.3
	330	6.3×11	340	0.22	0.87
	680	8×11.5	640	0.13	0.52
	820	10×12.5	865	0.080	0.32
	1000	8×16	840	0.087	0.35
	1200	8×20	1050	0.069	0.27
	1200	10×16	1210	0.060	0.24
	1500	10×20	1400	0.046	0.18
	1800	12.5×16	1450	0.049	0.16
	2200	10×23	1650	0.042	0.17
	2700	10×28	1910	0.031	0.12
	2700	16×16	1940	0.042	0.12
	3300	12.5×20	1900	0.035	0.12
	3900	12.5×25	2230	0.027	0.089
	3900	18×16	2210	0.043	0.11
	4700	12.5×30	2650	0.024	0.078
	5600	12.5×35	2880	0.020	0.065
	5600	16×20	2530	0.027	0.078
	6800	12.5×40	3350	0.017	0.056
	6800	16×25	2930	0.021	0.060
6800	18×20	2860	0.026	0.067	
8200	16×31.5	3450	0.017	0.050	
10000	16×35.5	3610	0.015	0.044	
10000	18×25	3140	0.019	0.049	
12000	16×40	4080	0.013	0.038	
12000	18×31.5	4170	0.015	0.040	
15000	18×35.5	4220	0.014	0.038	
18000	18×40	4280	0.012	0.032	
10 (1A)	100	5×11	210	0.58	2.3
	220	6.3×11	340	0.22	0.87
	470	8×11.5	640	0.13	0.52
	680	8×16	840	0.087	0.35
	680	10×12.5	865	0.080	0.32
	1000	8×20	1050	0.069	0.27
	1000	10×16	1210	0.060	0.24
	1200	10×20	1400	0.046	0.18
	1500	10×23	1650	0.042	0.17
	1500	12.5×16	1450	0.049	0.16
	2200	10×28	1910	0.031	0.12
	2200	12.5×20	1900	0.035	0.12
	2200	16×16	1940	0.042	0.12
	2700	18×16	2210	0.043	0.11
	3300	12.5×25	2230	0.027	0.089
	3900	12.5×30	2650	0.024	0.078
	3900	16×20	2530	0.027	0.078
	4700	12.5×35	2880	0.020	0.065
	5600	12.5×40	3350	0.017	0.056
	5600	16×25	2930	0.021	0.060
5600	18×20	2860	0.026	0.067	
6800	16×31.5	3450	0.017	0.050	
6800	18×25	3140	0.019	0.049	
8200	16×35.5	3610	0.015	0.044	
8200	18×31.5	4170	0.015	0.040	
10000	16×40	4080	0.013	0.038	
10000	18×35.5	4220	0.014	0.038	
12000	18×40	4280	0.012	0.032	

Rated Voltage (V <sub>dc</sub> )	Capacitance (μF)	Size ΦD×L (mm)	Rated ripple current (mA <sub>rms</sub> ) 105°C/100KHz	Impedance (Ω MAX)	
				20°C, 100KHz	-10°C, 100KHz
16 (1C)	56	5×11	210	0.58	2.3
	120	6.3×11	340	0.22	0.87
	330	8×11.5	640	0.13	0.52
	470	8×16	840	0.087	0.35
	470	10×12.5	865	0.080	0.32
	680	8×20	1050	0.069	0.27
	680	10×16	1210	0.060	0.24
	1000	10×20	1400	0.046	0.18
	1000	12.5×16	1450	0.049	0.16
	1200	10×23	1650	0.042	0.17
	1500	10×28	1910	0.031	0.12
	1500	12.5×20	1900	0.035	0.12
	1500	16×16	1940	0.042	0.12
	2200	12.5×25	2230	0.027	0.089
	2200	18×16	2210	0.043	0.11
	2700	12.5×30	2650	0.024	0.078
	2700	16×20	2530	0.027	0.078
	3300	12.5×35	2880	0.020	0.065
	3900	12.5×40	3350	0.017	0.056
	3900	16×25	2930	0.021	0.060
3900	18×20	2860	0.026	0.067	
4700	16×31.5	3450	0.017	0.050	
4700	18×25	3140	0.019	0.049	
5600	16×35.5	3610	0.015	0.044	
5600	18×31.5	4170	0.015	0.040	
6800	16×40	4080	0.013	0.038	
8200	18×35.5	4220	0.014	0.038	
10000	18×40	4280	0.012	0.032	
25 (1E)	47	5×11	210	0.58	2.3
	100	6.3×11	340	0.22	0.87
	220	8×11.5	640	0.13	0.52
	330	8×16	840	0.087	0.35
	330	10×12.5	865	0.080	0.32
	470	8×20	1050	0.069	0.27
	470	10×16	1210	0.060	0.24
	680	10×20	1400	0.046	0.18
	680	12.5×16	1450	0.049	0.16
	820	10×23	1650	0.042	0.17
	1000	10×28	1910	0.031	0.12
	1000	12.5×20	1900	0.035	0.12
	1000	16×16	1940	0.042	0.12
	1200	18×16	2210	0.043	0.11
	1500	12.5×25	2230	0.027	0.089
	1800	12.5×30	2650	0.024	0.078
	1800	16×20	2530	0.027	0.078
	2200	12.5×35	2880	0.020	0.065
	2200	18×20	2860	0.026	0.067
	2700	12.5×40	3350	0.017	0.056
2700	16×25	2930	0.021	0.060	
3300	16×31.5	3450	0.017	0.050	
3300	18×25	3140	0.019	0.049	
3900	16×35.5	3610	0.015	0.044	
3900	18×31.5	4170	0.015	0.040	
4700	16×40	4080	0.013	0.038	
4700	18×35.5	4220	0.014	0.038	
5600	18×40	4280	0.012	0.032	

LED & Low Impedance

Standard Size

Rated Voltage (V <sub>dc</sub> )	Capacitance (μF)	Size ΦD×L (mm)	Rated ripple current (mA <sub>rms</sub> ) 105°C/100KHz	Impedance (Ω MAX)	
				20°C, 100KHz	-10°C, 100KHz
35 (1V)	33	5×11	210	0.58	2.3
	56	6.3×11	340	0.22	0.87
	150	8×11.5	640	0.13	0.52
	220	8×16	840	0.087	0.35
	220	10×12.5	865	0.080	0.32
	270	8×20	1050	0.069	0.27
	330	10×16	1210	0.060	0.24
	470	10×20	1400	0.046	0.18
	470	12.5×16	1450	0.049	0.16
	560	10×23	1650	0.042	0.17
	680	10×28	1910	0.031	0.12
	680	12.5×20	1900	0.035	0.12
	680	16×16	1940	0.042	0.12
	1000	12.5×25	2230	0.027	0.089
	1000	18×16	2210	0.043	0.11
	1200	12.5×30	2650	0.024	0.078
	1200	16×20	2530	0.027	0.078
	1500	12.5×35	2880	0.020	0.065
	1800	12.5×40	3350	0.017	0.056
	1800	16×25	2930	0.021	0.060
1800	18×20	2860	0.026	0.067	
2200	16×31.5	3450	0.017	0.050	
2200	18×25	3140	0.019	0.049	
2700	16×35.5	3610	0.015	0.044	
2700	18×31.5	4170	0.015	0.040	
3300	16×40	4080	0.013	0.038	
3300	18×35.5	4220	0.014	0.038	
3900	18×40	4280	0.012	0.032	
50 (1H)	22	5×11	180	0.70	2.8
	56	6.3×11	295	0.30	1.2
	100	8×11.5	555	0.17	0.68
	120	8×16	730	0.12	0.48
	150	10×12.5	760	0.12	0.48
	180	8×20	910	0.091	0.36
	220	10×16	1050	0.084	0.34
	270	10×20	1220	0.060	0.24
	270	12.5×16	1260	0.061	0.20
	330	10×23	1440	0.055	0.22
	470	10×28	1690	0.043	0.17
	470	12.5×20	1660	0.045	0.15
	470	16×16	1690	0.055	0.17
	560	12.5×25	1950	0.034	0.11
	560	18×16	1930	0.054	0.15
	680	12.5×30	2310	0.030	0.10
	820	12.5×35	2510	0.025	0.083
	820	16×20	2210	0.034	0.10
	1000	12.5×40	2920	0.021	0.069
	1000	16×25	2555	0.025	0.075
	1000	18×20	2490	0.036	0.097
	1200	16×31.5	3010	0.022	0.066
	1200	18×25	2740	0.026	0.070
	1500	16×35.5	3150	0.019	0.057
	1800	16×40	3710	0.016	0.048
	1800	18×31.5	3635	0.021	0.057
	2200	18×35.5	3680	0.017	0.046
2700	18×40	3800	0.014	0.038	

Rated Voltage (V <sub>dc</sub> )	Capacitance (μF)	Size ΦD×L (mm)	Rated ripple current (mA <sub>rms</sub> ) 105°C/100KHz	Impedance (Ω MAX)	
				20°C, 100KHz	-10°C, 100KHz
63 (1J)	15	5×11	55	2.3	9.3
	33	6.3×11	115	1.2	5.0
	56	8×11.5	232	0.63	2.8
	82	8×16	300	0.45	2.1
	82	10×12.5	288	0.43	1.8
	120	8×20	362	0.33	1.6
	120	10×16	357	0.31	1.5
	180	10×20	466	0.21	0.94
	180	12.5×16	466	0.23	1.1
	220	10×23	531	0.20	0.84
	270	10×28	663	0.15	0.71
	270	12.5×20	690	0.16	0.64
	270	16×16	795	0.14	0.66
	330	12.5×25	784	0.12	0.45
	390	18×16	920	0.12	0.50
	470	12.5×30	905	0.10	0.42
	470	16×20	1040	0.091	0.38
	560	12.5×35	1050	0.083	0.35
	560	16×25	1250	0.073	0.27
	680	12.5×40	1180	0.071	0.30
	680	18×20	1240	0.080	0.30
	820	16×31.5	1570	0.054	0.20
	820	18×25	1490	0.057	0.21
	1000	16×35.5	1790	0.045	0.17
	1000	18×31.5	1630	0.047	0.17
	1200	16×40	2020	0.040	0.15
	1200	18×35.5	1790	0.040	0.15
1500	18×40	2330	0.036	0.13	
100 (2A)	6.8	5×11	55	2.3	9.3
	15	6.3×11	115	1.2	5.0
	27	8×11.5	232	0.63	2.8
	39	8×16	300	0.45	2.1
	47	10×12.5	288	0.43	1.8
	56	8×20	362	0.33	1.6
	68	10×16	357	0.31	1.5
	82	10×20	466	0.21	0.94
	82	12.5×16	466	0.23	1.1
	100	10×23	531	0.20	0.84
	120	10×28	663	0.15	0.71
	120	12.5×20	690	0.16	0.64
	150	16×16	795	0.14	0.66
	180	12.5×25	784	0.12	0.45
	180	18×16	920	0.12	0.50
	220	12.5×30	905	0.10	0.42
	220	16×20	1040	0.091	0.38
	270	12.5×35	1050	0.083	0.35
	270	16×25	1250	0.073	0.27
	330	12.5×40	1180	0.071	0.30
	330	18×20	1240	0.080	0.30
	390	16×31.5	1570	0.054	0.20
	390	18×25	1490	0.057	0.21
	470	16×35.5	1790	0.045	0.17
	470	18×31.5	1630	0.047	0.17
	560	16×40	2020	0.040	0.15
	680	18×35.5	1790	0.040	0.15
820	18×40	2330	0.036	0.13	

LED & Low Impedance