

DETAILS

Product Number	F16048_LINNEA-UP
Family	Linnea
Type	Lens
Color	clear
Diameter	285,0 x 40,0 mm
Height	10,30 mm
Style	rectang
Optic Material	PC
Holder Material	
Fastening	clips
Status	production ready
ROHS Compliant	Yes
Date Updated	12/03/2018

OPTICAL PROPERTIES

LED	Viewing Angle	Light Beam	Efficiency	cd/lm	Connector
Tridino 1ft 1100lm xxxHE 1R HV	Asymmetric deg	Wide-Area...	79 %	0.320	-
XP-E	Asymmetric deg	Wide-Area...	76 %	0.300	-
NF2x757G	Asymmetric deg	Wide-Area...	77 %	0.320	-
PrevaLED Linear Slim 3 (1100lm)	Asymmetric deg	Wide-Area...	74 %	0.270	-
PrevaLED Linear Slim 3 (2000lm)	Asymmetric deg	Wide-Area...	74 %	0.270	-
Duris S5 (2 chip)	Asymmetric deg	Wide-Area...	75 %	0.270	-
Duris S5 (Single chip)	Asymmetric deg	Wide-Area...	76 %	0.280	-
Fortimo LED Strip 1ft 1100lm FC HV4 & L	Asymmetric deg	Wide-Area...	73 %	0.250	-
Fortimo LED Strip 1ft 650lm FC HV4 & L	Asymmetric deg	Wide-Area...	73 %	0.240	-
LT-S282H	Asymmetric deg	Wide-Area...	77 %	0.320	-
LT-Q282B	Asymmetric deg	Wide-Area...	77 %	0.310	-
LT-H282C	Asymmetric deg	Wide-Area...	77 %	0.310	-
LT-V282E	Asymmetric deg	Wide-Area...	77 %	0.320	-
SunLike 3030	Asymmetric deg	Wide-Area...	76 %	0.280	-
LLE G4 24x280mm 650lm	Asymmetric deg	Wide-Area...	75 %	0.270	-
LLE G4 24x280mm 2000lm ADV	Asymmetric deg	Wide-Area...	75 %	0.260	-
LLE G4 24x280mm 1250lm	Asymmetric deg	Wide-Area...	75 %	0.270	-



Dimensions measured from outer edge in (Auxiliary view A)

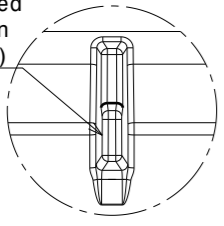

Detail C
Scale: 4:1

Auxiliary view A
Scale: 1:1

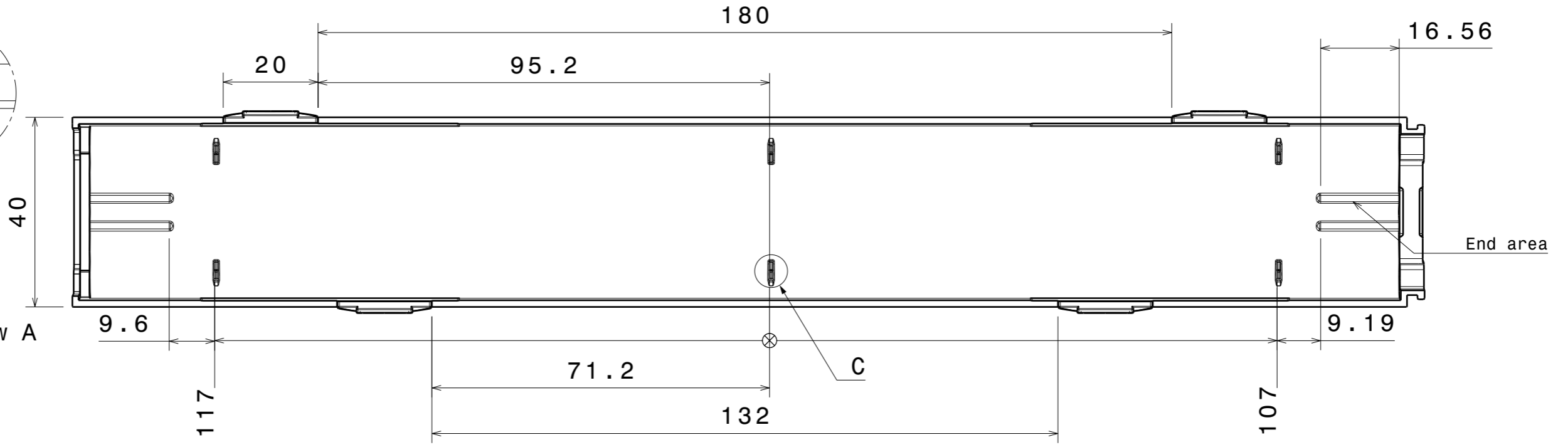

Left view
Scale: 1:1

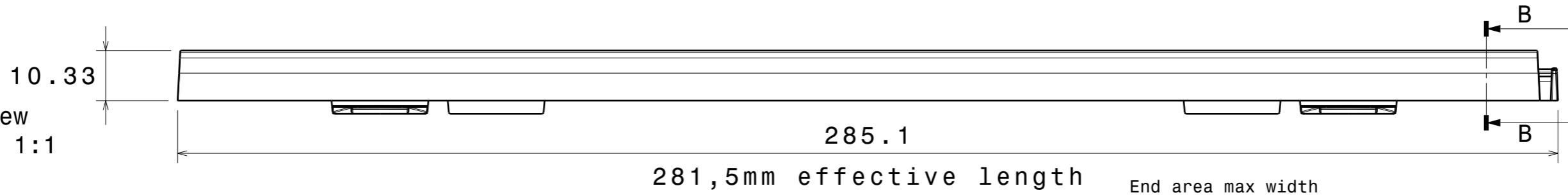

Front view
Scale: 2:1

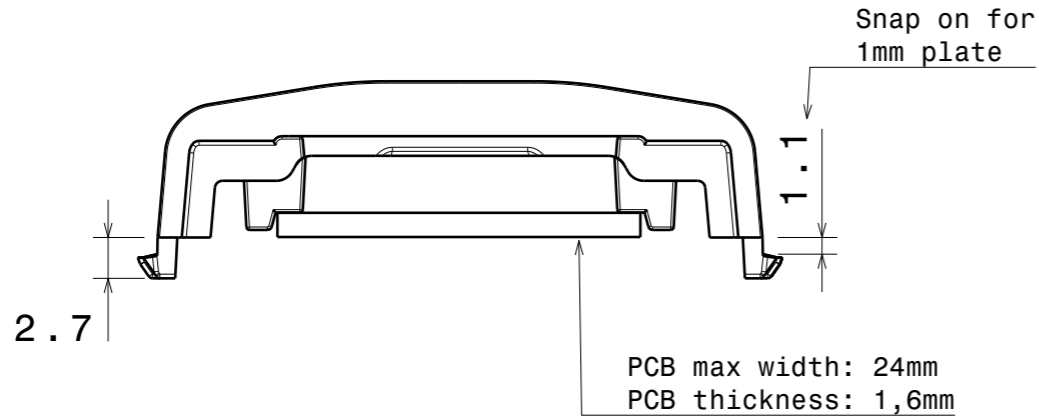

Section view B-B
Scale: 2:1

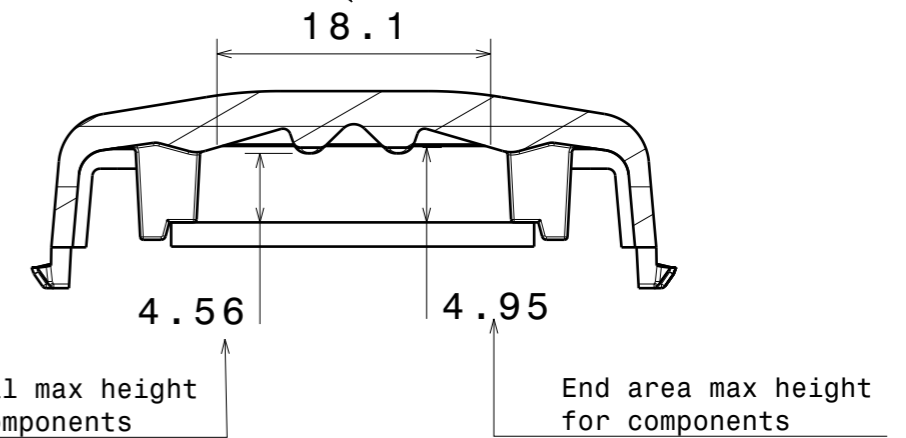

PART NO	MATERIAL
F16048_LINNEA-UP	Polycarbonate

Tolerances if not otherwise shown
According to DIN ISO 2768-1
Linear measures:
Up to 30mm class F, otherwise class M.
According to DIN ISO 2768-2
Form and position: class K
Control for SPC marked dimensions.

LEDiL LediL Oy
Salorankatu 10
FIN 24240 SALO
Finland

First angle projection

DRAWING TITLE
LINNEA-UP Mechanical Drawing

This drawing is the property of LEDiL Oy. It may not be reproduced, copied or communicated without a written agreement with LEDiL Oy.

SIZE	PART NUMBER
A3	F16048

SCALE	WEIGHT	SHEET
1:1	36,13 g	1/2

H G F E D C B A

4

4

3

3

2

2

1

1

H G F E D C B A

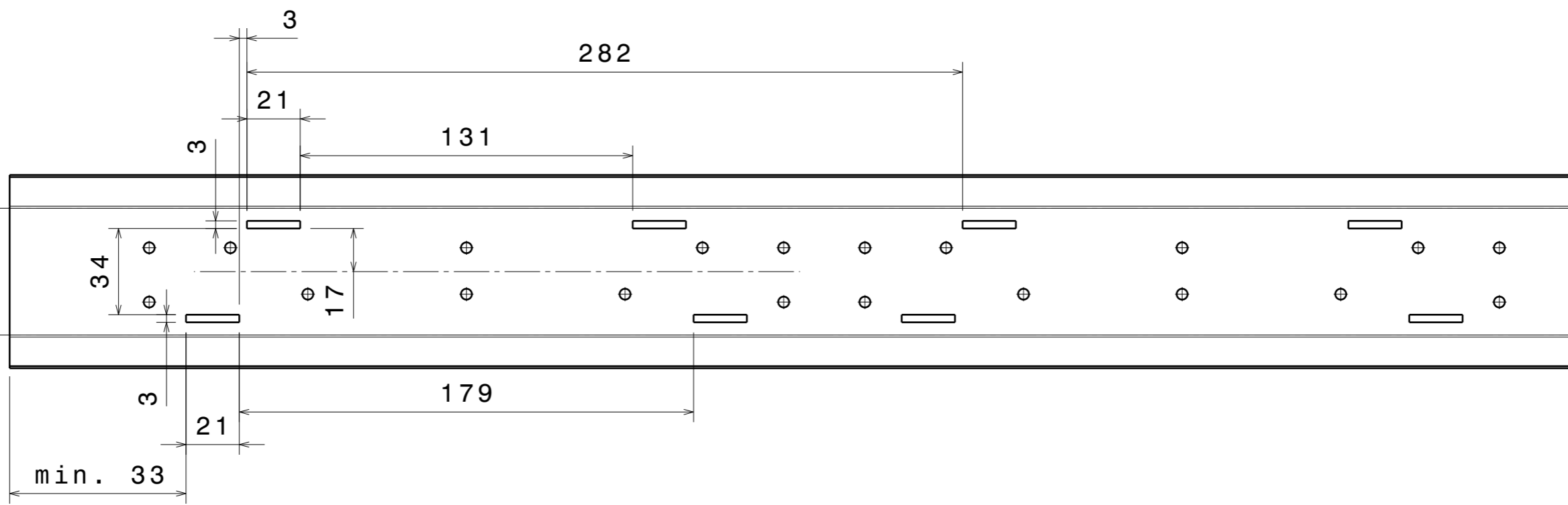

 Ledil Oy Salorankatu 10 FIN 24240 SALO Finland		DRAWING TITLE	
		LINNEA SHEETMETAL CUT OUT	
SIZE	PART NUMBER		
A3	-		
SCALE	1:2	WEIGHT	
		SHEET	2/2

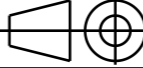
FIRST ANGLE PROJECTION: 

This drawing is the property of LEDiL Oy. It may not be reproduced, copied or communicated without a written agreement with LEDiL Oy.

Luminaire: LEDiL Oy F16048_LINNEA-UP_(Tridino_1ft_1100lm_840HE_1R_HV)
Lamps: 1 x Tridino_1ft_1100lm_840HE_1R_HV_1215.69lm@225mA_P=7.12573W_η=0.225A

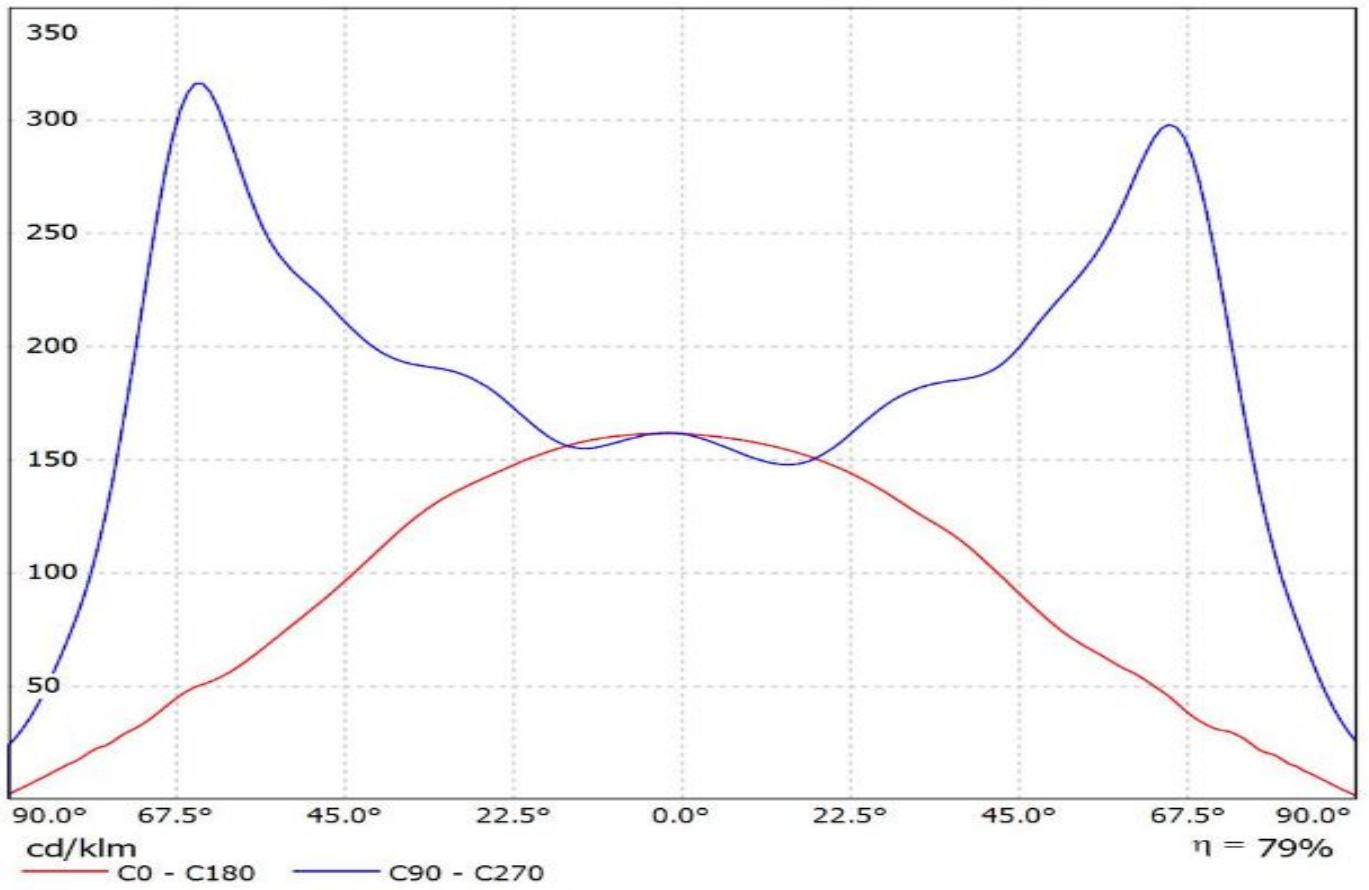

Luminaire: LEDiL Oy F16048_LINNEA-UP_(XP-E)

Lamps: 1 x Cree_XP-E_x12_(XPEWHT-L1-3C0-Q5-0-00)_920.665lm@250mA_P=9.07548W_U=36.329V

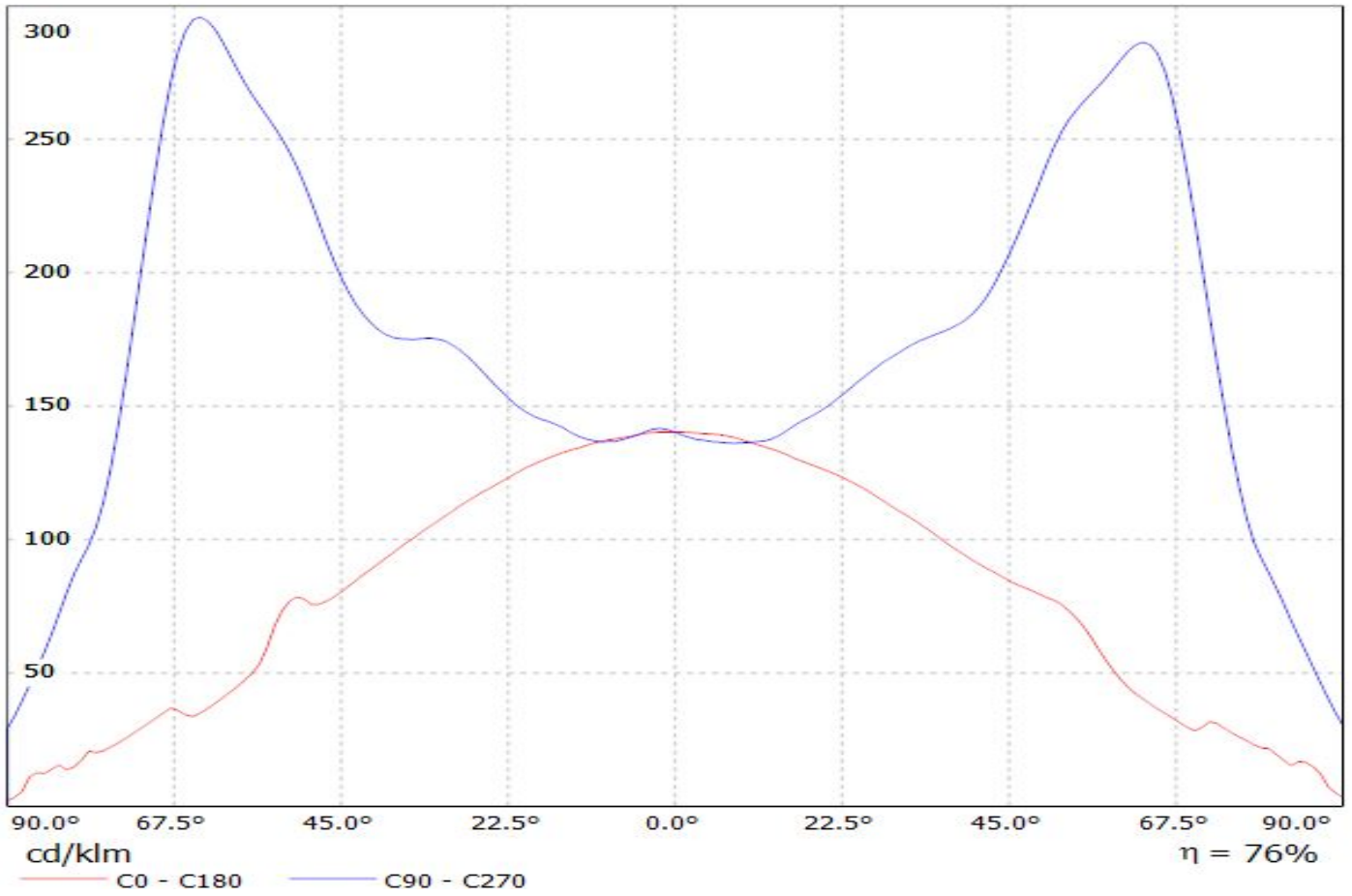

Luminaire: LEDiL Oy F16048_LINNEA-UP_(NF2x757G)

Lamps: 1 x Nichia_NF2x757G_(NF2W757G-F1E)_387.712lm@65mA_P=2.11136W_U=30.422V

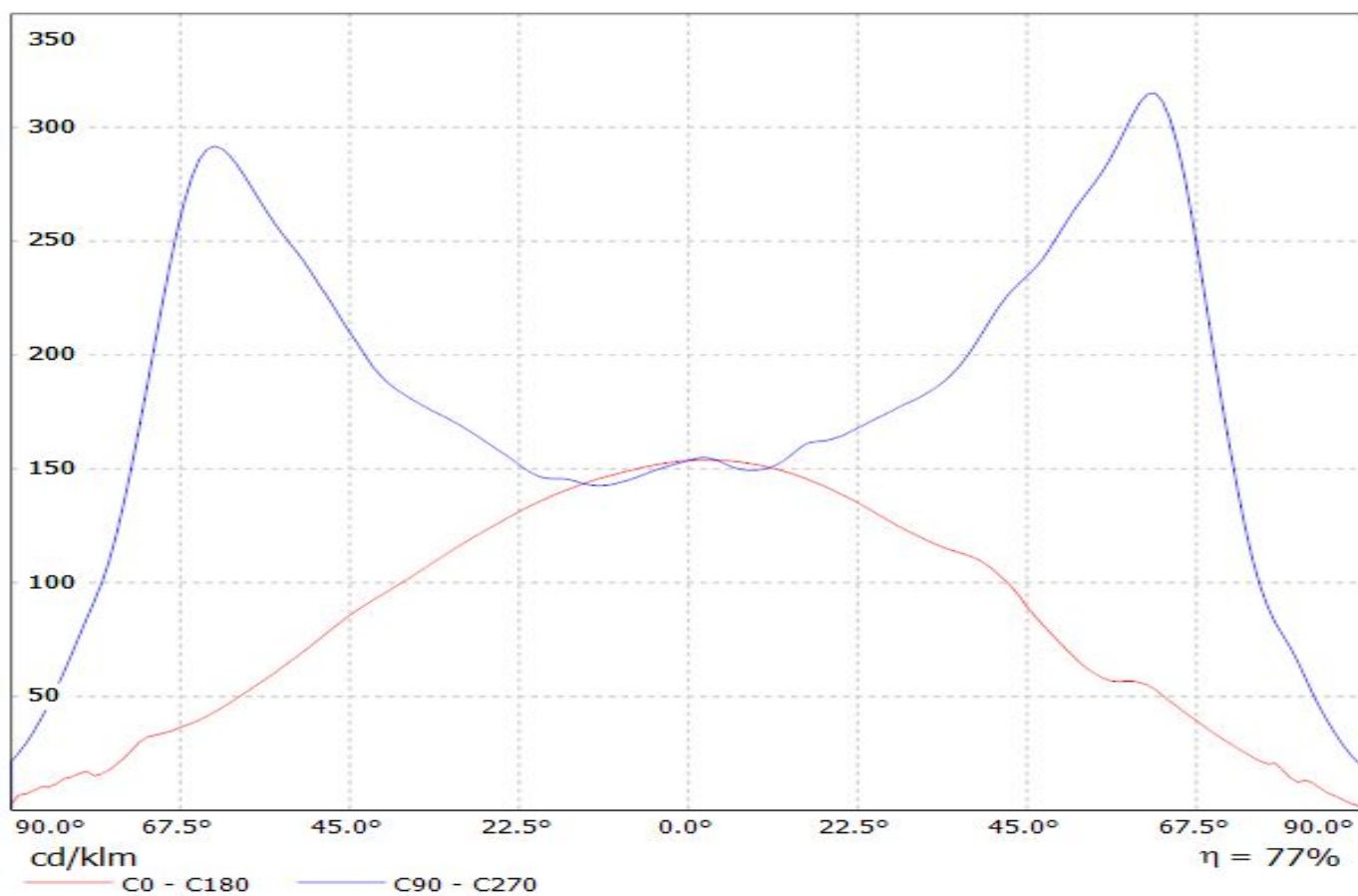

Luminaire: Ledil F16048_LINNEA-UP_(Prevaled_Linear_Slim_1100lm)
Lamps: 1 x Osram_Prevaled_Linear_Slim_1100lm_(PL-LIN S-Z3-1100-8x0-280)
_1029.23lm@175mA_P=6.45102W_U=36.960V

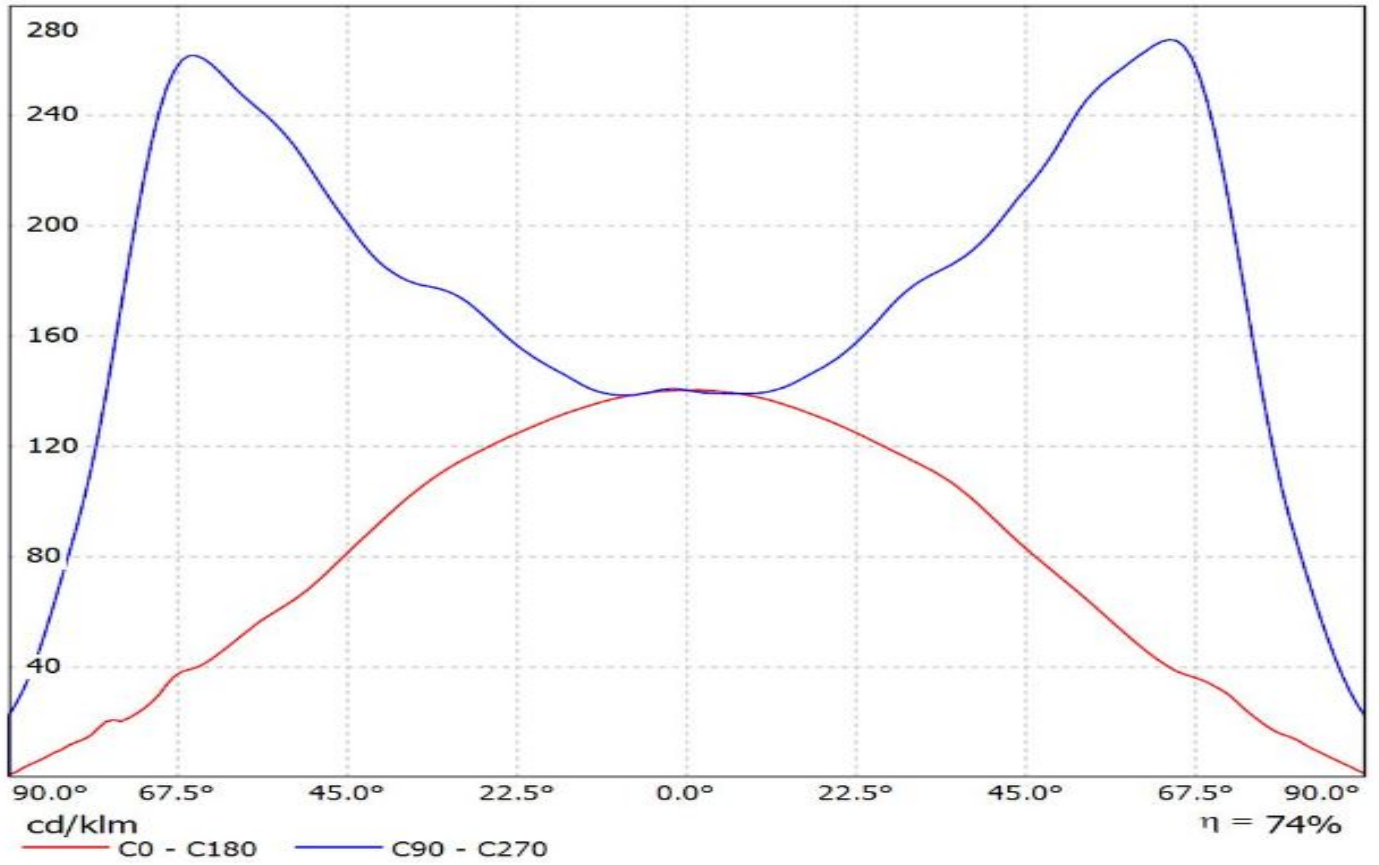

Luminaire: Ledil F16048_LINNEA-UP_(Prevaled_Linear_Slim_3)
Lamps: 1 x Osram_Prevaled_Linear_Slim_3_(PL-LIN S-Z3-2000-840-280)
_1949.14lm@300mA_CCT=4000K_P=12.0015W_U=40.179V

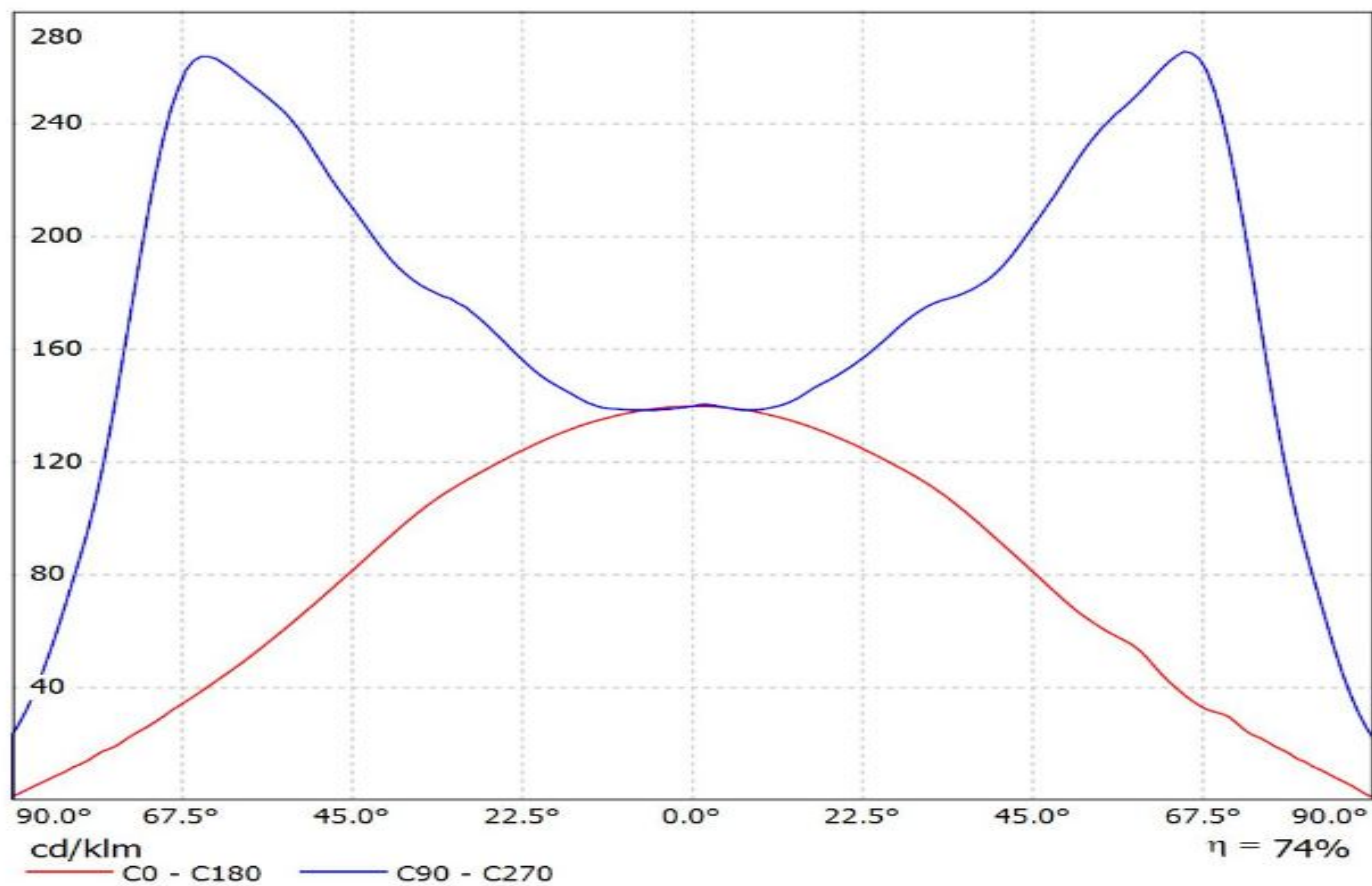

Luminaire: Ledil F16048_LINNEA-UP_(Duris_S5)

Lamps: 1 x Osram_Duris_S5_1183.73lm@250mA_P=8.66003W_U=34.724V

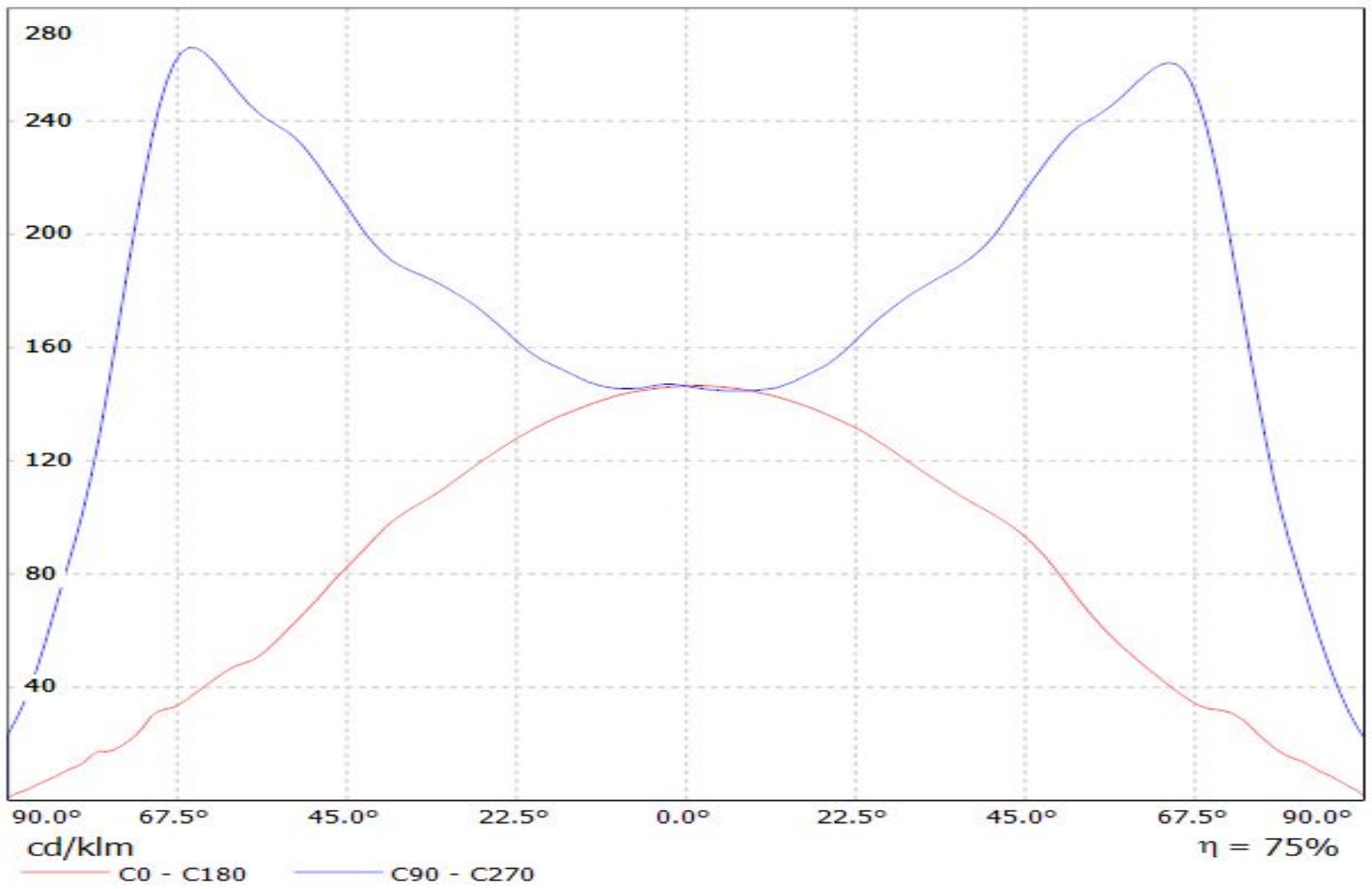

Luminaire: LEDiL Oy F16048_LINNEA-UP_(Duris_S5_1chip)
Lamps: 1 x Osram_Duris_S5_1chip_(GWPSLM31_EM-GUHQ-A535-1)
_359.255lm@65mA_P=2.13817W_U=33.253V

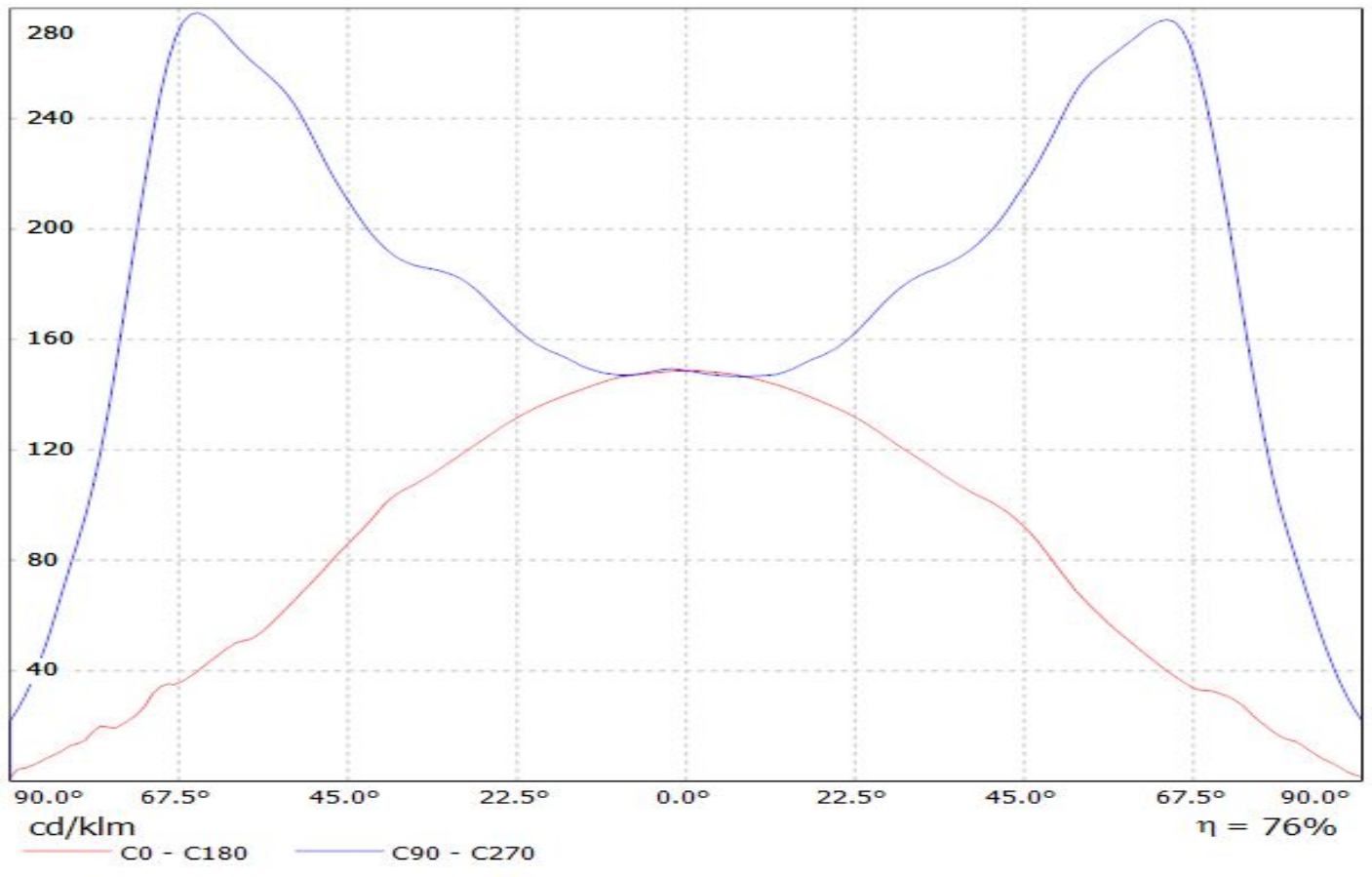

Luminaire: Ledil F16048_LINNEA-UP_(Fortimo_LED_Strip_1ft_1100lm_FC_HV4)
Lamps: 1 x Philips_Fortimo_LED_Strip_1ft_1100lm_930_FC_HV4_735.772lm@250mA_P=5.6145W_U=22.496V

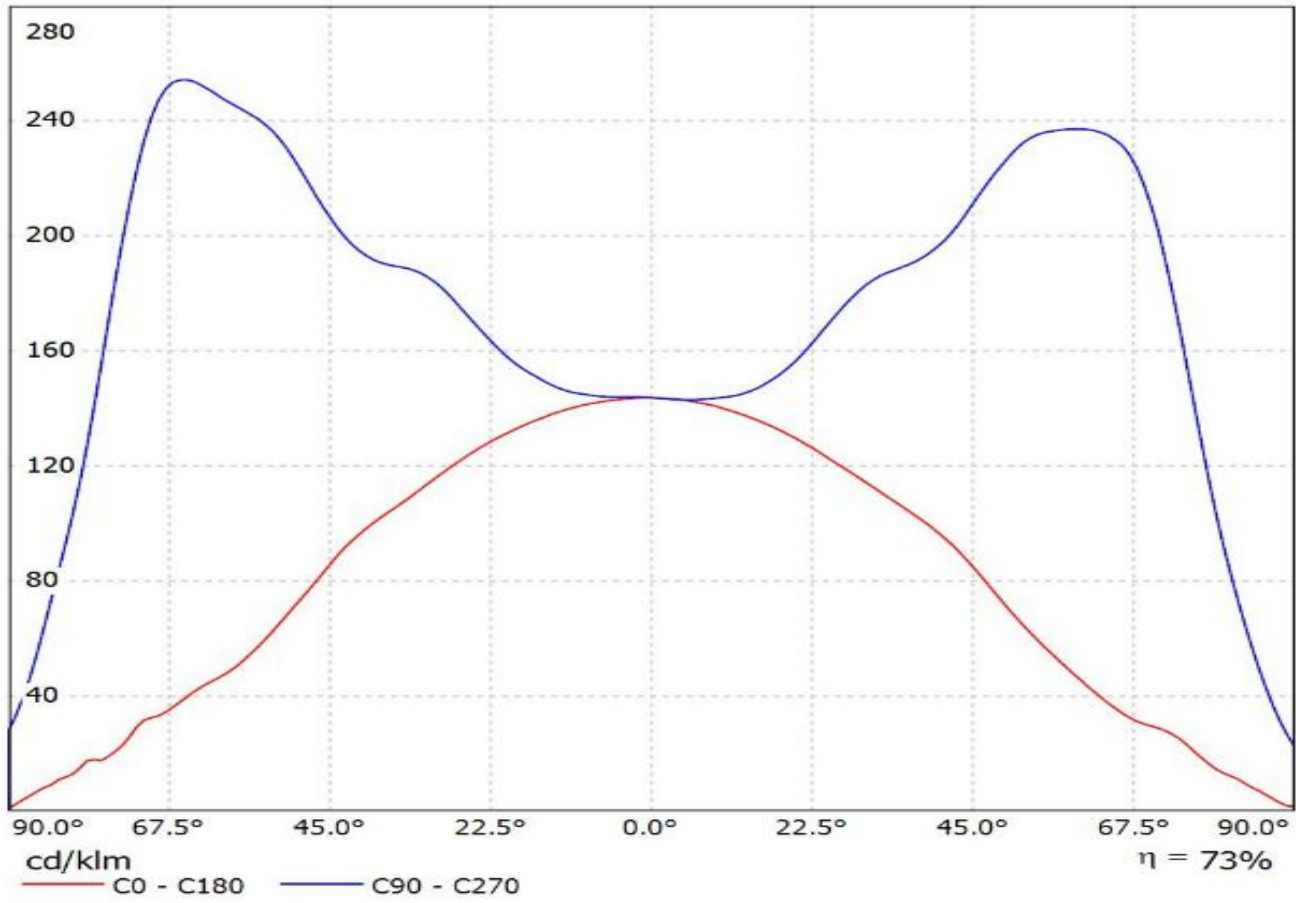

Luminaire: Ledil F16048_LINNEA-UP_(Fortimo_LED_Strip_1ft_650lm_FC_LV4)

Lamps: 1 x Philips_Fortimo_LED_Strip_1ft_650lm_FC_LV4_994.849lm@190mA_P=6.82273W_U=35.990V

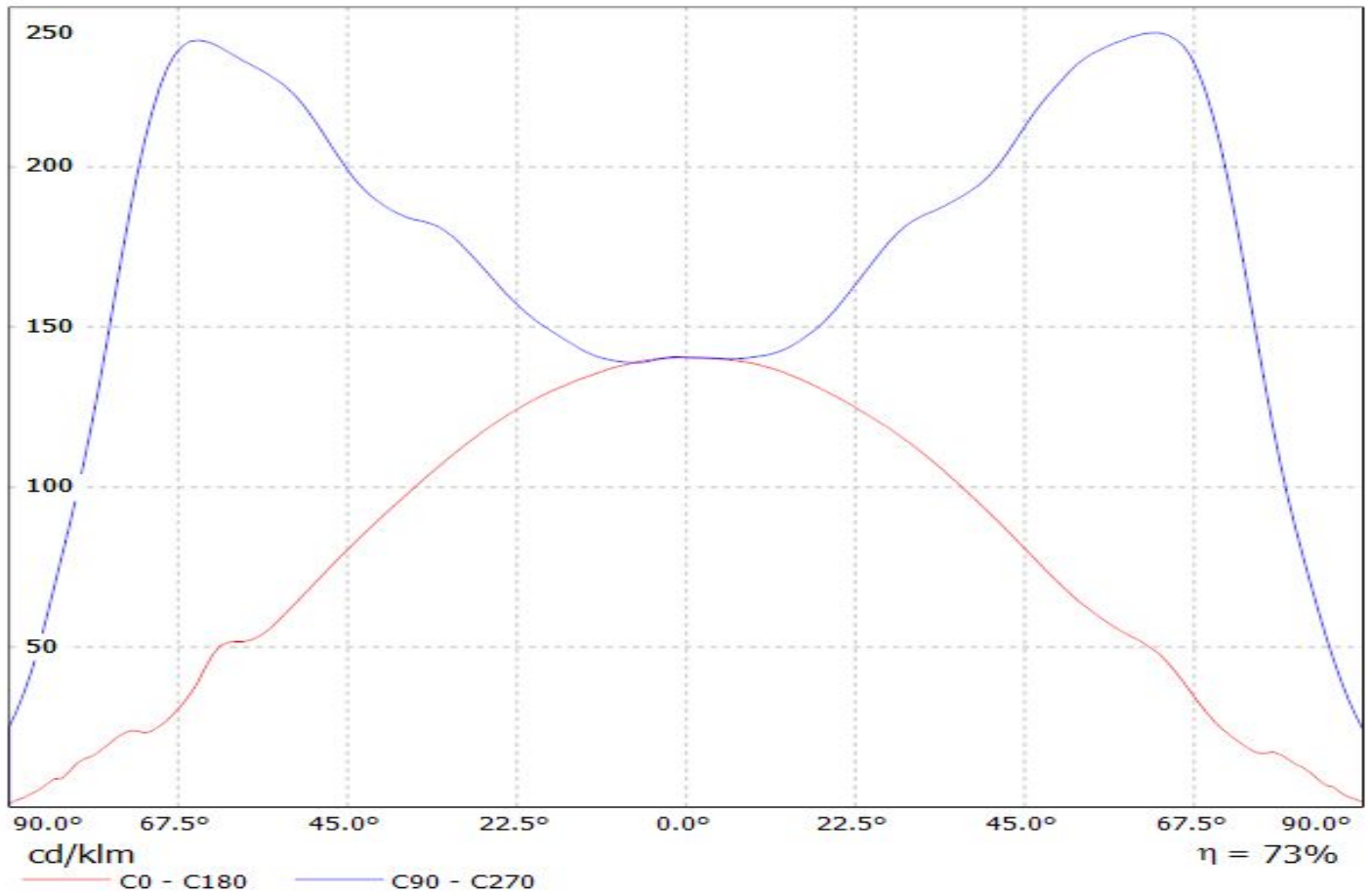

Luminaire: Ledil F16048_LINNEA-UP_(LT-S282H)

Lamps: 1 x Samsung_LT-S282H_(LM561B+)_1151.7lm@300mA_P=7.2015W_U=24.005V

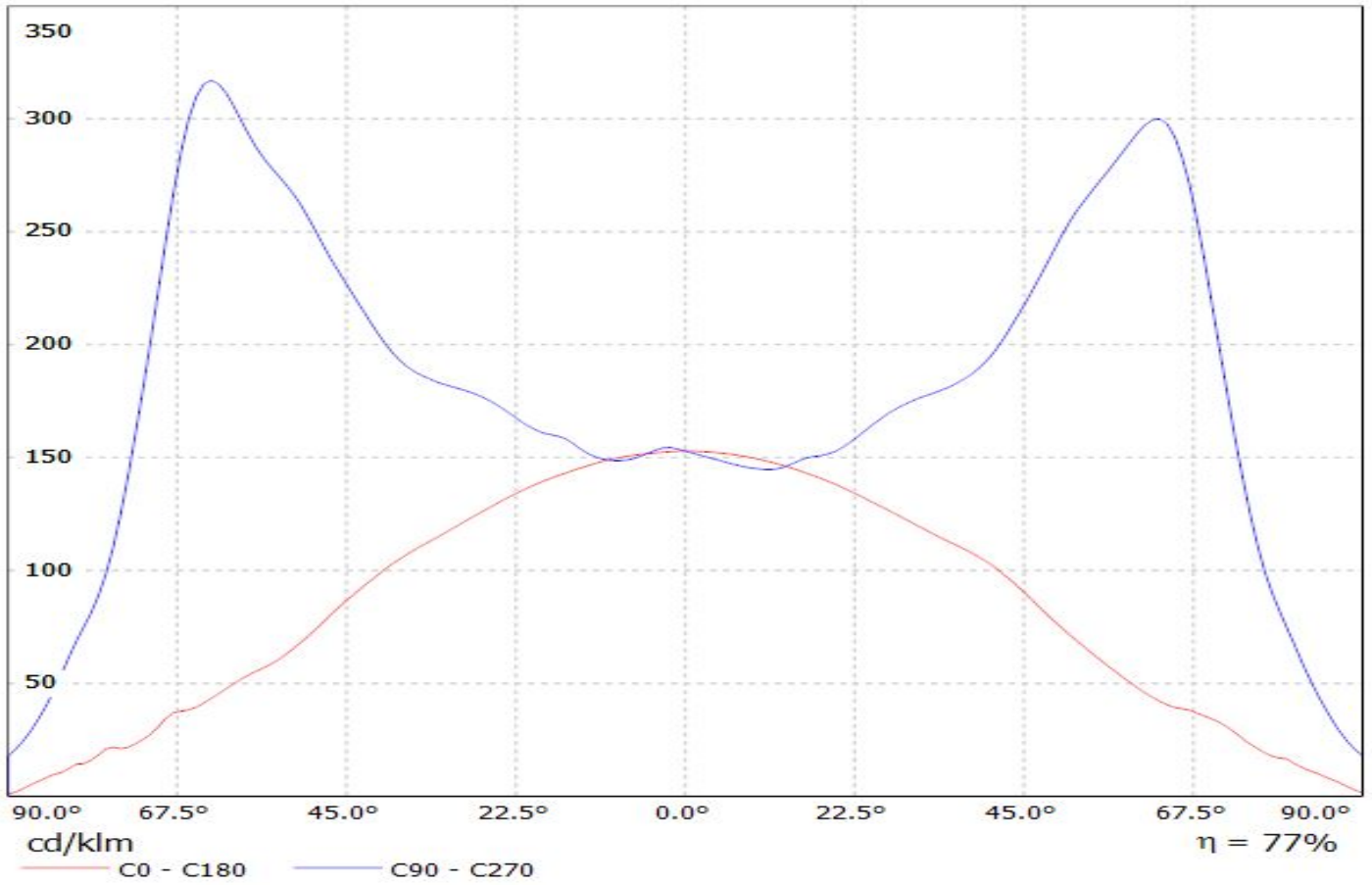

Luminaire: Ledil F16048_LINNEA-UP_(LT-Q282B)

Lamps: 1 x Samsung_LT-Q282B_(LM301B_SI-B8T053280EU)_943.526lm@180mA_P=4.99618W_U=27.805V

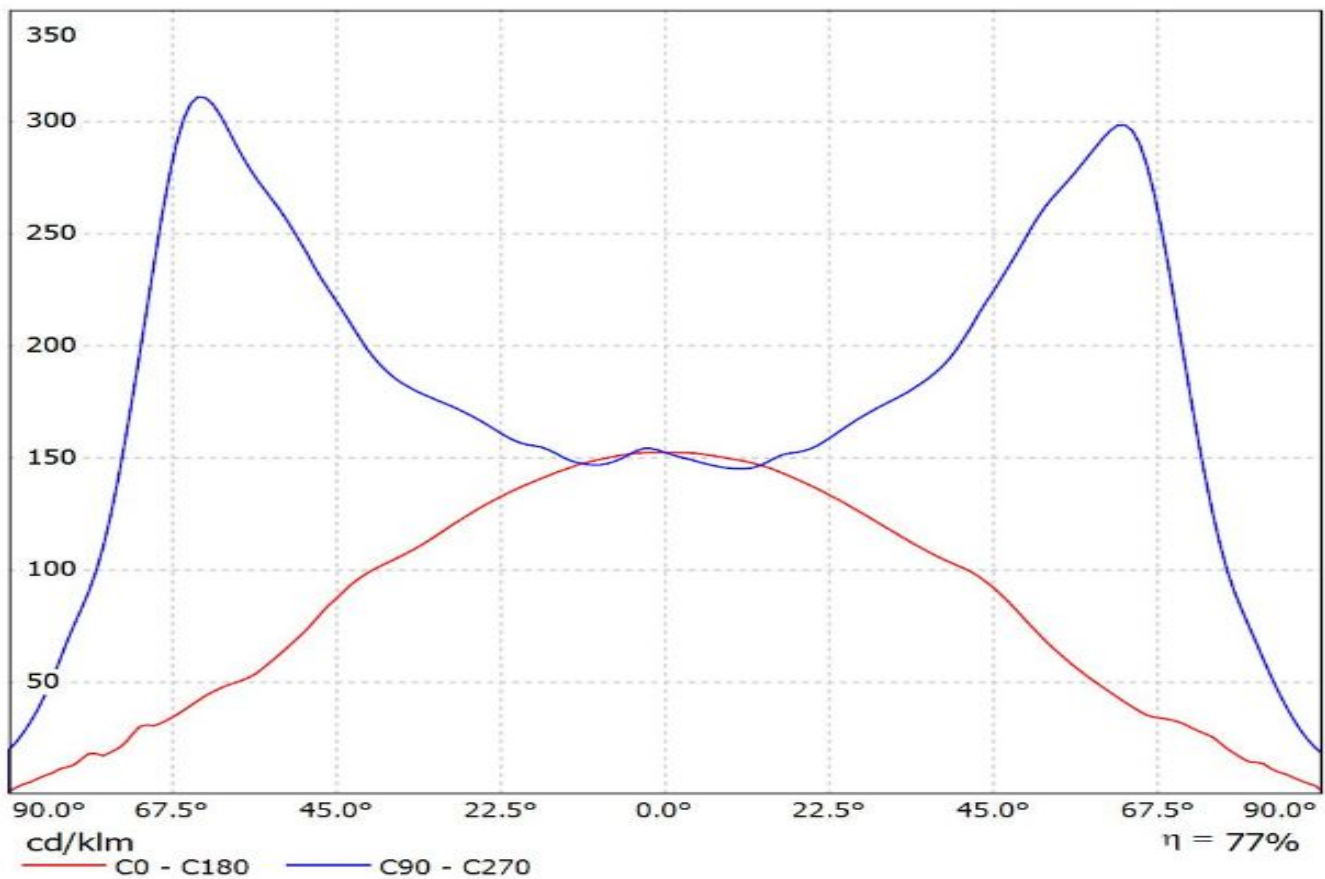

Luminaire: LEDiL Oy F16048_LINNEA-UP_(LT-H282C)

Lamps: 1 x Samsung_LT-H282C_(LM561C)_1003.19lm@240mA_CCT=4000K_P=5.41512W_U=22.562V

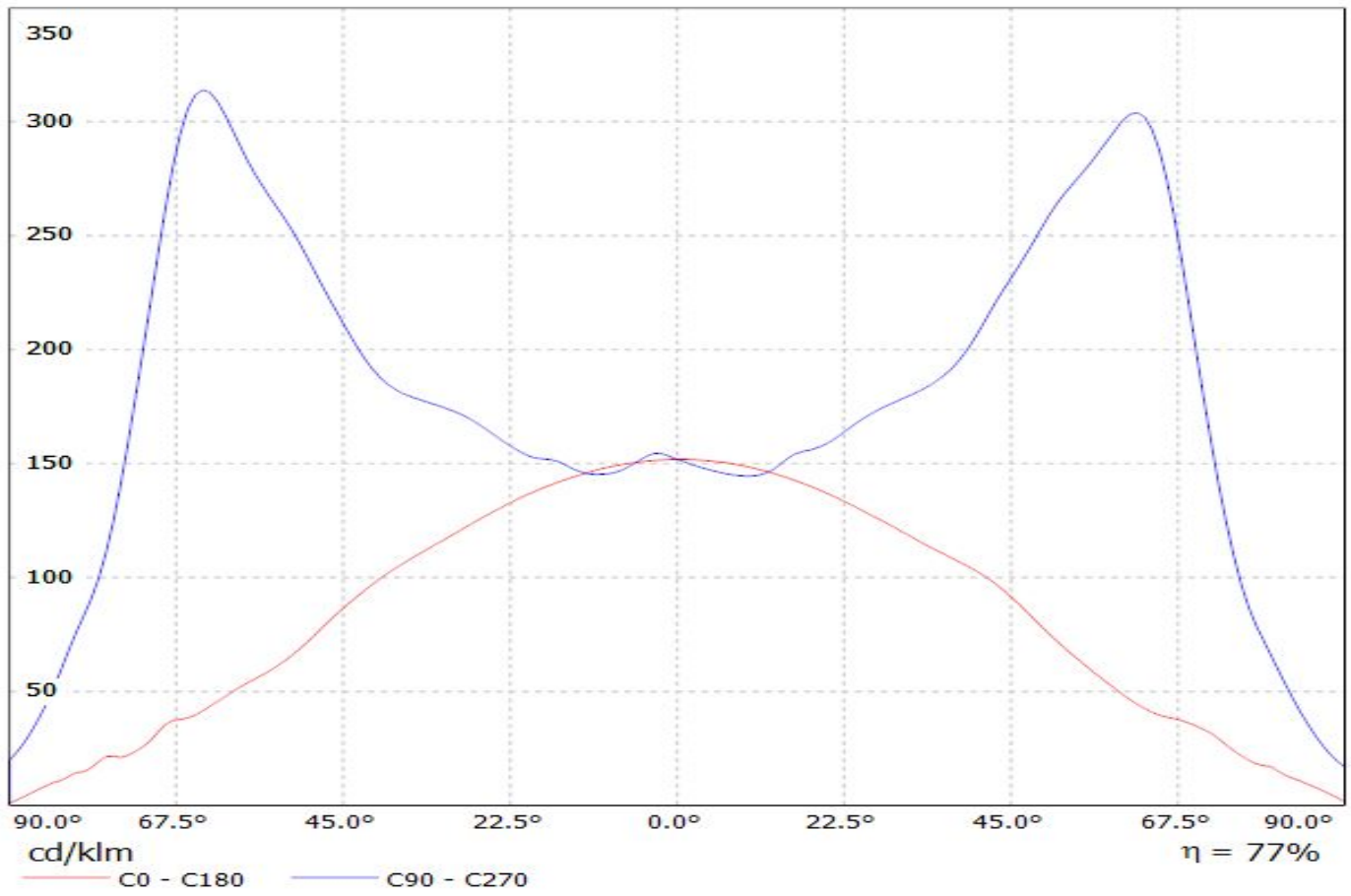

Luminaire: Ledil F16048 LINNEA-UP_(LT-V282E)

Lamps: 1 x Samsung_LT-V282E_1080.75lm@300mA_CCT=4000K_P=7.1421W_U=23.807V

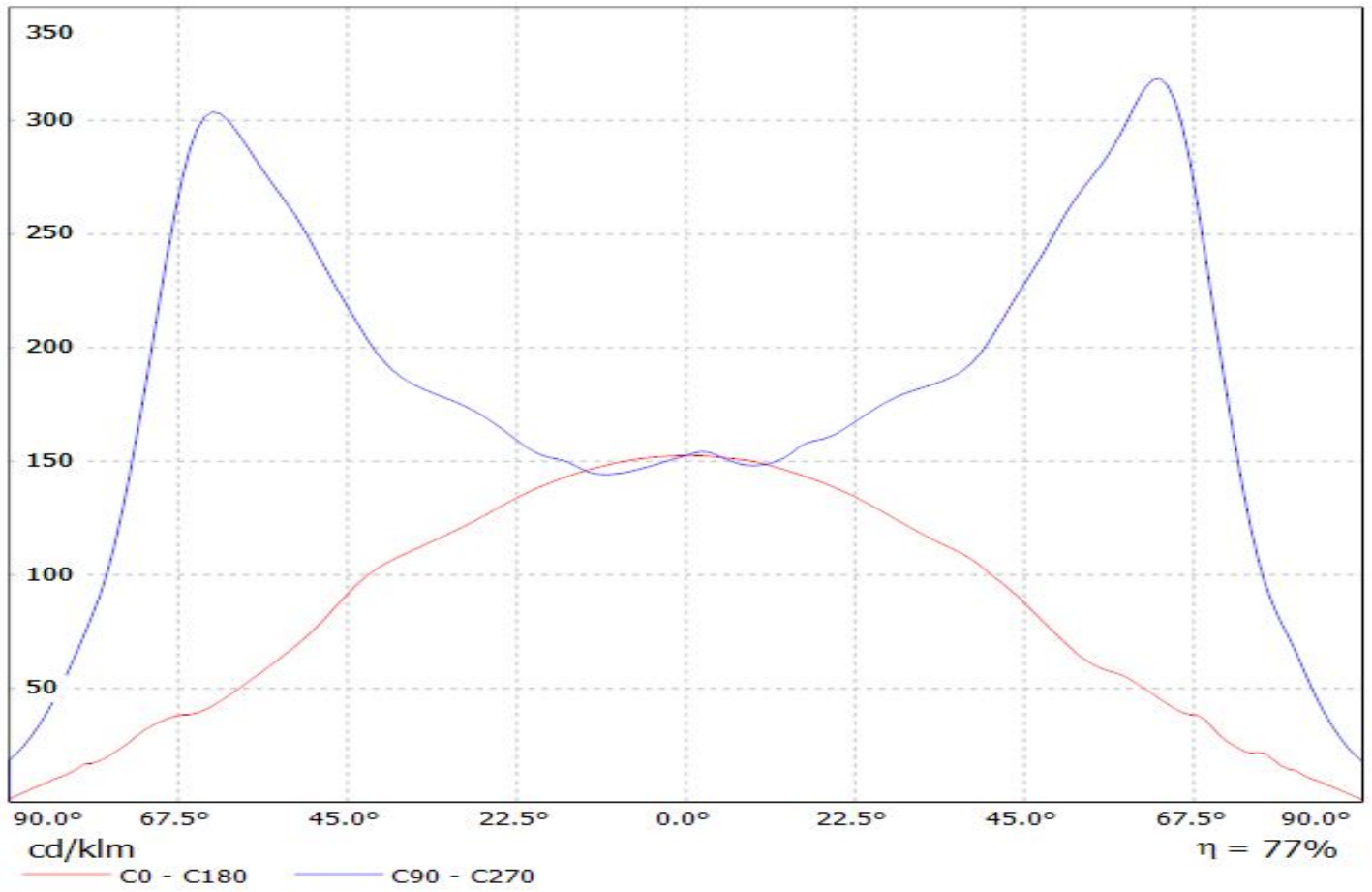

Luminaire: Ledil F16048_LINNEA-UP (SunLike 3030)

Lamps: 1 x SEOUL_SunLike 3030_(STW9C2PB-S)_2_240.649lm@0.65mA_P=2.30531W_U=35.538V

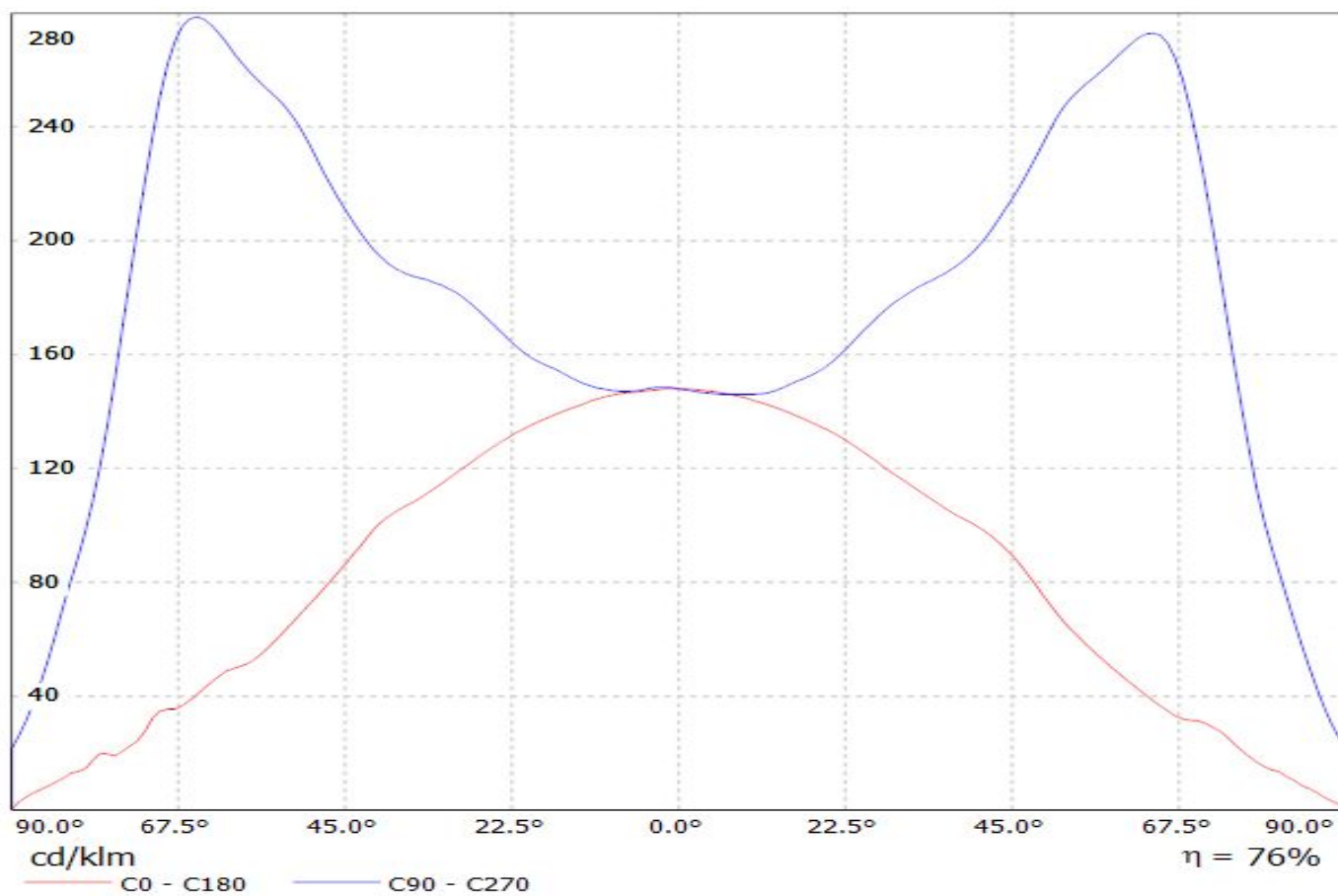

Luminaire: LEDiL Oy F16048_LINNEA-UP_(LLE_G4_24x280mm_650lm_840_2T_ADV)

Lamps: 1 x

Tridonic_LLE_G4_24x280mm_650lm_840_2T_ADV_482.885lm@250mA_CCT=4000K_P=2.81637W_U=11.27V

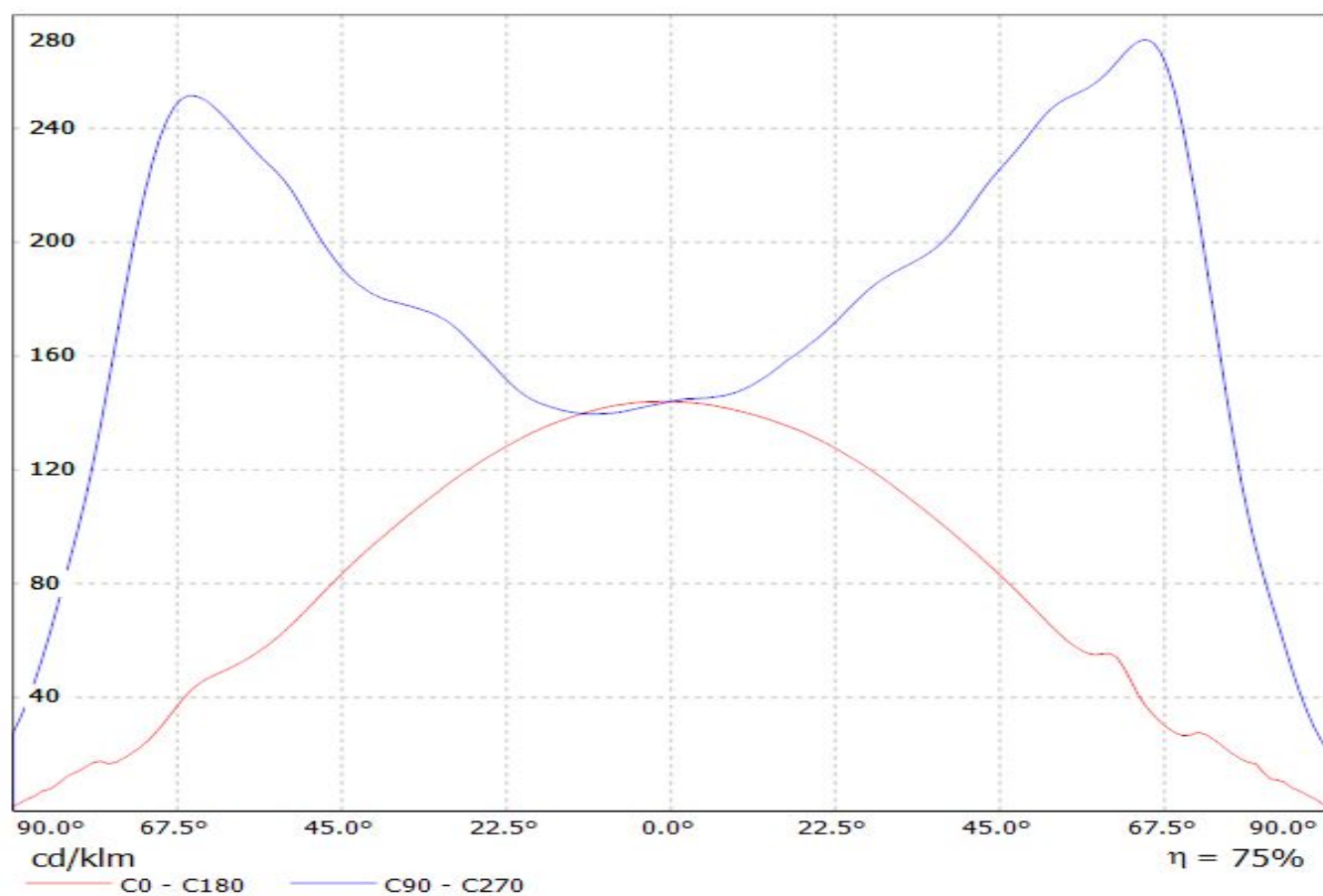

Luminaire: Ledil F16048 LINNEA-UP_(LLE_G4_24x280mm_2000lm_ADV)

Lamps: 1 x Tridonic_LLE_G4_24x280mm_2000lm_840_2T_ADV_1460.64lm@250mA_P=8.47961W_U=33.932V

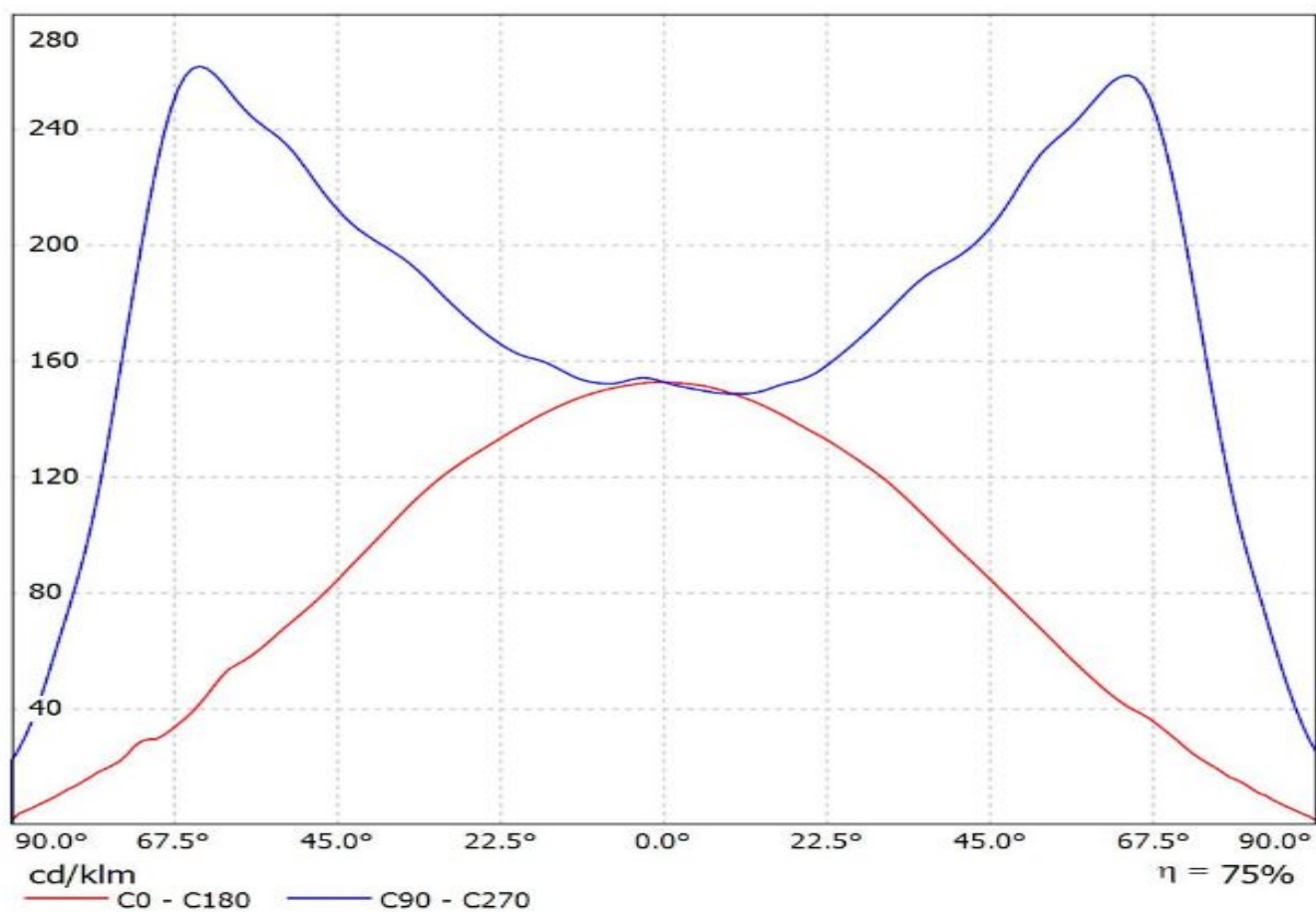

Luminaire: Ledil F16048_LINNEA-UP_(LLE_G4_24x280mm_1250lm_840_4T_ADV)
Lamps: 1 x Tridonic_(LLE_G4_24x280mm_1250lm_840_4T_ADV)
_971.78lm@250mA_CCT=4000K_P=5.6355W_U=22.5500V

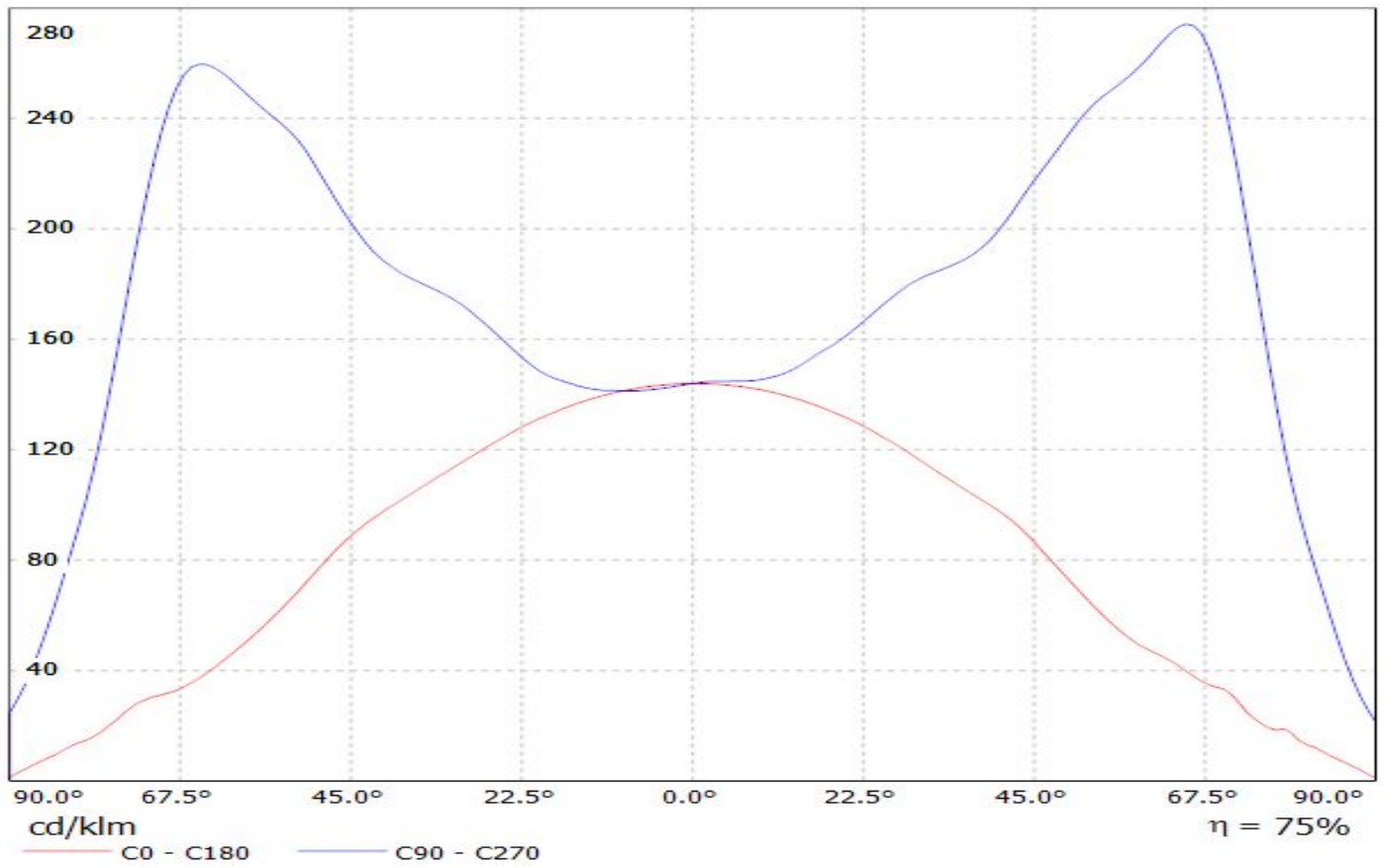

Luminaire: LEDiL Oy F16048_LINNEA-UP_(Tridino_1ft_1100lm_840HE_1R_HV)
Lamps: 1 x Tridino_1ft_1100lm_840HE_1R_HV_1215.69lm@225mA_P=7.12573W_I=0.225A

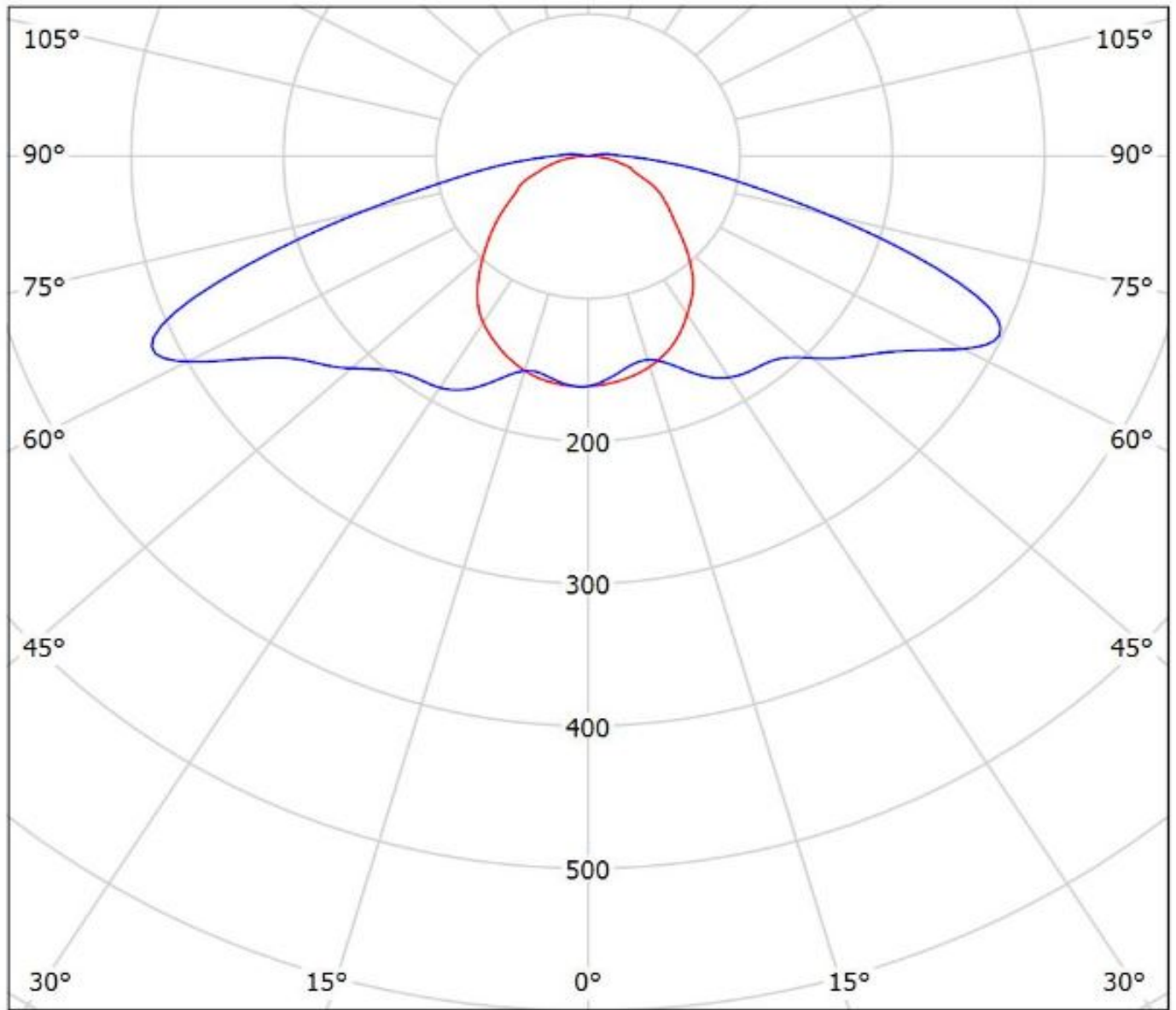

cd/klm
— C0 - C180 — C90 - C270

η = 79%

Luminaire: LEDiL Oy F16048_LINNEA-UP_(XP-E)

Lamps: 1 x Cree_XP-E_x12_(XPEWHT-L1-3C0-Q5-0-00)_920.665lm@250mA_P=9.07548W_U=36.329V

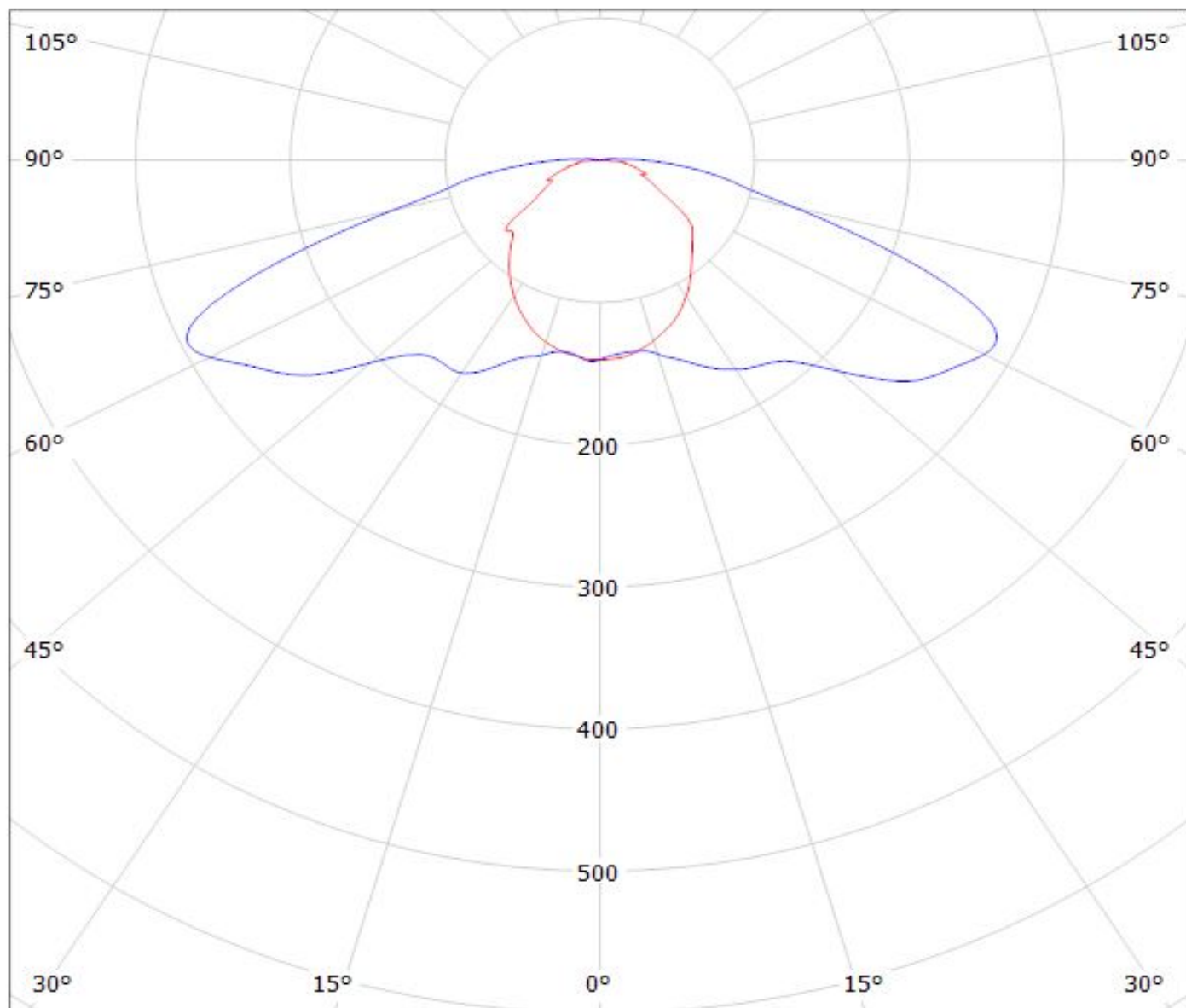

cd/klm

— C0 - C180 — C90 - C270

$\eta = 76\%$

Luminaire: LEDiL Oy F16048_LINNEA-UP_(NF2x757G)

Lamps: 1 x Nichia_NF2x757G_(NF2W757G-F1E)_387.712lm@65mA_P=2.11136W_U=30.422V

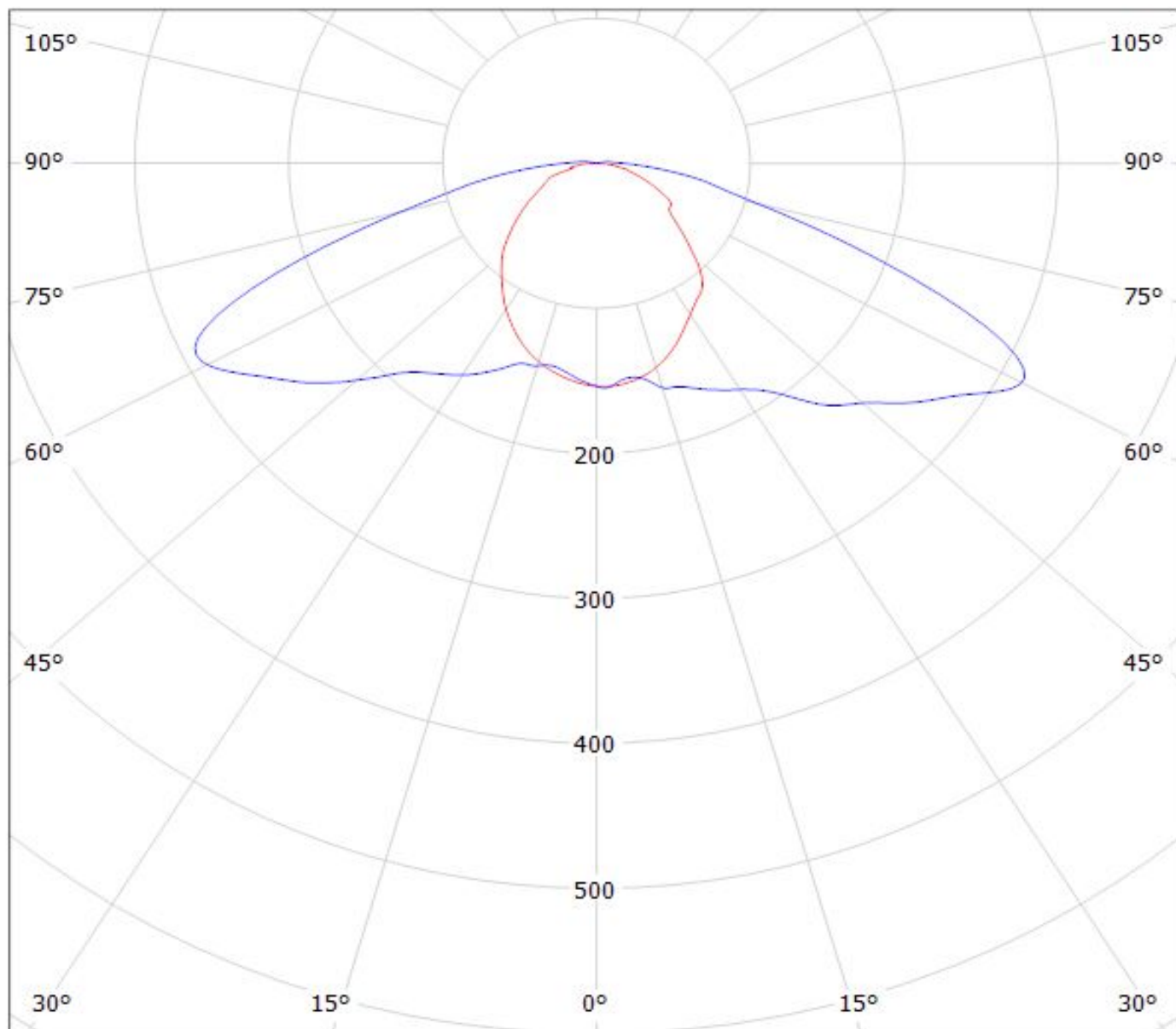

cd/klm

— C0 - C180 — C90 - C270

$\eta = 77\%$

Luminaire: Ledil F16048_LINNEA-UP_(Prevaled_Linear_Slim_1100lm)
Lamps: 1 x Osram_Prevaled_Linear_Slim_1100lm_(PL-LIN S-Z3-1100-8x0-280)
_1029.23lm@175mA_P=6.45102W_U=36.960V

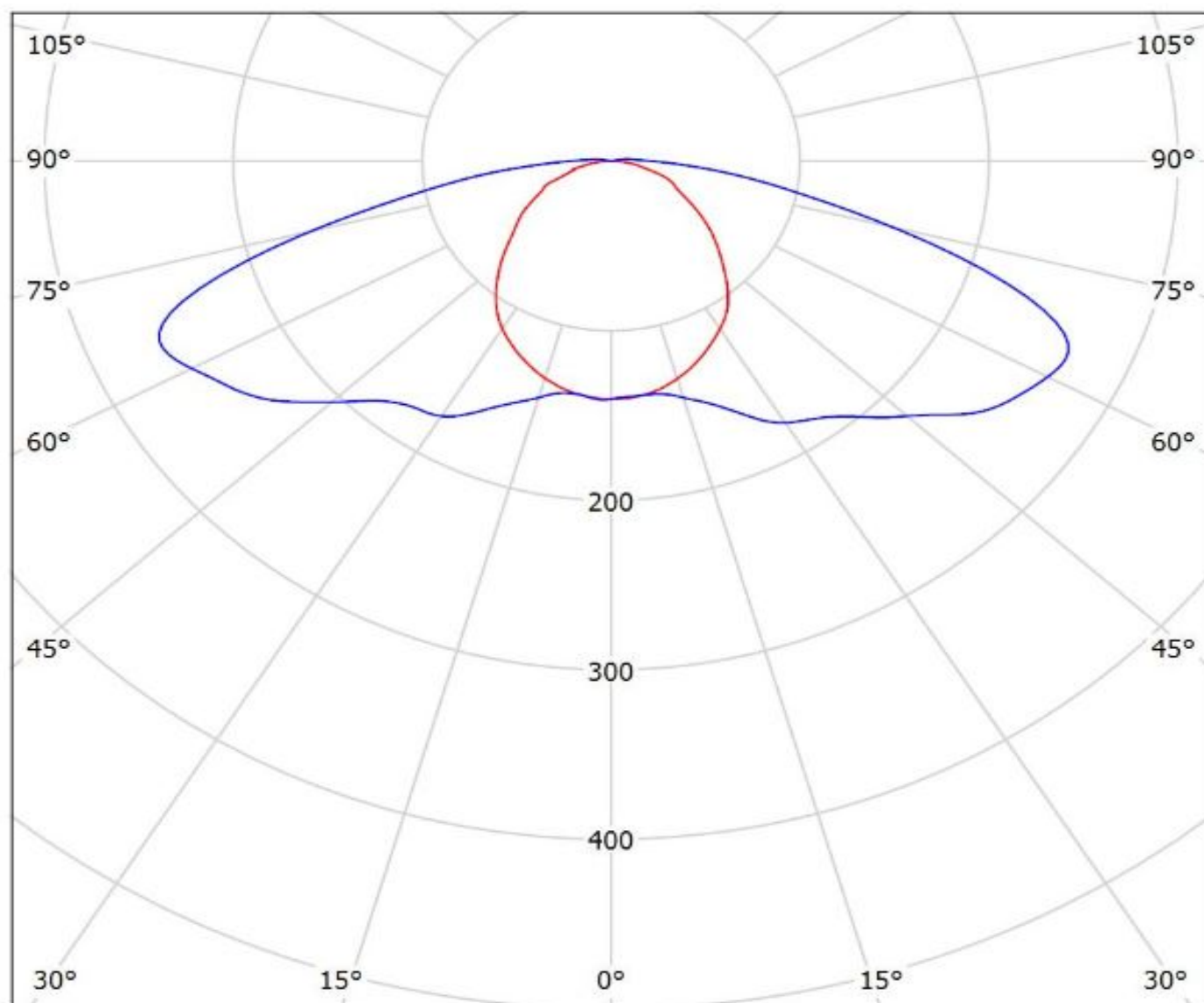

cd/klm

— C0 - C180 — C90 - C270

$\eta = 74\%$

Luminaire: Ledil F16048_LINNEA-UP_(Prevaled_Linear_Slim_3)
Lamps: 1 x Osram_Prevaled_Linear_Slim_3_(PL-LIN S-Z3-2000-840-280)
_1949.14lm@300mA_CCT=4000K_P=12.0015W_U=40.179V

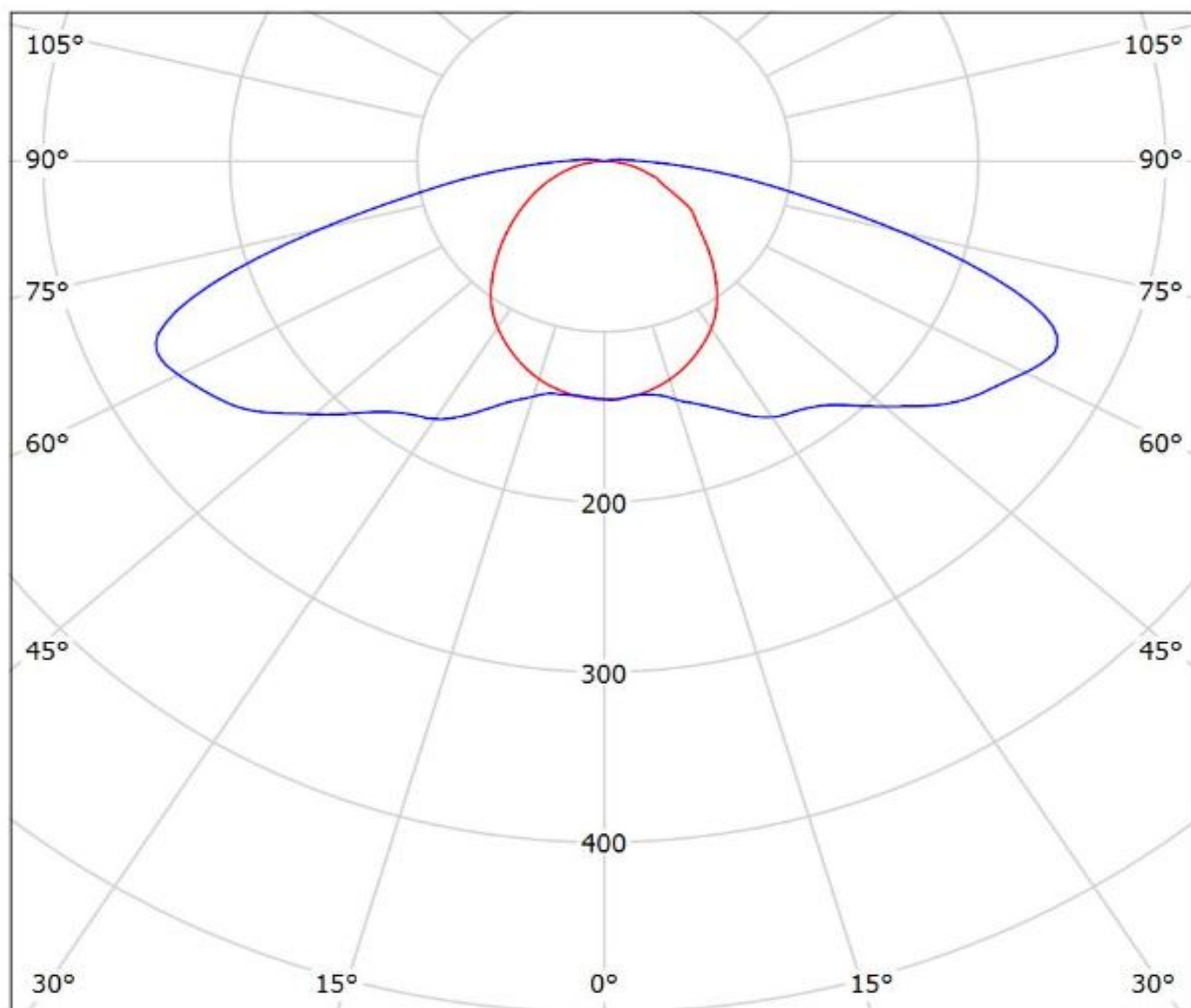

cd/klm
— C0 - C180 — C90 - C270

$\eta = 74\%$

Luminaire: Ledil F16048_LINNEA-UP_(Duris_S5)

Lamps: 1 x Osram_Duris_S5_1183.73lm@250mA_P=8.66003W_U=34.724V

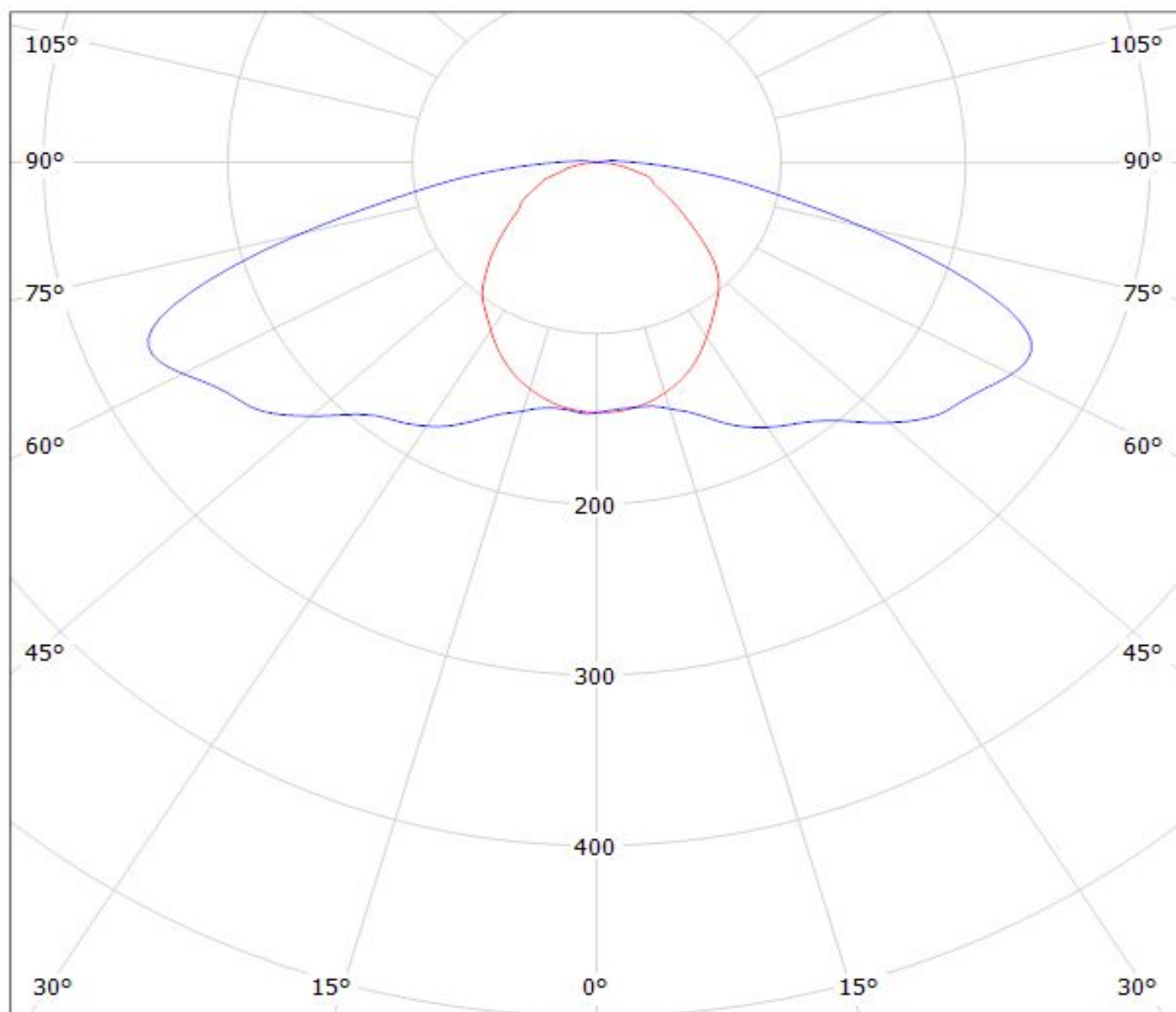

cd/klm

— C0 - C180 — C90 - C270

$\eta = 75\%$

Luminaire: LEDiL Oy F16048_LINNEA-UP_(Duris_S5_1chip)
Lamps: 1 x Osram_Duris_S5_1chip_(GWPSLM31_EM-GUHQ-A535-1)
_359.255lm@65mA_P=2.13817W_U=33.253V

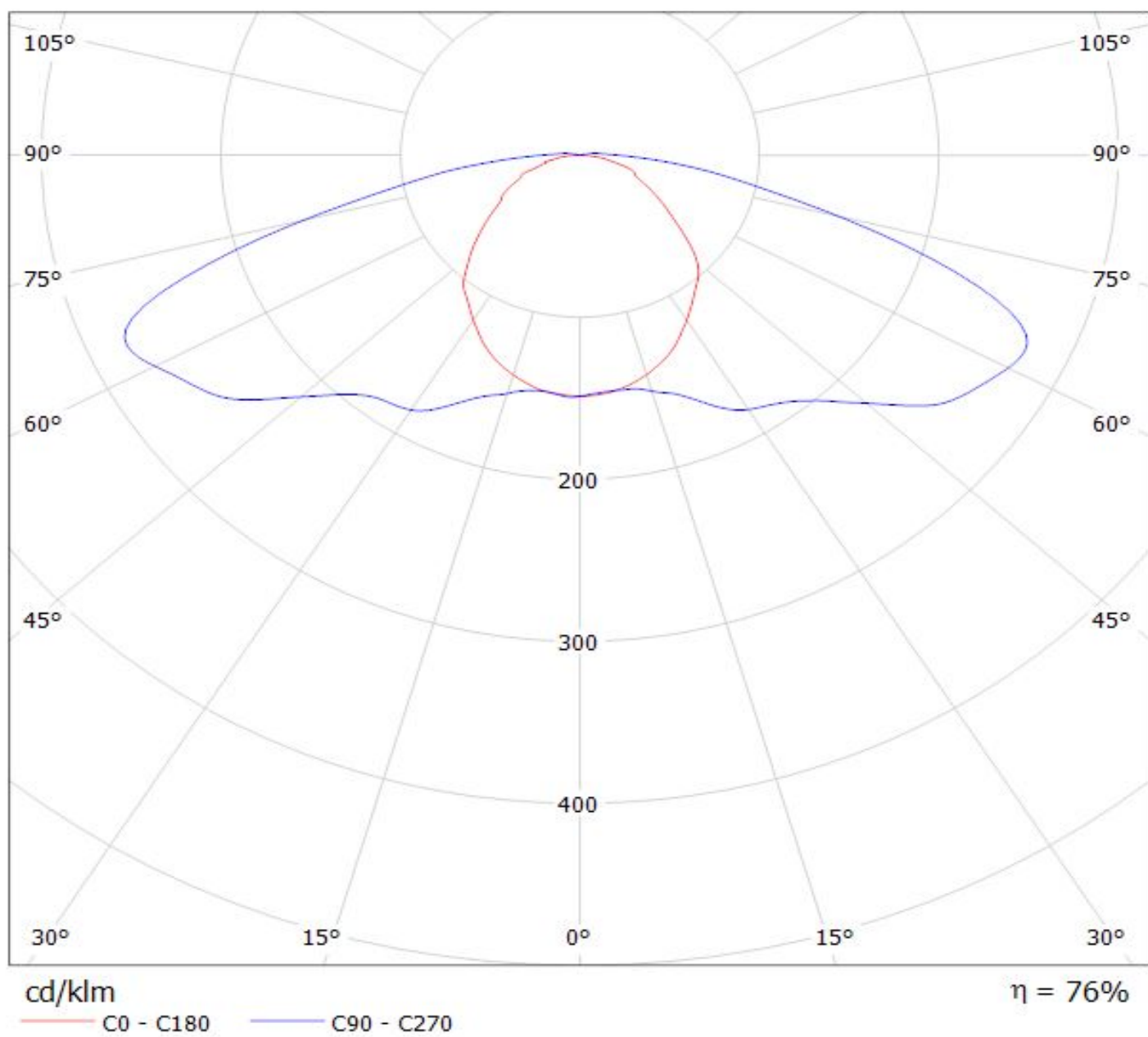

Luminaire: Ledil F16048_LINNEA-UP_(Fortimo_LED_Strip_1ft_1100lm_FC_HV4)

Lamps: 1 x Philips_Fortimo_LED_Strip_1ft_1100lm_930_FC_HV4_735.772lm@250mA_P=5.6145W_U=22.496V

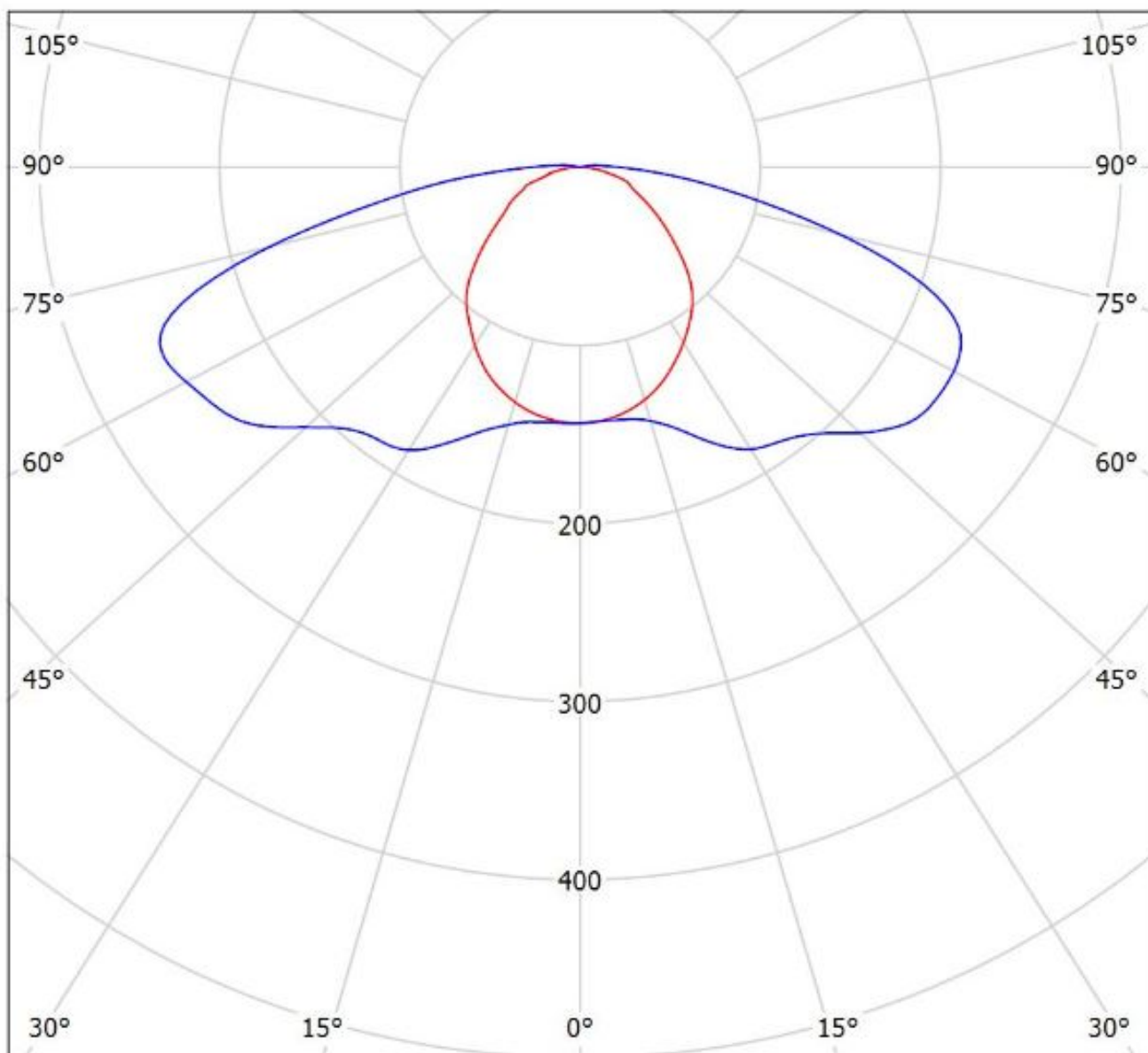

cd/klm

— C0 - C180 — C90 - C270

$\eta = 73\%$

Luminaire: Ledil F16048_LINNEA-UP_(Fortimo_LED_Strip_1ft_650lm_FC_LV4)

Lamps: 1 x Philips_Fortimo_LED_Strip_1ft_650lm_FC_LV4_994.849lm@190mA_P=6.82273W_U=35.990V

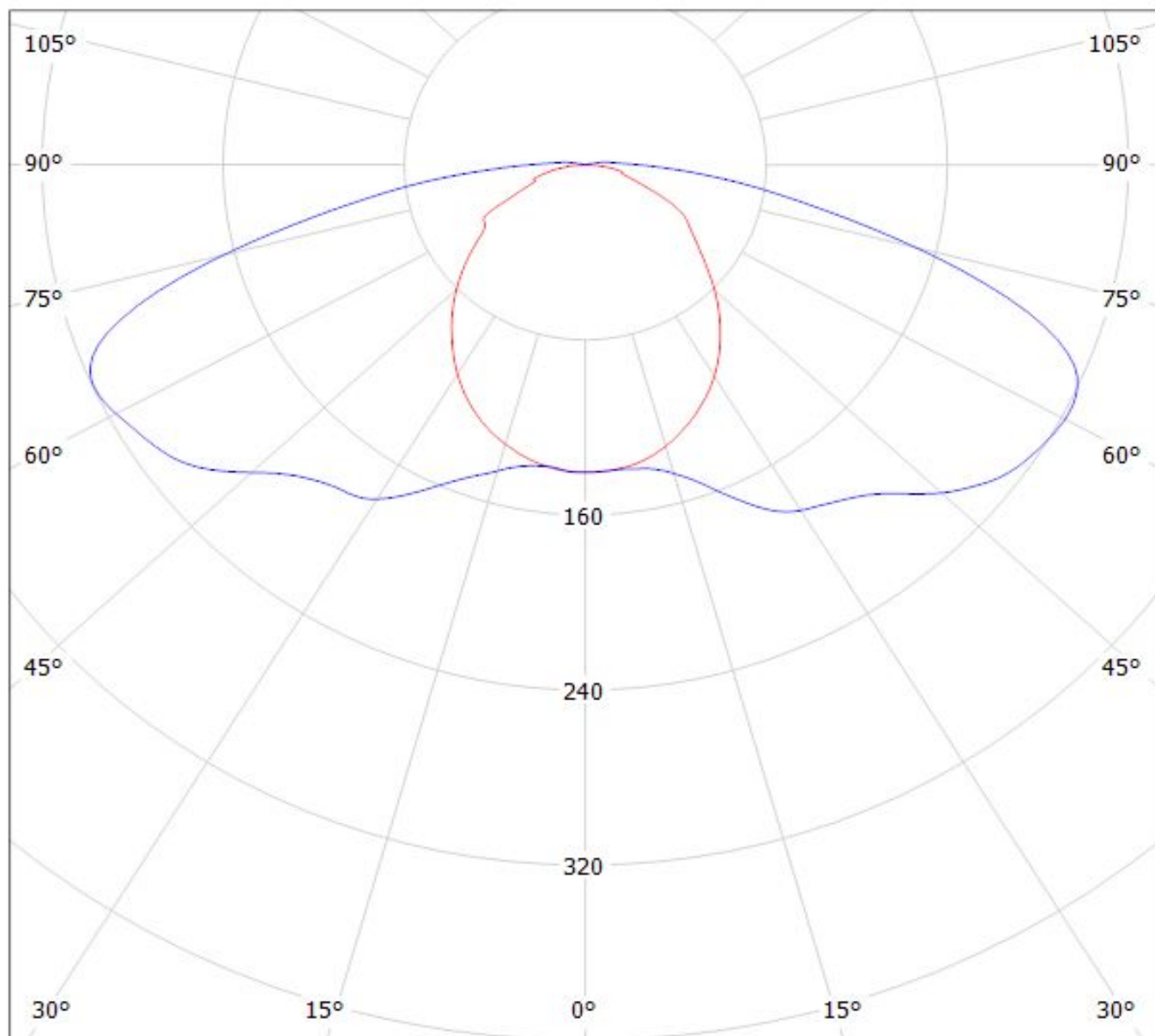

cd/klm

— C0 - C180 — C90 - C270

$\eta = 73\%$

Luminaire: Ledil F16048_LINNEA-UP_(LT-S282H)

Lamps: 1 x Samsung_LT-S282H_(LM561B+)_1151.7lm@300mA_P=7.2015W_U=24.005V

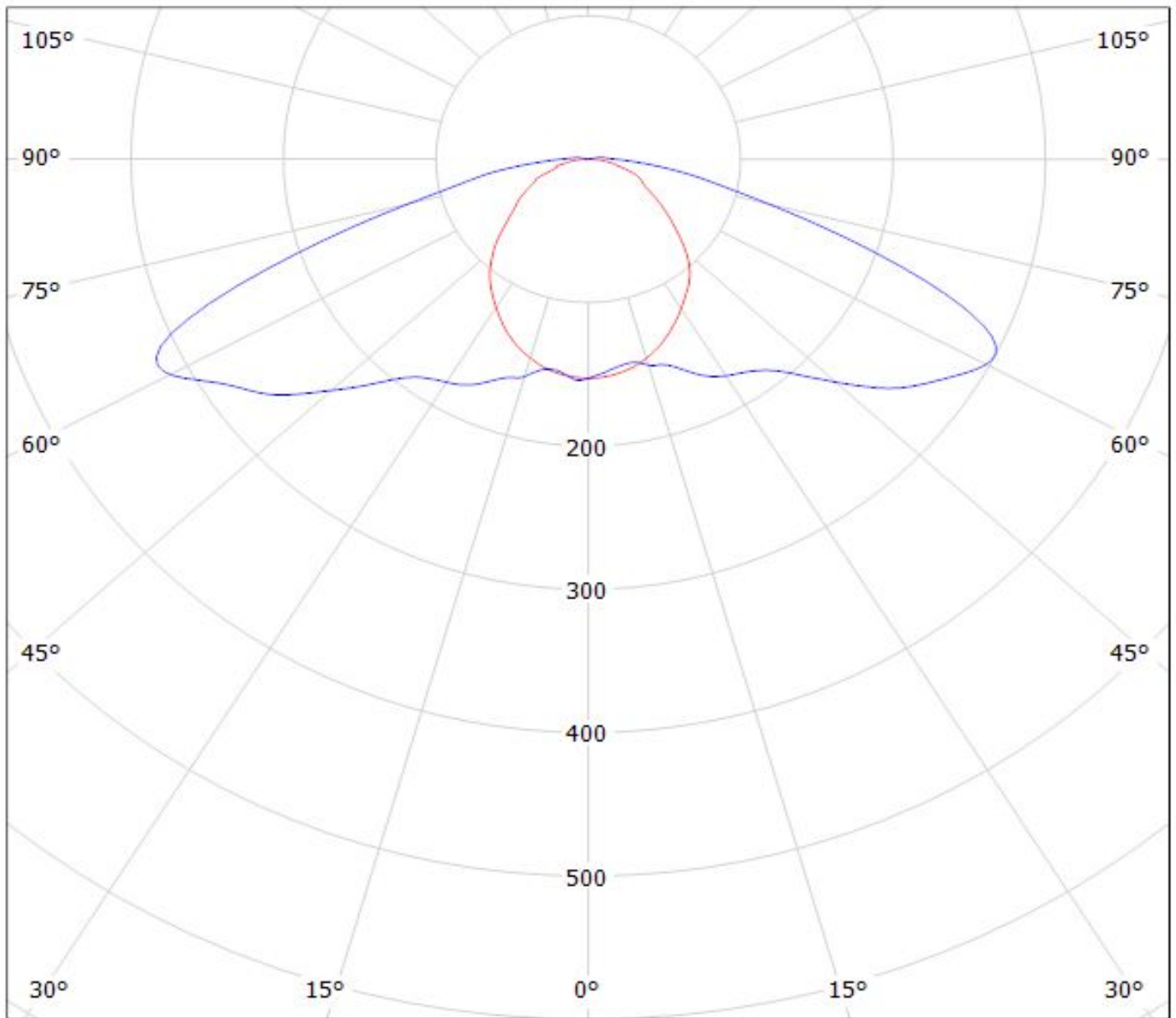

cd/klm

— C0 - C180 — C90 - C270

$\eta = 77\%$

Luminaire: Ledil F16048_LINNEA-UP_(LT-Q282B)

Lamps: 1 x Samsung_LT-Q282B_(LM301B_SI-B8T053280EU)_943.526lm@180mA_P=4.99618W_U=27.805V

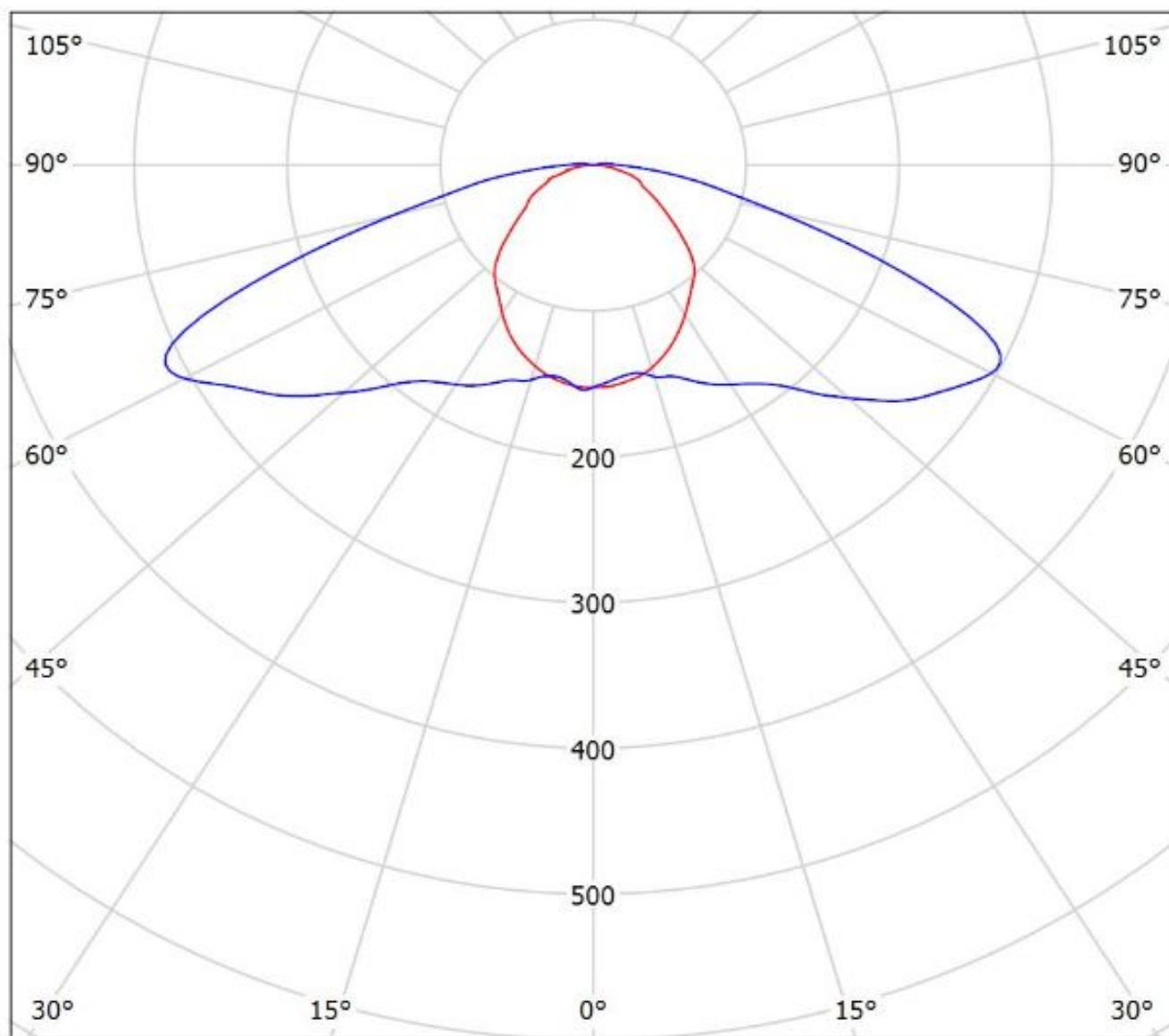

cd/klm

— C0 - C180 — C90 - C270

$\eta = 77\%$

Luminaire: LEDiL Oy F16048_LINNEA-UP_(LT-H282C)

Lamps: 1 x Samsung_LT-H282C_(LM561C)_1003.19lm@240mA_CCT=4000K_P=5.41512W_U=22.562V

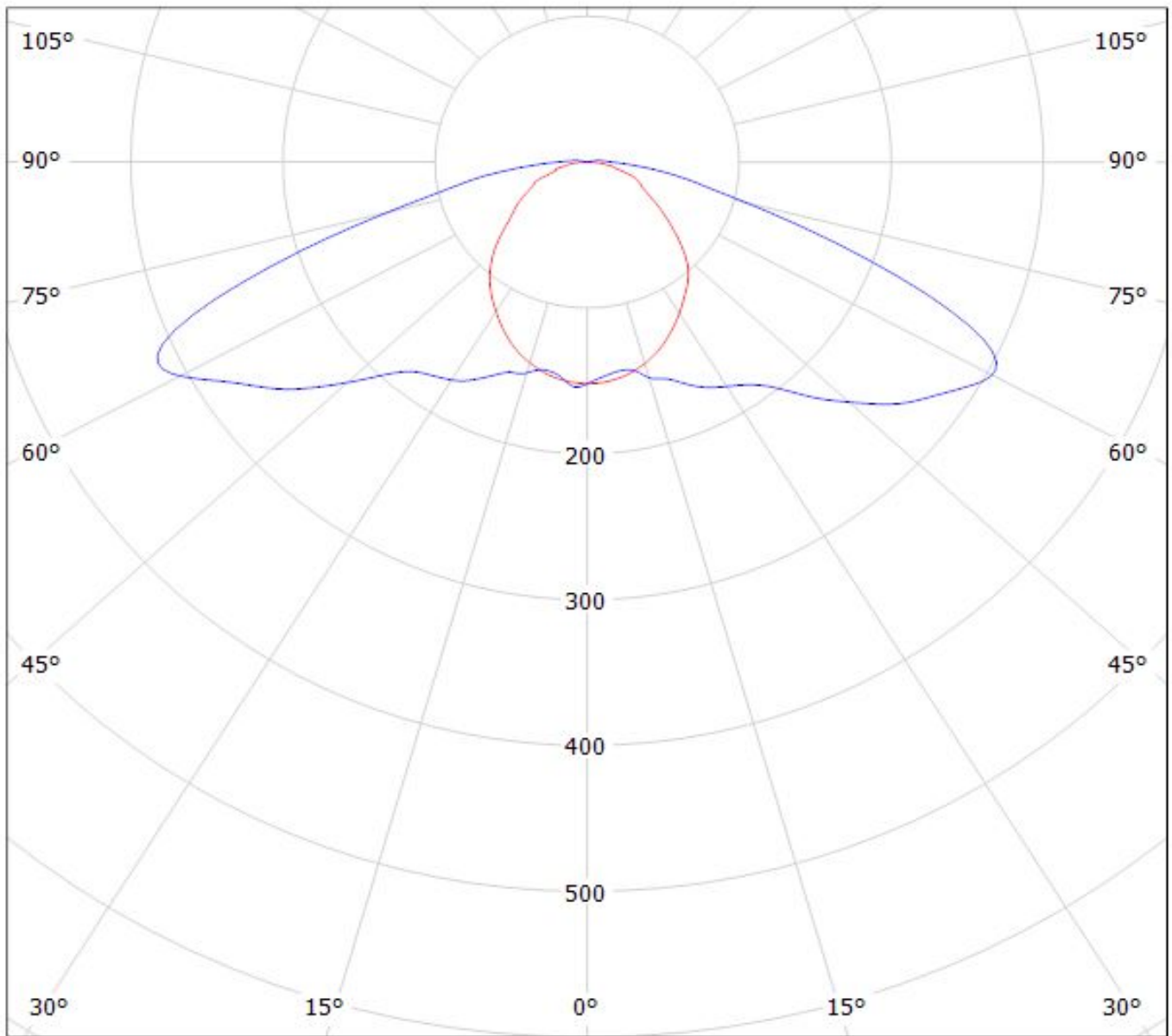

cd/klm

— C0 - C180 — C90 - C270

$\eta = 77\%$

Luminaire: Ledil F16048 LINNEA-UP_(LT-V282E)

Lamps: 1 x Samsung_LT-V282E_1080.75lm@300mA_CCT=4000K_P=7.1421W_U=23.807V

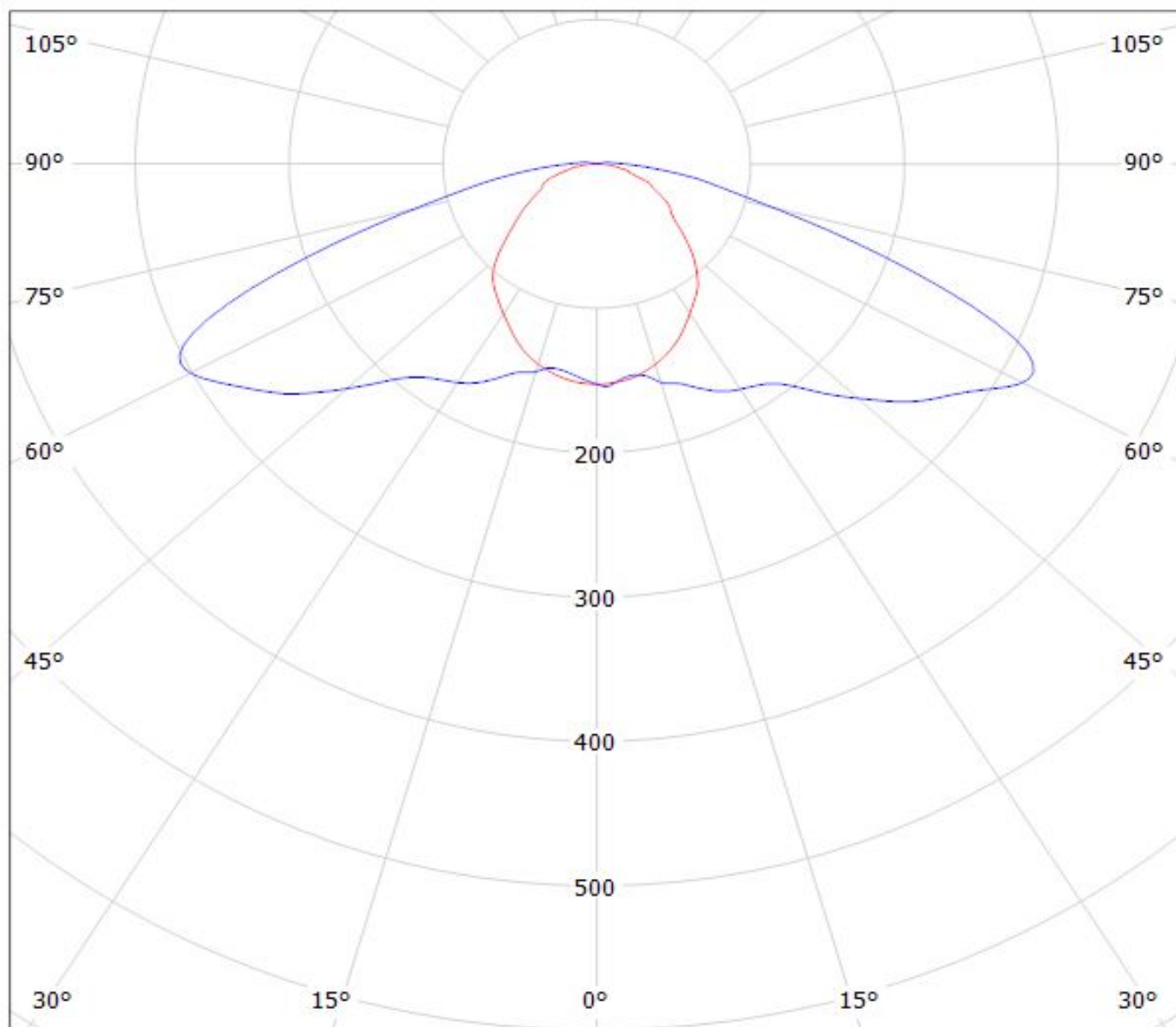

cd/klm

— C0 - C180 — C90 - C270

$\eta = 77\%$

Luminaire: Ledil F16048_LINNEA-UP_(SunLike 3030)

Lamps: 1 x SEOUL_SunLike 3030_(STW9C2PB-S)_2_240.649lm@0.65mA_P=2.30531W_U=35.538V

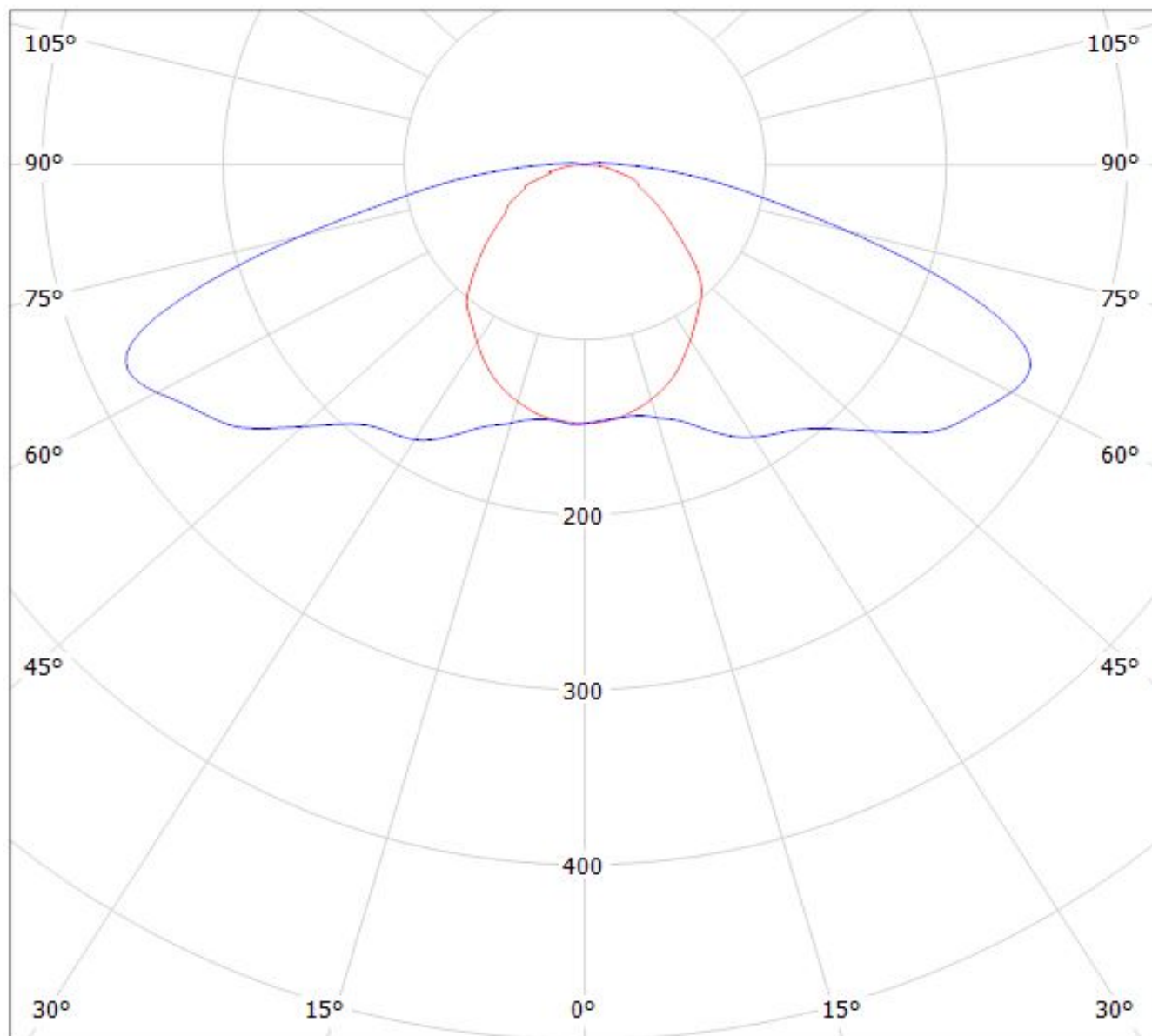

cd/klm

— C0 - C180 — C90 - C270

$\eta = 76\%$

Luminaire: LEDiL Oy F16048_LINNEA-UP_(LLE_G4_24x280mm_650lm_840_2T_ADV)

Lamps: 1 x

Tridonic_LLE_G4_24x280mm_650lm_840_2T_ADV_482.885lm@250mA_CCT=4000K_P=2.81637W_U=11.27V

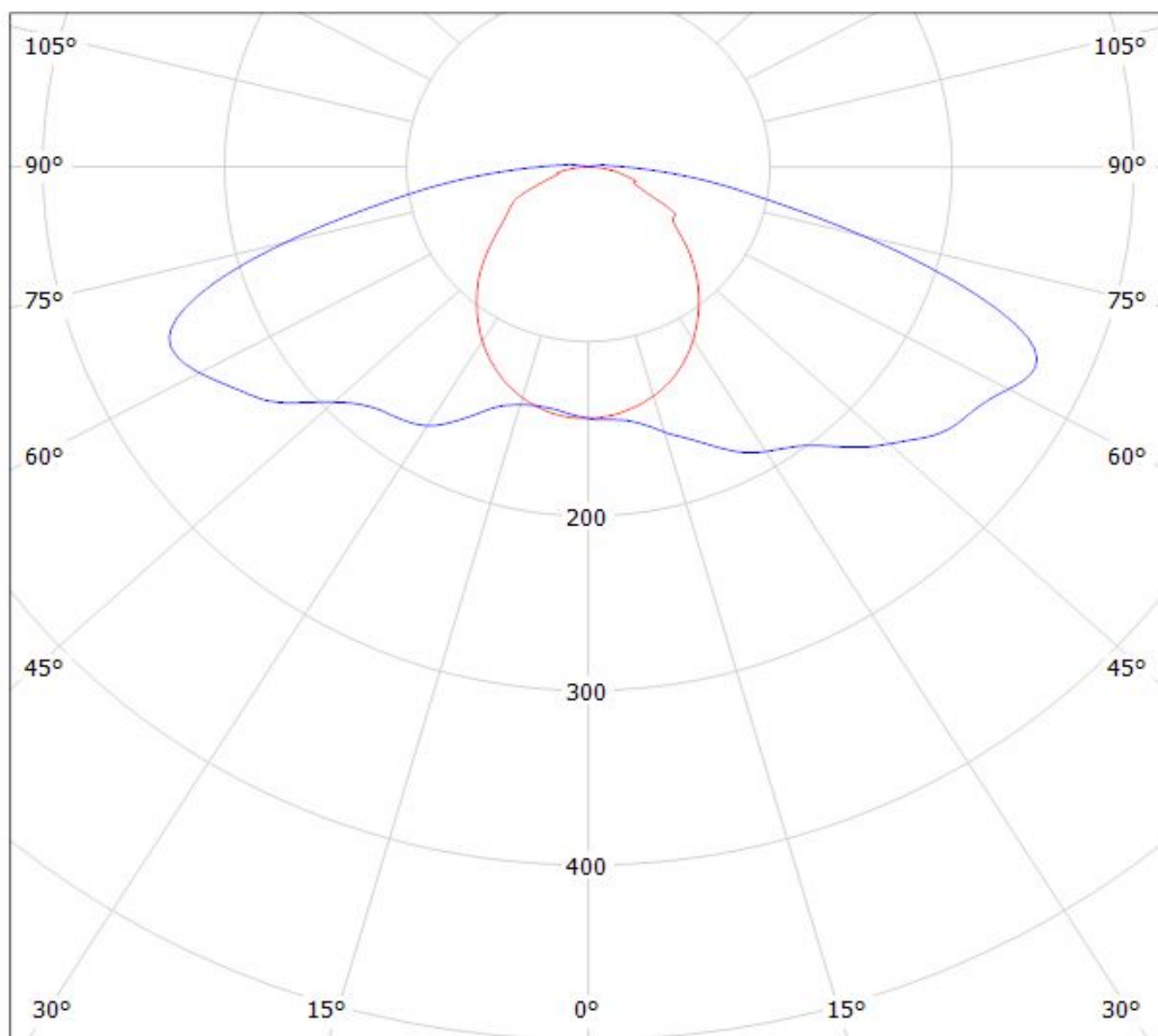

cd/klm

$\eta = 75\%$

— C0 - C180

— C90 - C270

Luminaire: Ledil F16048 LINNEA-UP_(LLE_G4_24x280mm_2000lm_ADV)

Lamps: 1 x Tridonic_LLE_G4_24x280mm_2000lm_840_2T_ADV_1460.64lm@250mA_P=8.47961W_U=33.932V

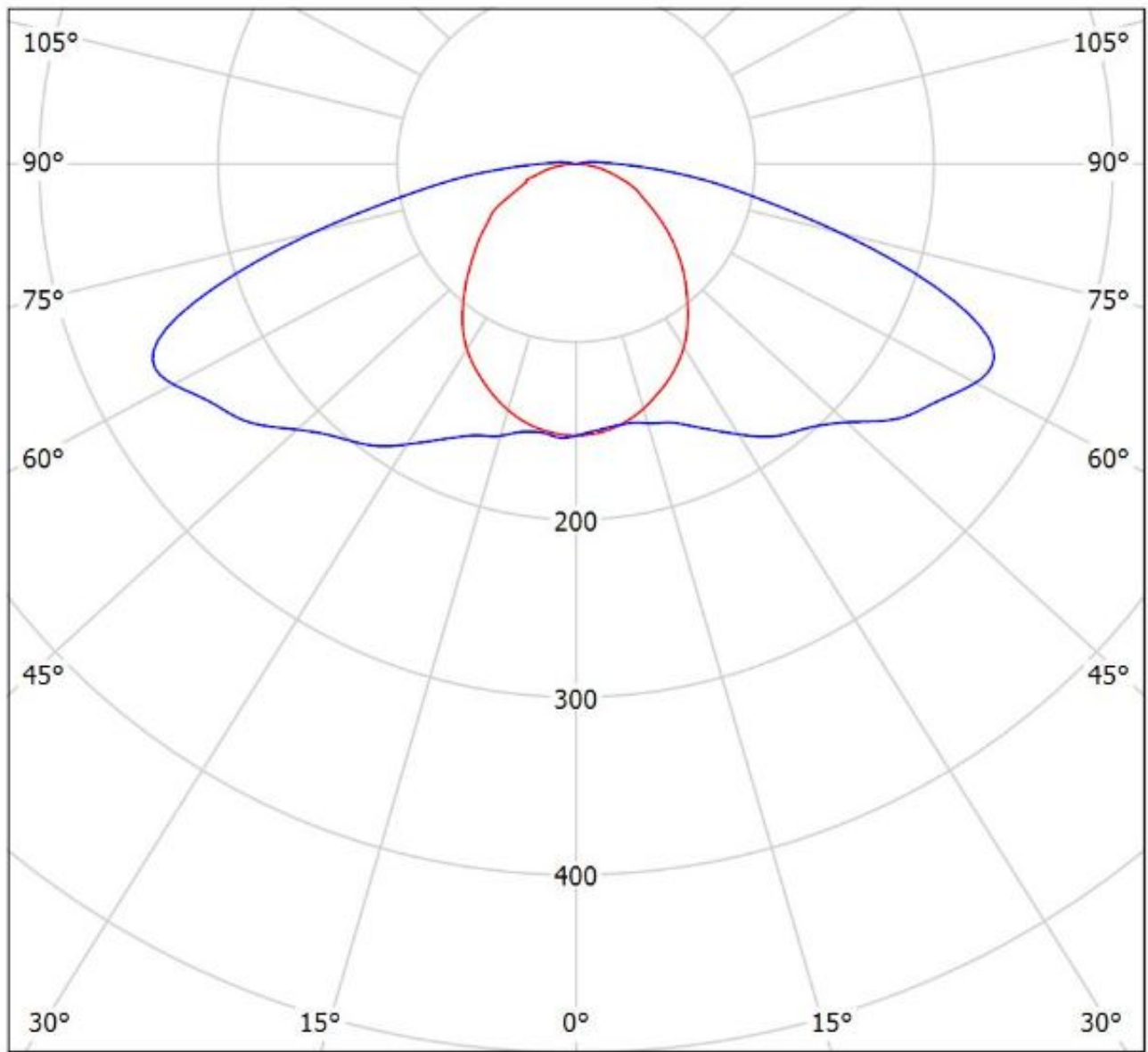

cd/klm

— C0 - C180 — C90 - C270

$\eta = 75\%$

Luminaire: Ledil F16048_LINNEA-UP_(LLE_G4_24x280mm_1250lm_840_4T_ADV)
Lamps: 1 x Tridonic_(LLE_G4_24x280mm_1250lm_840_4T_ADV)
_971.78lm@250mA_CCT=4000K_P=5.6355W_U=22.5500V

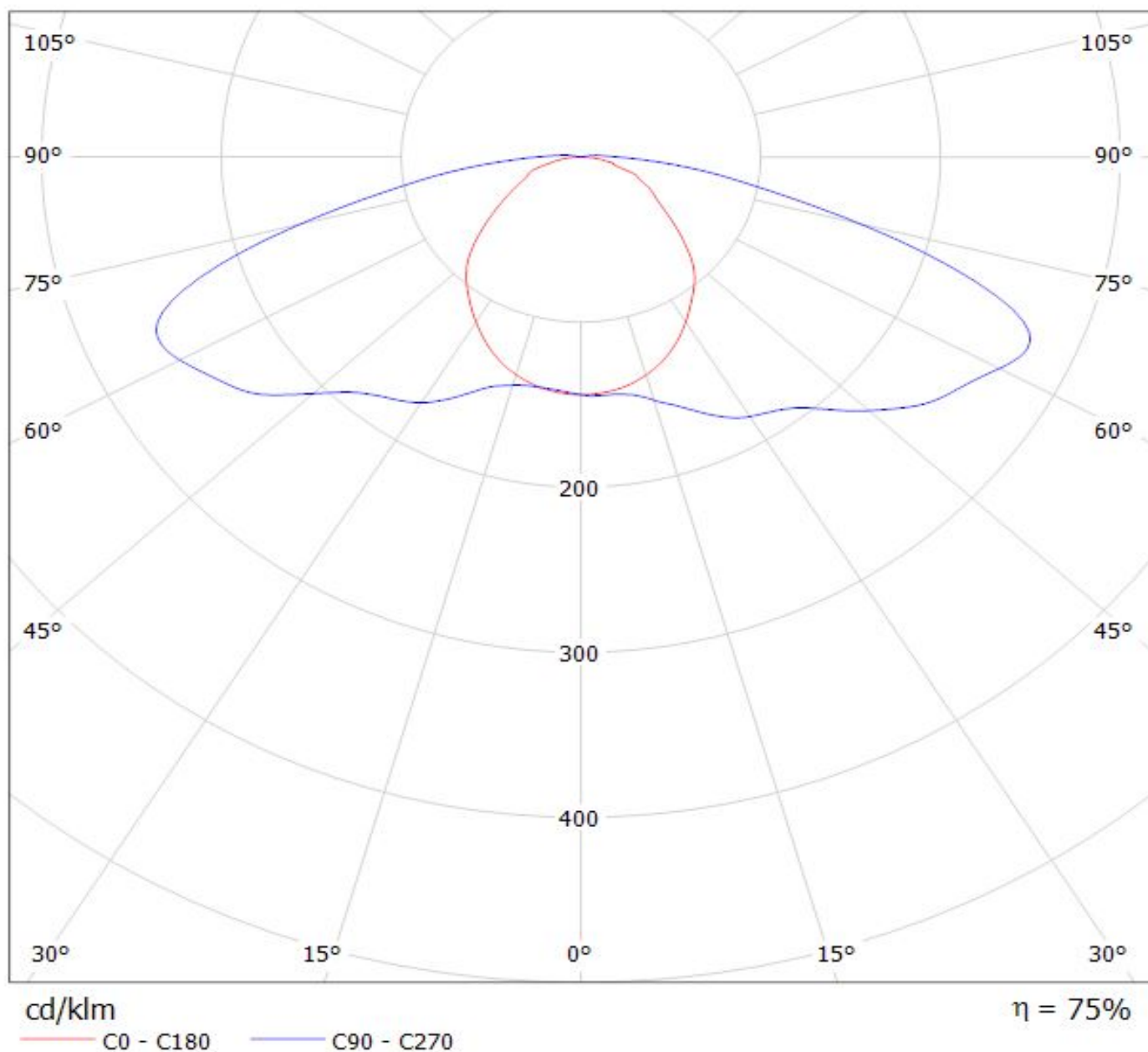

NOTE: The typical divergence will be changed by different color, chip size and chip position tolerance. The typical total divergence is the full angle measured where the luminous intensity is half of the peak value.