

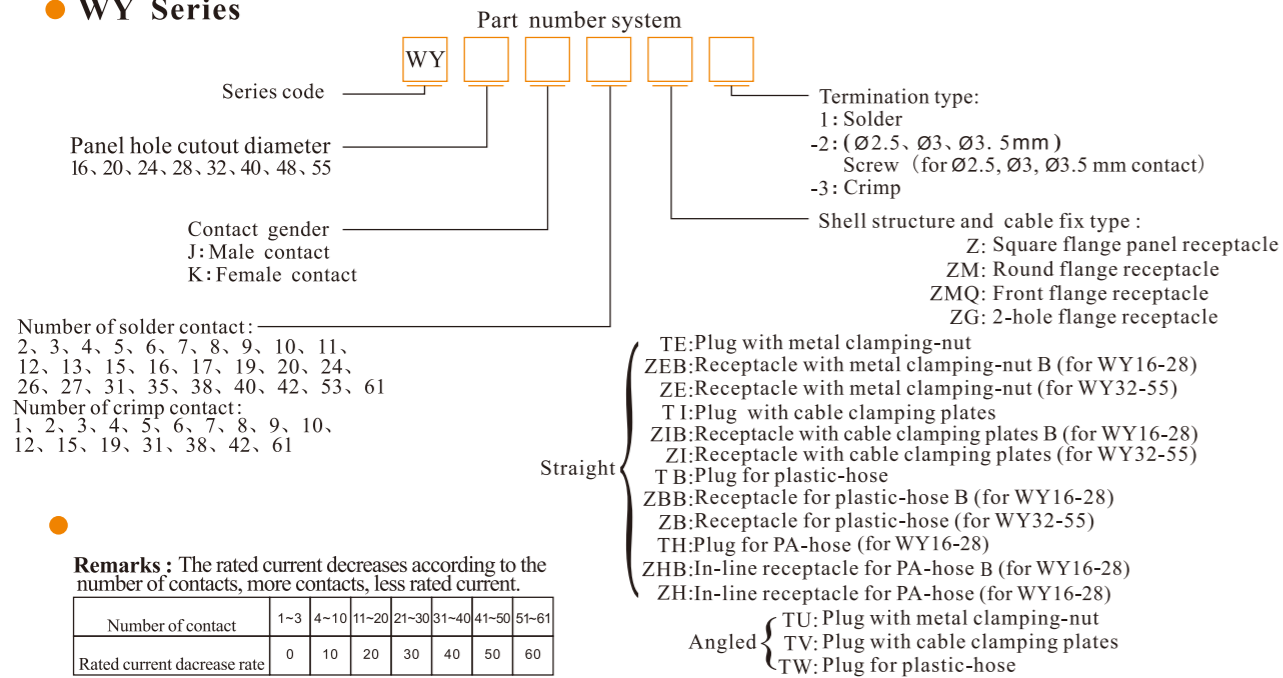

WY Series



Material and spec

Coupling	Bayonet
Shell material	Zinc alloy with chrome plating
Insert material	PPS, max temperature 260 °C
Contact material	Brass with gold plating
Termination	Solder: Ø0.7, Ø1, Ø1.5, Ø1.6, Ø2.5, Ø3.5, Ø5.5mm; Screw: Ø2.5, Ø3, Ø3.5mm; Crimp: Ø1, Ø1.5, Ø2.5, Ø3.5, Ø5.5, Ø10mm
Mating cycle	500
Temperature range	-40°C ~ +85°C; -20°C ~ +70°C

WY Series Mating diagram

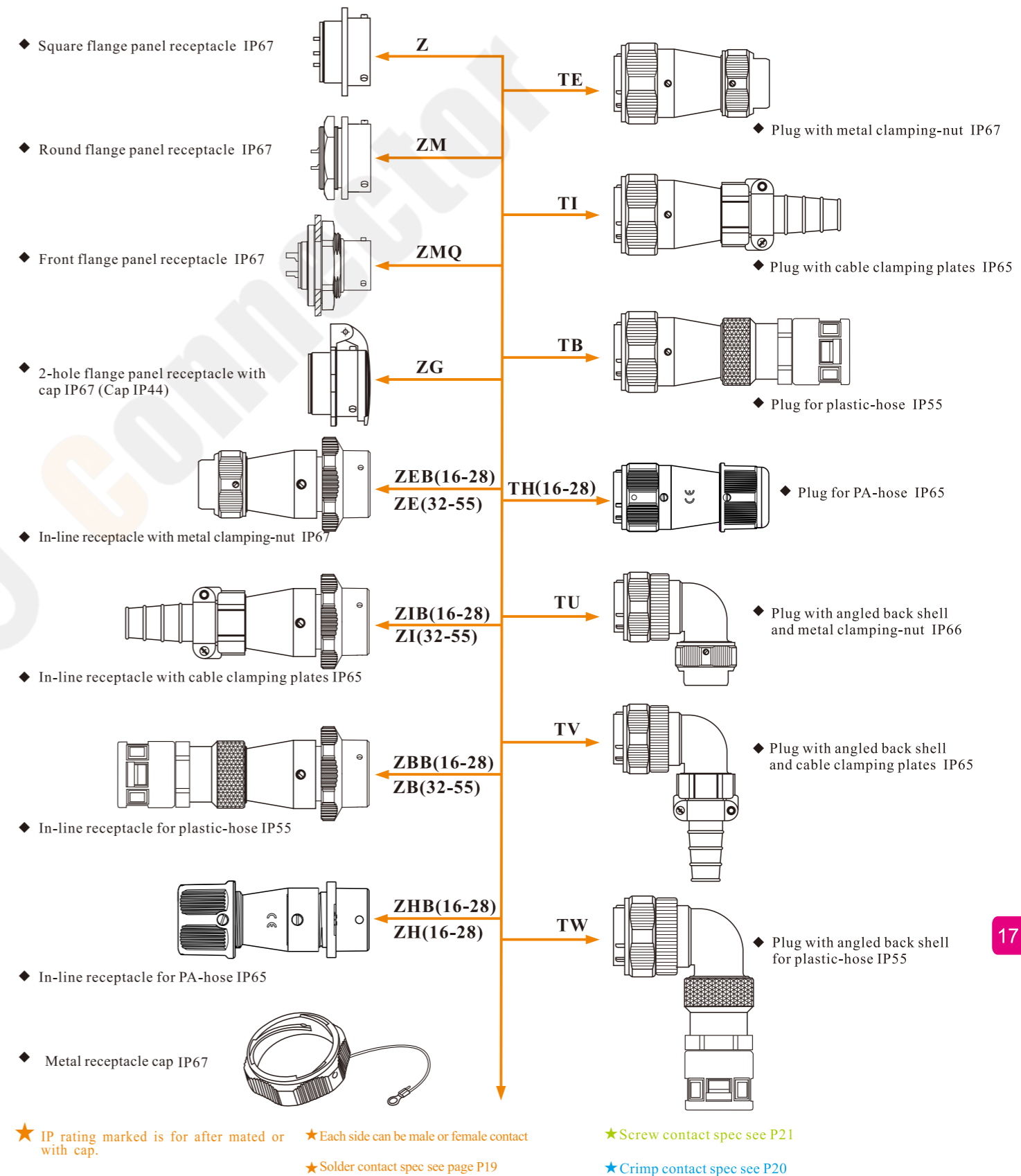

WY12 Series



WY12



Cable connector  
Mate with WY12-Z, WY12-ZM,  
WY12-ZMQ, WY12-ZE

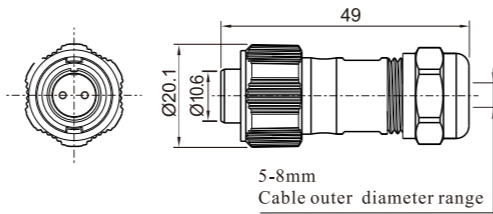

WY12J\_TE WY12K\_TE

Male contact Number of contact  
Female contact



In-line cable connector  
Mate with WY12-TE

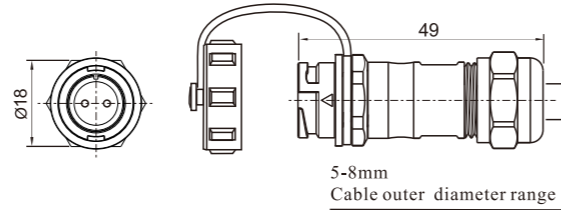

WY12J\_ZE WY12K\_ZE



Rear-nut mount  
Mate with WY12-TE

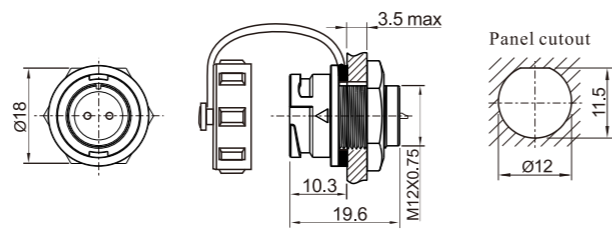

WY12J\_ZM WY12K\_ZM

Number of contact



Front-nut mount  
Mate with WY12-TE

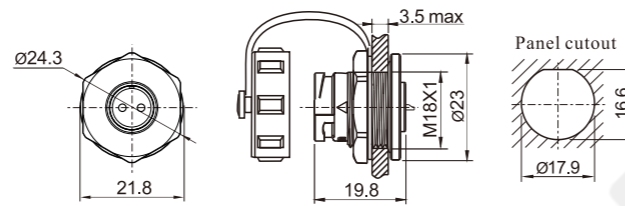

WY12J\_ZMQ WY12K\_ZMQ



Square flange  
Mate with WY12-TE

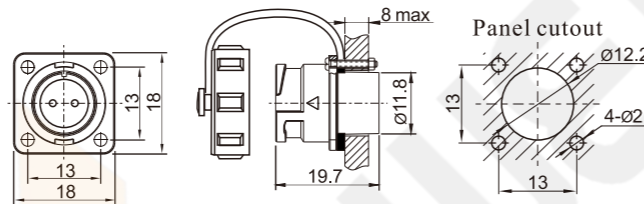

WY12J\_Z WY12K\_Z

Solder contact spec

Number of contact	2	3	4	5	6	7	9
Male contact face view							
Rated current (A)	13	13	5	5	5	5	3
Contact diameter (mm)	Ø1.6X2	Ø1.6X3	Ø1X4	Ø1X5	Ø1X6	Ø1X7	Ø0.7X9
Rated voltage (AC.V)	250	250	200	180	125	125	125
Test voltage(AC.V) 1 min	1500	1500	1500	1000	1000	1000	1000
Contact resistance (mΩ)	2	2	5	5	5	5	10
Wire size (mm <sup>2</sup> /AWG)	≤2/14	≤2/14	≤0.75/18	≤0.75/18	≤0.75/18	≤0.75/18	≤0.5/20

WY24 Series



WY24



Plug with metal clamping-nut  
Mate with WY24KRJ45Z

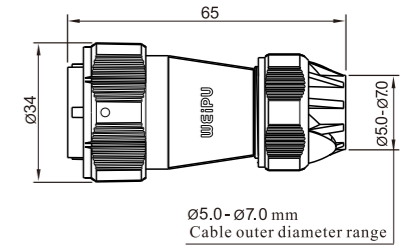

WY24JRJ45TE



Square flange receptacle  
Mate with WY24JRJ45TE

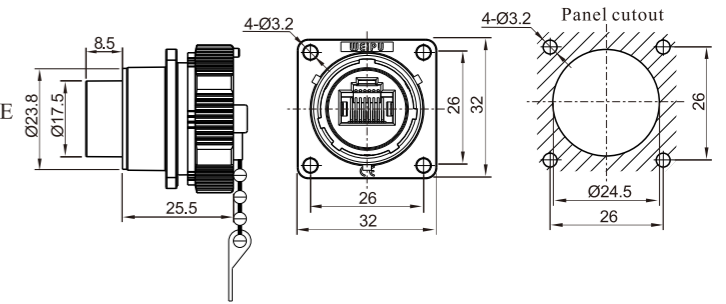

WY24KRJ45Z



Plug with metal clamping-nut  
Mate with WY24KUSB3.0Z

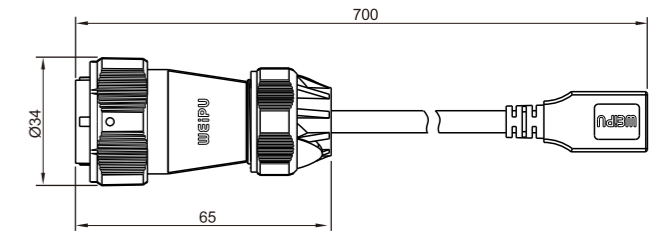

WY24JUSB3.0TE

Wire length:  
0.5m  
1.0m  
1.5m  
2.0m  
3.0m

★ Wire length can be customized



Square flange receptacle  
Mate with WY24JUSB3.0TE

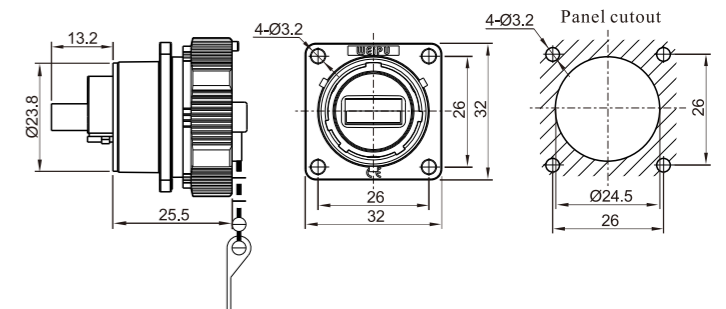

WY24KUSB3.0Z

WY24 Series



WY24



Plug with metal clamping-nut  
Mate with WY24KLCZ

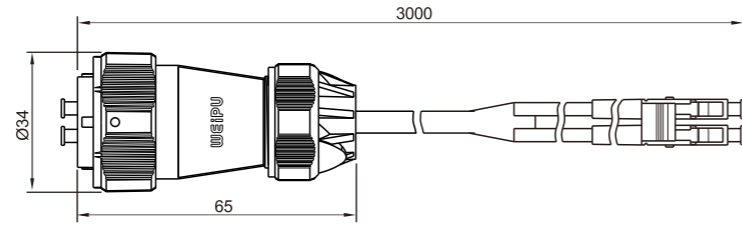

WY24JLCTE

Wire length:  
0.5m  
1.0m  
1.5m  
2.0m  
3.0m

★ Wire length can be customized



Square flange receptacle  
Mate with WY24JLCTE

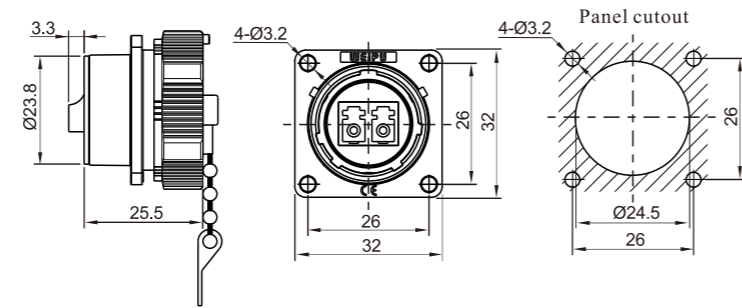

WY24KLCZ



Plug with metal clamping-nut  
Mate with WY24KHDMI2.0Z

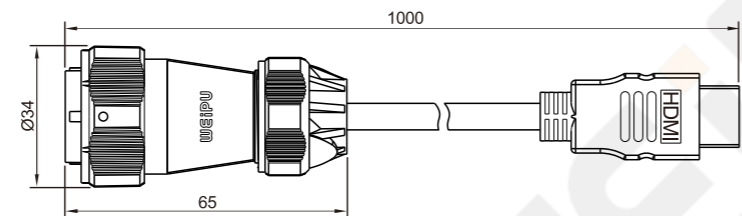

WY24JHDMI2.0TE

Wire length:  
0.5m  
1.0m  
1.5m  
2.0m  
3.0m

★ Wire length can be customized



Square flange receptacle  
Mate with WY24JHDMI2.0TE

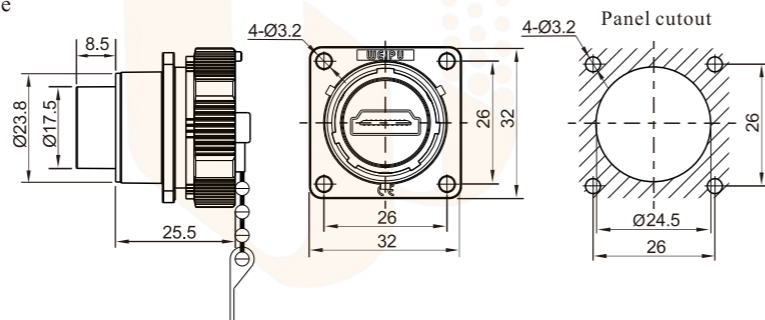

WY24KHDMI2.0Z



● Square flange panel receptacle: Z IP67

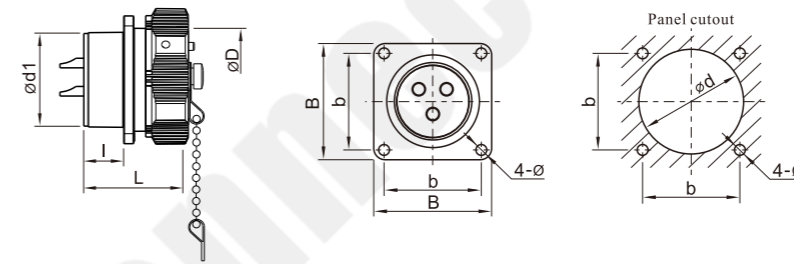

Dimension(mm)	WY16	WY20	WY24	WY28	WY32	WY40	WY48	WY55
d1	15.8	19.8	23.8	27.8	31.8	40	47.8	54.8
D	18	22	26	30	35	44	52	58
l	9.7	10	10	10	14.4	14.2	14.2	14
L	21.6	23	23	23	34	33.5	34	34
b	20	22	26	30	32	40	48	52
B	26	29	32	36	42	50	58	64
d	16.5	20.5	24.5	28.5	32.5	40.5	48.5	55.5
Ø	3.2	3.2	3.2	3.2	3.5	4.5	4.5	4.5

● Round flange panel receptacle: ZM IP67

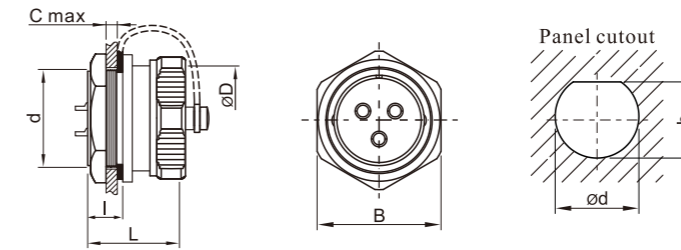

Dimension(mm)	WY16	WY20	WY24	WY28
d	M16X1	M20X1	M24X1	M28X1
D	18	22	26	30
C	5	5	5	5
l	9.7	9.9	10	10.2
L	22	23	23	23
B	21.2	25.5	29.2	33.3
Ød	15.9	19.7	23.7	27.7
h	15.3	19.3	23.2	26.9



● Front-nut-mount receptacle: ZMQ IP67

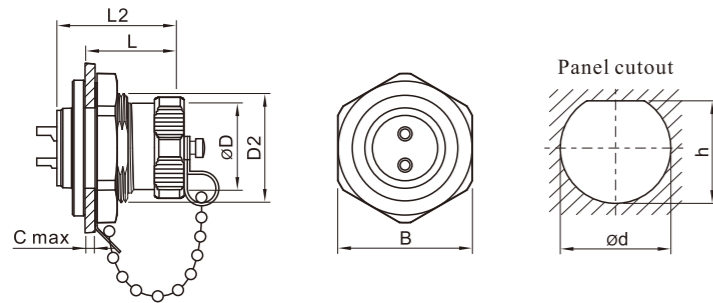

Dimension(mm)	WY16	WY20	WY24	WY28
D	18	22	26	30
D2	M22X1	M26X1	M30X1	M34X1
L	16	17	17	17
L2	21.6	23	23	23
C	5	5	5	5
B	26.8	30.8	34.8	38.8
ød	22	26	30	34
h	20.6	24.6	28.6	32.6

● 2-hole flange panel receptacle with cap: ZG IP67 (Cap IP44)

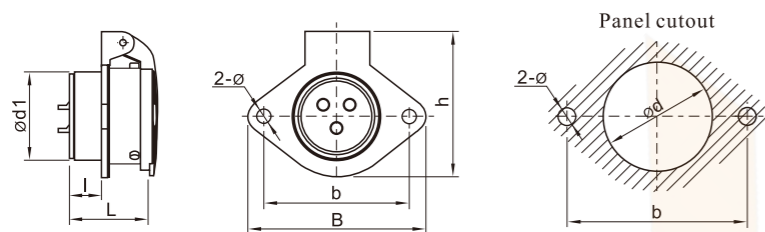

Dimension(mm)	WY16	WY20	WY24	WY28	WY32	WY40	WY48	WY55
d1	15.8	19.8	23.8	27.8	31.8	39.8	47.8	54.8
d	16.5	20.5	24.5	28.5	32.5	40.5	48.5	55.5
l	10	10	10	10	15.4	14.7	14.3	14
L	22	23	23	23	34	34	34	34
b	30	35	40	45	55	65	80	85
B	38	44	50	55	67	77	92	98
h	32.5	36.5	40.5	45.5	52.5	63.5	74.5	80
ø	3.5	4.5	4.5	4.5	5.5	5.5	5.5	6.5



● In-line receptacle with metal clamping-nut B: ZEB IP67

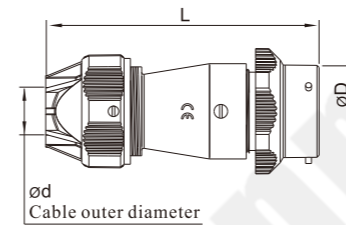

Dimension(mm)	WY16	WY20	WY24	WY28
D	18	22	26	30
L	55	63	66.5	70
ød	5-6.5	9-10.5	9-10.5	10.5-12.5

Optional cap size see P18

● In-line receptacle with metal clamping-nut: ZE IP67

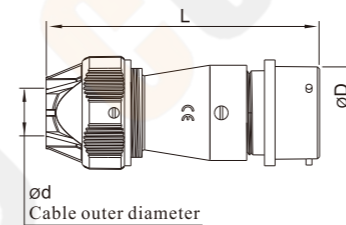

Dimension(mm)	WY32	WY40	WY48	WY55
D	35	44	52	58
L	90.5	103.5	108	131.6
ød	15.5-17	18-20	I:18-20 II:24.5-26	24.5-26

Optional cap size see P18

● Plug with metal clamping-nut: TE IP67

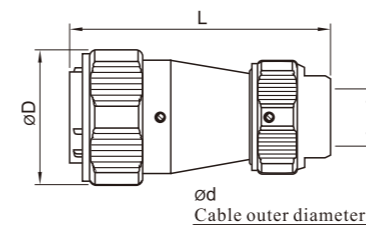

Dimension(mm)	WY16	WY20	WY24	WY28	WY32	WY40	WY48	WY55
D	25	29.5	34	38.5	44.5	54	62	68.5
L	54.5	62.5	65	68	88	100	110	131.5
ød	5-6.5	9-10.5	9-10.5	10.5-12.5	15.5-17	18-20	I:18-20 II:24.5-26	24.5-26

● Plug with angled back shell and metal clamping-nut: TU IP66

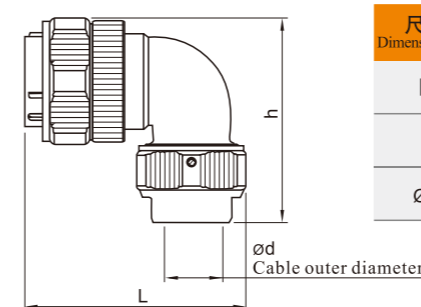

尺寸 Dimension(mm)	WY16	WY20	WY24	WY28	WY32	WY40	WY48	WY55
h	43	53	54	58	72	88	103	110.5
L	48	57	59	61	84	90	97	109
ød	5-6.5	9-10.5	9-10.5	10.5-12.5	15.5-17	18-20	24.5-26	24.5-26



● In-line receptacle with cable clamping plates B: ZIB IP65

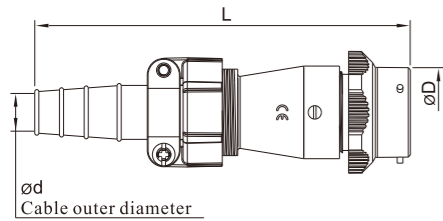

Dimension(mm)	WY16	WY20	WY24	WY28
D	18	22	26	30
L	73	88	92	101
ød	7-8	8-10.5	8-10.5	11.5-13.6

Optional cap size see P18

● In-line receptacle with cable clamping plates: ZI IP65

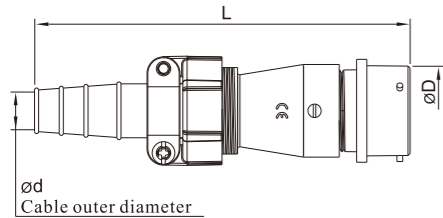

Dimension(mm)	WY32	WY40	WY48	WY55
D	35	44	52	58
L	119	130	137	165
ød	13-15.6	15.5-18.8	I:15.5-18.8 II:24-28	24-28

Optional cap size see P18

● Plug with cable clamping plates: TI IP65

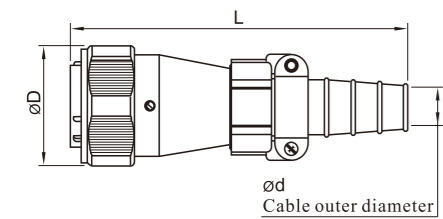

Dimension(mm)	WY16	WY20	WY24	WY28	WY32	WY40	WY48	WY55
D	25	29.5	34	38.5	44.5	54	62	68.5
L	72.5	87	92	100.5	48.5	130.5	140	163
ød	7-8	8-10.5	8-10.5	11.5-13.6	13-15.6	15.5-18.8	I:15.5-18.8 II:24-28	24-28

● Plug with angled back shell and cable clamping plates: TV IP65

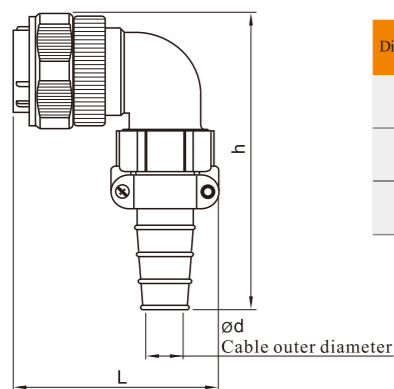

Dimension(mm)	WY16	WY20	WY24	WY28	WY32	WY40	WY48	WY55
h	60	80	80	93	103	118	137	140
L	49.5	56.5	58	61	82.5	90	98	108
ød	7-8	8-10.5	8-10.5	11.5-13.6	13-15.6	15.5-18.8	24-28	24-28



● In-line receptacle for plastic-hose B: ZBB IP55

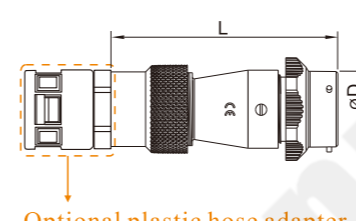

Dimension(mm)	WY16	WY20	WY24	WY28
D	18	22	26	30
L	54.5	64	67	73
Adapter size	PG7	PG11	PG11	PG16
model of plastic hose adapter	WQG-PG7(B)	WQG-PG11(B)	WQG-PG11(B)	WQG-PG16(B)
Hose size	AD10	AD15.8	AD15.8	AD21.2

Optional cap size see P18

● In-line receptacle for PA-hose: ZHB IP65

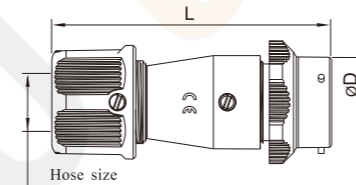

Dimension(mm)	WY16	WY20	WY24	WY28
D	18	22	26	30
L	52	62.5	66.5	70
Hose size	AD10	AD15.8	AD15.8	AD21.2

Optional cap size see P18

● In-line receptacle for plastic-hose: ZB IP55

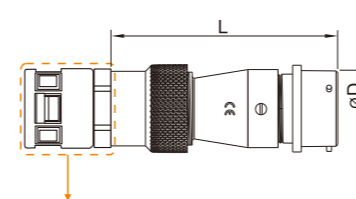

Dimension(mm)	WY32	WY40	WY48	WY55
D	35	44	52	58
L	86.5	95	104	120
Adapter size	PG21	PG29	I: PG29 II: PG36	PG36
model of plastic hose adapter	WQG-PG21(B)	WQG-PG29(B)	I: WQG-PG29(B) II: WQG-PG36(B)	WQG-PG36(B)
Hose size	AD28.5	AD34.5	I: AD34.5 II: AD42.5	AD42.5

Optional cap size see P18

● In-line receptacle for PA-hose : ZH P65

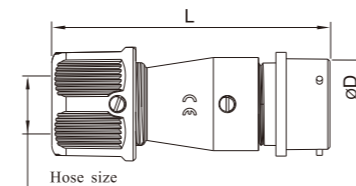

Dimension(mm)	WY16	WY20	WY24	WY28
D	18	22	26	30
L	54	64	66	70
Hose size	AD10	AD15.8	AD15.8	AD21.2

Optional cap size see P18



● Plug for plastic-hose: TB IP55

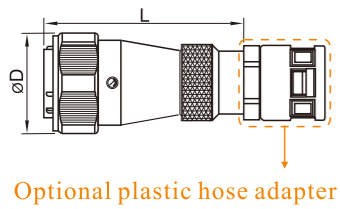

Dimension(mm)	WY16	WY20	WY24	WY28	WY32	WY40	WY48	WY55
D	25	29.5	34	38.5	44.5	54	91	96.5
L	54	62.5	66.5	72.5	87.5	95	105	118
Adapter size	PG7	PG11	PG11	PG16	PG21	PG29	I:PG29 II:PG36	PG36
model of plastic hose adapter	WQG-PG7(B)	WQG-PG11(B)	WQG-PG11(B)	WQG-PG16(B)	WQG-PG21(B)	WQG-PG29(B)	I:WQG-PG29(B) II:WQG-PG36(B)	WQG-PG36(B)
Hose size	AD10	AD15.8	AD15.8	AD21.2	AD28.5	AD34.5	I:AD34.5 II:AD42.5	AD42.5

● Plug for PA-hose: TH IP65

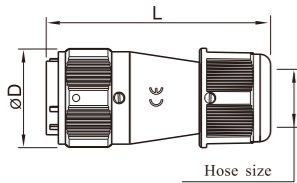

Dimension(mm)	WY16	WY20	WY24	WY28
D	25	29.6	34	38
L	51	62.5	65.5	68.5
Hose size	AD10	AD15.8	AD15.8	AD21.2

● Plug with angled back shell for plastic-hose: TW IP55

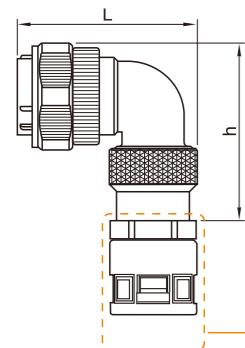

Dimension(mm)	WY16	WY20	WY24	WY28	WY32	WY40	WY48	WY55
h	44.5	53.5	55	61	70	83	91	96.5
L	47	56.5	57.5	61	82	88.5	95	106
Adapter size	PG7	PG11	PG11	PG16	PG21	PG29	PG29	PG36
model of plastic hose adapter	WQG-PG7(B)	WQG-PG11(B)	WQG-PG11(B)	WQG-PG16(B)	WQG-PG21(B)	WQG-PG29(B)	WQG-PG29(B)	WQG-PG36(B)
Hose size	AD10	AD15.8	AD15.8	AD21.2	AD28.5	AD34.5	AD42.5	AD42.5



● Plug with strain relief: TX IP67

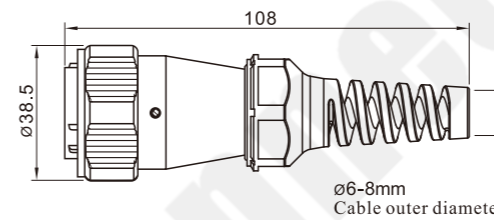

● In-line receptacle with strain relief B: ZXB IP67

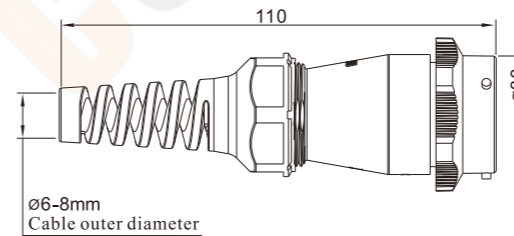

★ It can be produced 28 modle, other models are customizable

Solder contact spec

★Crimp contact spec see P20

★Screw contact spec see P21

WY28	2	3	4	7	8	8B	9	10	10B	12	16	17	20	24	26	35
Male contact face view																
Rated current (A)	50	50	25	25	25	60.5	25.5	25	10	10	10	10	5	5	5	5
Contact diameter(mm)	Ø3.5X2	Ø3.5X3	Ø2.5X4	Ø2.5X7	Ø2.5X8	Ø5X2 Ø1X6	Ø2.5X4 Ø1X5	Ø2.5X10	Ø1.5X10	Ø1.5X12	Ø1.5X16	Ø1.5X17	Ø1X20	Ø1X24	Ø1X26	Ø1X35
Rated voltage (AC.V)	500	500	500	500	500	500 400	500	500	500	500	500	500	400	400	400	400
Test voltage(AC.V) 1 min	1500	1500	1500	1500	1500	1500	1500	1500	1500	1500	1500	1500	1200	1200	1200	1200
Contact resistance(mΩ)	0.5	0.5	1	1	1	0.5, 5	1, 5	1	2.5	2.5	2.5	2.5	5	5	5	5
Termination	solder / screw	solder / screw	solder / screw	solder / screw	solder / screw	solder	solder	solder / screw	solder	solder	solder	solder	solder	solder	solder	solder
Wire size (mm <sup>2</sup> / AWG)	≤10/7	≤10/7	≤4/11	≤4/11	≤4/11	≤16/5 ≤0.75/18	≤4/11 ≤0.75/18	≤4/11	≤2/14	≤2/14	≤2/14	≤2/14	≤2/14	≤0.75/18	≤0.75/18	≤0.75/18
Wire size for screw termination	≤6/10	≤6/10	≤1.5/15	≤1.5/15	≤1.5/15	/	/	≤1.5/15	/	/	/	/	/	/	/	/

Solder contact spec

WS16, WF16, WY16	2	3	4	2B	3B	4B	5	7	9	10
Male contact face view										
Rated current (A)	10	10	5	15	15	15	5	5	5	5
Contact diameter(mm)	Ø1.5X2	Ø1.5X3	Ø1X4	Ø2X2	Ø2X3	Ø2X4	Ø1X5	Ø1X7	Ø1X9	Ø1X10
Rated voltage (AC.V)	500	500	500	500	500	500	500	400	400	400
Test voltage(AC.V) 1 min	1500	1500	1500	1500	1500	1500	1500	1200	1200	1200
Contact resistance(mΩ)	2.5	2.5	5	2.5	2.5	2.5	5	5	5	5
Insulation resistance (MΩ)	2000	2000	2000	2000	2000	2000	2000	2000	2000	2000
Wire size(mm <sup>2</sup> /AWG)	≤2/14	≤2/14	≤0.75/18	≤2/14	≤2/14	≤2/14	≤0.75/18	≤0.75/18	≤0.75/18	≤0.75/18

WS20, WF20, WY20	2	3	4	5	6	6B	7	8	9	12	15
Male contact face view											
Rated current (A)	25	25	25	10	5 25	5 30	10	10	5	5	5
Contact diameter(mm)	Ø2.5X2	Ø2.5X3	Ø2.5X4	Ø1.5X5	Ø1X2 Ø2.5X4	Ø1X4 Ø3X2	Ø1.5X7	Ø1.5X8	Ø1X9	Ø1X12	Ø1X15
Rated voltage (AC.V)	500	500	500	500	500	500	500	500	400	400	400
Test voltage(AC.V) 1 min	1500	1500	1500	1500	1500	1500	1500	1500	1200	1200	1200
Contact resistance(mΩ)	1	1	1	2.5	5 1	5 1	2.5	2.5	5	5	5
Insulation resistance (MΩ)	2000	2000	2000	2000	2000	2000	2000	2000	2000	2000	2000
Wire size(mm <sup>2</sup> /AWG)	≤4/11	≤4/11	≤4/11	≤2/14	≤0.75/18 ≤4/11	≤0.75/18 ≤4/11	≤2/14	≤2/14	≤0.75/18	≤0.75/18	≤0.75/18

WS24, WF24, WY24	2	3	4	9	10	12	12B	19
Male contact face view								
Rated current (A)	25	25	25	5 25	10	10	5 30	5
Contact diameter(mm)	Ø2.5X2	Ø2.5X3	Ø2.5X4	Ø1X5 Ø2.5X4	Ø1.5X10	Ø1.5X12	Ø1X9 Ø3X3	Ø1X19
Rated voltage (AC.V)	500	500	500	500	500	500	500	400
Test voltage(AC.V) 1 min	1500	1500	1500	1500	1500	1500	1500	1200
Contact resistance(mΩ)	1	1	1	5 1	2.5	2.5	5 1	5
Insulation resistance (MΩ)	2000	2000	2000	2000	2000	2000	2000	2000
Wire size(mm <sup>2</sup> /AWG)	≤4/11	≤4/11	≤4/11	≤0.75/18 ≤4/11	≤2/14	≤2/14	≤0.75/18 ≤4/11	≤0.75/18

WS28, WF28, WY28	2	3	4	7	8	8B	9	10	10B	12	16	17	20	24	26	35
Male contact face view																
Rated current (A)	50	50	25	25	25	60.5	25.5	25	10	10	10	10	5	5	5	5
Contact diameter(mm)	Ø3.5X2	Ø3.5X3	Ø2.5X4	Ø2.5X7	Ø2.5X8	Ø5X2 Ø1X6	Ø2.5X4 Ø1X5	Ø2.5X10	Ø1.5X10	Ø1.5X12	Ø1.5X16	Ø1.5X17	Ø1X20	Ø1X24	Ø1X26	Ø1X35
Rated voltage (AC.V)	500	500	500	500	500	500 400	500	500	500	500	500	500	400	400	400	400
Test voltage(AC.V) 1 min	1500	1500	1500	1500	1500	1500	1500	1500	1500	1500	1500	1500	1200	1200	1200	1200
Contact resistance(mΩ)	0.5	0.5	1	1	1	0.5.5	1.5	1	2.5	2.5	2.5	2.5	5	5	5	5
Insulation resistance (MΩ)	2000	2000	2000	2000	2000	2000	2000	2000	2000	2000	2000	2000	2000	2000	2000	2000
Wire size(mm <sup>2</sup> /AWG)	≤10/7	≤10/7	≤4/11	≤4/11	≤4/11	≤16/5 ≤0.75/18	≤4/11 ≤0.75/18	≤4/11	≤2/14	≤2/14	≤2/14	≤2/14	≤0.75/18	≤0.75/18	≤0.75/18	≤0.75/18

Solder contact spec

WS32, WF32, WY32	4	6	8	8B	10	10B	11	12	13	19
Male contact face view										
Rated current (A)	50	10 50	10 50	10 50	10 25	25	25	25	10 25	10
Contact diameter(mm)	Ø3.5X4	Ø1.5X2 Ø3.5X4	Ø1.5X5 Ø3.5X3	Ø1.5X4 Ø3.5X4	Ø1.5X5 Ø2.5X5	Ø2.5X10	Ø2.5X11	Ø2.5X12	Ø1.5X9 Ø2.5X4	Ø1.5X19
Rated voltage (AC.V)	500V	500V	500V	500V	500V	500V	500V	500V	500V	500V
Test voltage(AC.V) 1 min	1500V	1500V	1500V	1500V	1500V	1500V	1500V	1500V	1500V	1500V
Contact resistance(mΩ)	0.5	2.5 0.5	2.5 0.5	2.5 0.5	2.5 1	1	1	1	2.5 1	2.5
Insulation resistance (MΩ)	2000	2000	2000	2000	2000	2000	2000	2000	2000	2000
Wire size(mm <sup>2</sup> /AWG)	≤10/7	≤2/14 ≤10/7	≤2/14 ≤10/7	≤2/14 ≤10/7	≤2/14 ≤4/11	≤4/11	≤4/11	≤4/11	≤2/14 ≤4/11	≤2/14

WS40, WF40, WY40	5	9	15	26	31	52
Male contact face view						
Rated current (A)	50	25 50	10	10 25	10	5
Contact diameter(mm)	Ø3.5X5	Ø2.5X5 Ø3.5X4	Ø1.5X15	Ø1.5X22 Ø2.5X4	Ø1.5X31	Ø1X52
Rated voltage (AC.V)	500	500	500	500	500	400
Test voltage(AC.V) 1 min	1500	1500	1500	1500	1500	1200
Contact resistance(mΩ)	0.5	1 0.5	2.5	2.5.1	2.5	5
Insulation resistance (MΩ)	2000	2000	2000	2000	2000	2000
Wire size(mm <sup>2</sup> /AWG)	≤10/7	≤4/11 ≤10/7	≤2/14	≤2/14 ≤4/11	≤2/14	≤0.75/18

WS48, WF48, WY48	5	7	20	27	38	42
Male contact face view						
Rated current (A)	100	50	25	10 25	10 25	10
Contact diameter(mm)	Ø5.5X5	Ø3.5X7	Ø2.5X20	Ø1.5X26 Ø2.5X1	Ø1.5X33 Ø2.5X5	Ø1.5X42
Rated voltage (AC.V)	500	500	500	500	500	500
Test voltage(AC.V) 1 min	1500	1500	1500	1500	1500	1500
Contact resistance(mΩ)	0.3	0.5	1	2.5.1	2.5.1	2.5
Insulation resistance (MΩ)	2000	2000	2000	2000	2000	2000
Wire size(mm <sup>2</sup> /AWG)	≤25/3	≤10/7	≤4/11	≤2/14 ≤4/11	≤2/14 ≤4/11	≤2/14

WS55, WF55, WY55	4	7	40	53	61
Male contact face view					
Rated current (A)	50 150	50 100	10 25	10 25	10
Contact diameter(mm)	Ø3.5X1 Ø10X3	Ø3.5X1 Ø5.5X6	Ø1.5X25 Ø2.5X15	Ø1.5X48 Ø2.5X5	Ø1.5X61
Rated voltage (AC.V)	500	500	500	500	500
Test voltage(AC.V) 1 min	1500	1500	1500	1500	1500
Contact resistance(mΩ)	0.5 0.2	0.5 0.3	2.5 1	2.5 1	2.5
Insulation resistance (MΩ)	2000	2000	2000	2000	2000
Wire size(mm <sup>2</sup> /AWG)	≤10/7 ≤70/(2/0)	≤10/7 ≤25/3	≤2/14 ≤4/11	≤2/14 ≤4/11	≤2/14