

## PLCC Series

# 3528 0.2W Single Color

## Datasheet - AM



Automotive Lighting



Outdoor Lighting



General Lighting



Indoor Lighting



Signal Lighting

### Introduction :

Ultra high luminous efficacy, combined with the flexibility in design due to its slim and miniature size, PLCC LED Series are optimized to be used as lighting for automotive signal lighting designs or signboard.

### Description :

- Automotive lighting interior and exterior
- Signal and Symbol Luminaire
- Best luminous and color uniformity
- Enables halogen and CDM replacement
- The article itself presents the actual color.

### Feature and Benefits :

- High luminous Intensity and high efficiency
- Based on Red : AlGaInP technology
- Wide viewing angle : 120°
- Excellent performance and visibility
- Suitable for all SMT assembly methods
- IR reflow process compatible
- Environmental friendly; RoHS compliance
- Qualification according to AEC-Q101 rev. D

## Table of Contents

---

|   |    |
|---|----|
| General Information .....                   | 3  |
| Absolute Maximum Ratings .....              | 4  |
| Characteristics .....                       | 4  |
| Luminous Flux Characteristic.....           | 5  |
| Voltage Bin Structure .....                 | 5  |
| Wavelength Bin Structure .....              | 5  |
| Mechanical Dimensions .....                 | 6  |
| Characteristic curve.....                   | 7  |
| Reflow Profile .....                        | 12 |
| Reliability.....                            | 13 |
| Product Packaging Information (Red) .....   | 14 |
| Product Packaging Information (Yellow)..... | 15 |
| Revision History .....                      | 16 |
| About Edison Opto .....                     | 16 |

## General Information

### Ordering Code Format

2      T      03      X2      xX      X      00      03      xxx  
 X1      X2      X3-X4      X5-X6      X7-X8      X9      X10-X11      X12-X13      X14-X16

| X1   |         | X2        |      | X3-X4  |      | X5-X6   |      | X7-X8     |        |
|------|---------|-----------|------|--------|------|---------|------|-----------|--------|
| Type |         | Component |      | Series |      | Wattage |      | Color/CCT |        |
| 2    | Emitter | T         | PLCC | 03     | 3528 | X2      | 0.2W | RX        | Red    |
|      |         |           |      |        |      |         |      | YX        | Yellow |

| X9  |              | X10-X11 |   | X12-X13 |    | X14-X16       |   |
|-----|--------------|---------|---|---------|----|---------------|---|
| BIN |              | CRI     |   | Voltage |    | Serial Number |   |
| X   | Single Color | 00      | - | 03      | 3V | -             | - |

## Absolute Maximum Ratings

Absolute maximum ratings ( $T_a=25^{\circ}\text{C}$ )

| Parameter  | Symbol             | Value  | Units              |
|--|--------------------|--|--------------------|
| DC Forward Current   | $I_F$              | 70   | mA                 |
| Pulse Forward Current ( $t_p \leq 100\mu\text{s}$ , Duty cycle=0.25) | $I_{\text{pulse}}$ | 100  | mA                 |
| Reverse Voltage  | $V_R$              | 12   | V                  |
| LED Junction Temperature   | $T_J$              | 125  | $^{\circ}\text{C}$ |
| Operating Temperature  | -                  | -40 ~ +85  | $^{\circ}\text{C}$ |
| Storage Temperature  | -                  | -40 ~ +125   | $^{\circ}\text{C}$ |
| ESD Sensitivity (HBM)  | $V_B$              | 2,000  | V                  |
| Soldering Temperature  | $T_s$              | Reflow Soldering : 255~260 $^{\circ}\text{C}$ /10~30sec<br>Manual Soldering : 350 $^{\circ}\text{C}$ /3sec |                    |

Note:

$I_{\text{pulse}}$  condition: pulse width  $\leq 0.1\text{msec}$  and duty  $\leq 1/10$ .

## Characteristics

| Parameter                  | Symbol                 | Value  | Units  |
|----------------------------|------------------------|--|--------|
| Viewing Angle              | (Typ.) $2\theta_{1/2}$ | 120  | Degree |
| Wavelength                 | (Red)<br>(Yellow)      | 620-630<br>585-595   | nm     |
| JEDEC Moisture Sensitivity | -                      | Level 2a<br><b>Floor Life</b><br>Conditions: $\leq 30^{\circ}\text{C}$ / 60% RH<br><b>Soak Requirements(Standard)</b><br>Time (hours): 120+1/-0<br>Conditions: $60^{\circ}\text{C}$ / 60% RH |        |

Notes:

$2\theta_{1/2}$  is the off-axis angle where the luminous intensity is half of the axial luminous intensity.

2. Edison Opto maintains a tolerance of  $\pm 1\text{nm}$  for dominant wavelength.

## Luminous Flux Characteristic

Luminous Flux Characteristics Tj=25°C

| Color  | Group | Min Luminous Intensity (mcd) | Max Luminous Intensity (mcd) | Forward Current (mA) | Order Code       |
|--------|-------|------------------------------|------------------------------|----------------------|------------------|
| Red    | H0    | 3200                         | 3650                         | 70                   | 2T03X2RXX00030A1 |
|        | I0    | 3650                         | 4150                         |                      |                  |
| Yellow | I0    | 3650                         | 4150                         |                      | 2T03X2YXX00030A1 |
|        | J0    | 4150                         | 4700                         |                      |                  |

Note:

The luminous flux performance is guaranteed within published operating conditions. Edison Opto maintains a tolerance of  $\pm 10\%$  on flux measurements.

## Voltage Bin Structure

| Group | Min. Voltage (V) | Max. Voltage (V) |
|-------|------------------|------------------|
| U04   | 1.9              | 2.2              |
| U05   | 2.2              | 2.5              |
| V00   | 2.5              | 2.8              |
| V01   | 2.8              | 3.1              |
| V02   | 3.1              | 3.4              |

Note:

Forward voltage measurement allowance is  $\pm 0.06V$ .

## Wavelength Bin Structure

| Color  | Group | Min. Wd (nm) | Max. Wd (nm) |
|--------|-------|--------------|--------------|
| Red    | RX0   | 620          | 630          |
| Yellow | YW0   | 585          | 588          |
|        | YX0   | 588          | 591          |
|        | YY0   | 591          | 595          |

Note:

Dominant wavelength measurement allowance is  $\pm 1nm$ .

## Mechanical Dimensions

### Emitter Type Dimension

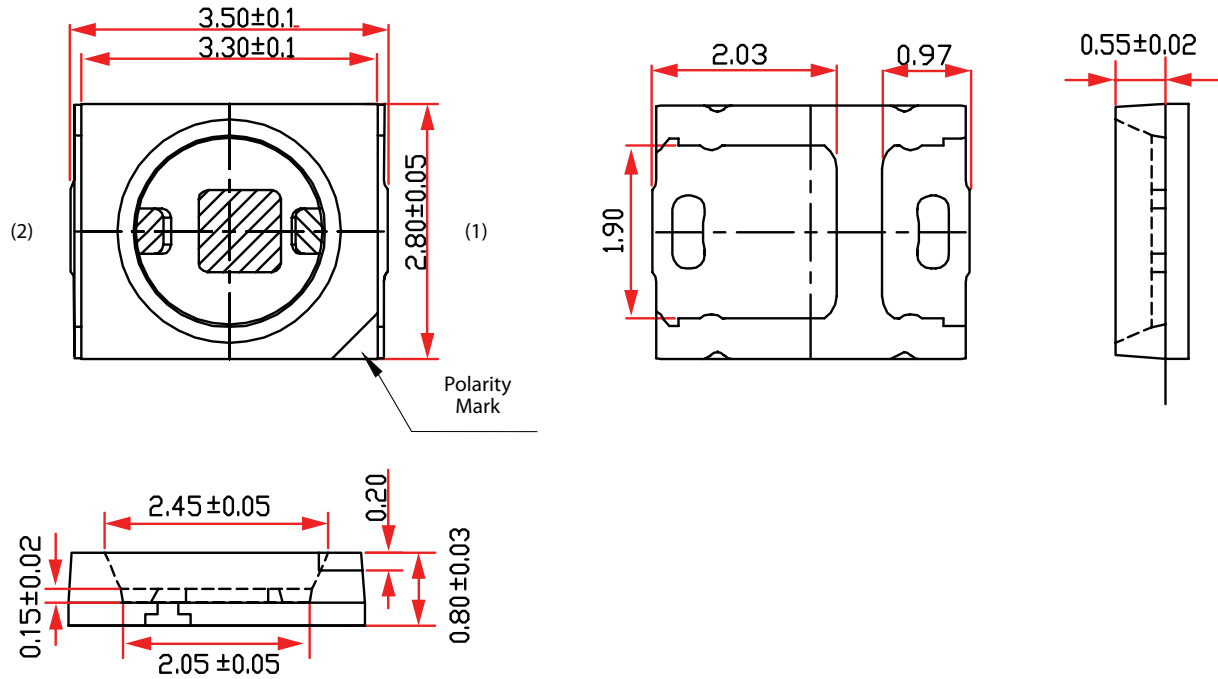

### Circuit

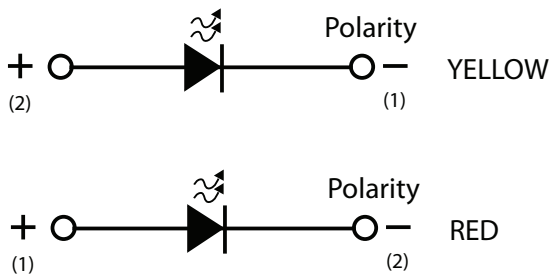

### Solder Pad

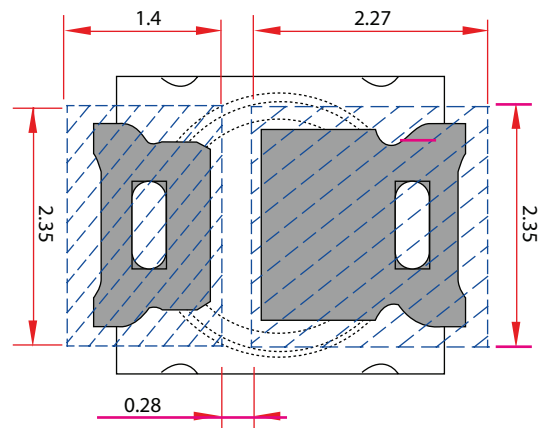

#### Notes:

1. All dimensions are measured in mm.
2. Tolerance :  $\pm 0.2$  mm

## Characteristic curve

### Color Spectrum

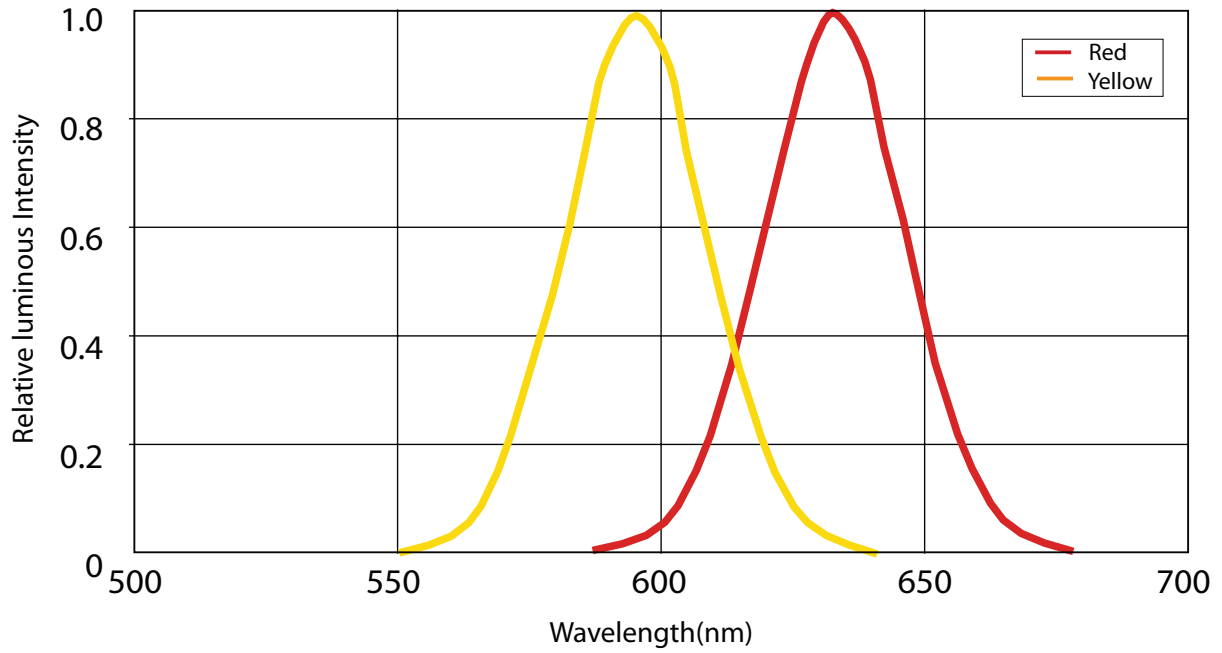

### Beam Pattern

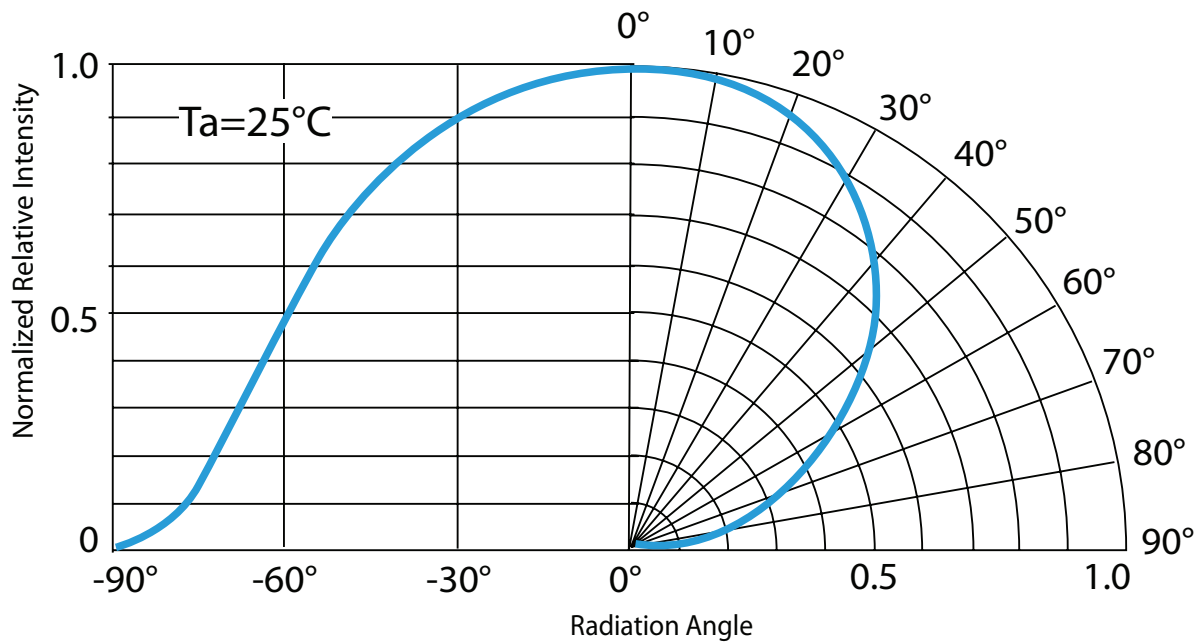

### Forward Current vs. Forward Voltage

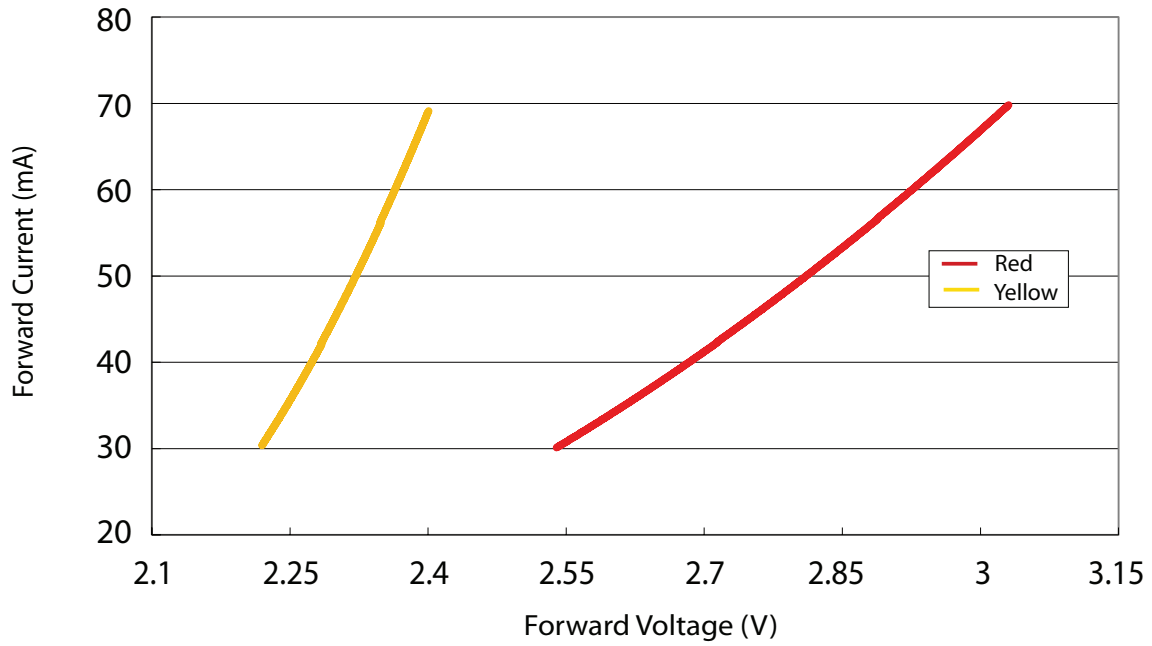

### Relative luminous Intensity vs. Forward Current

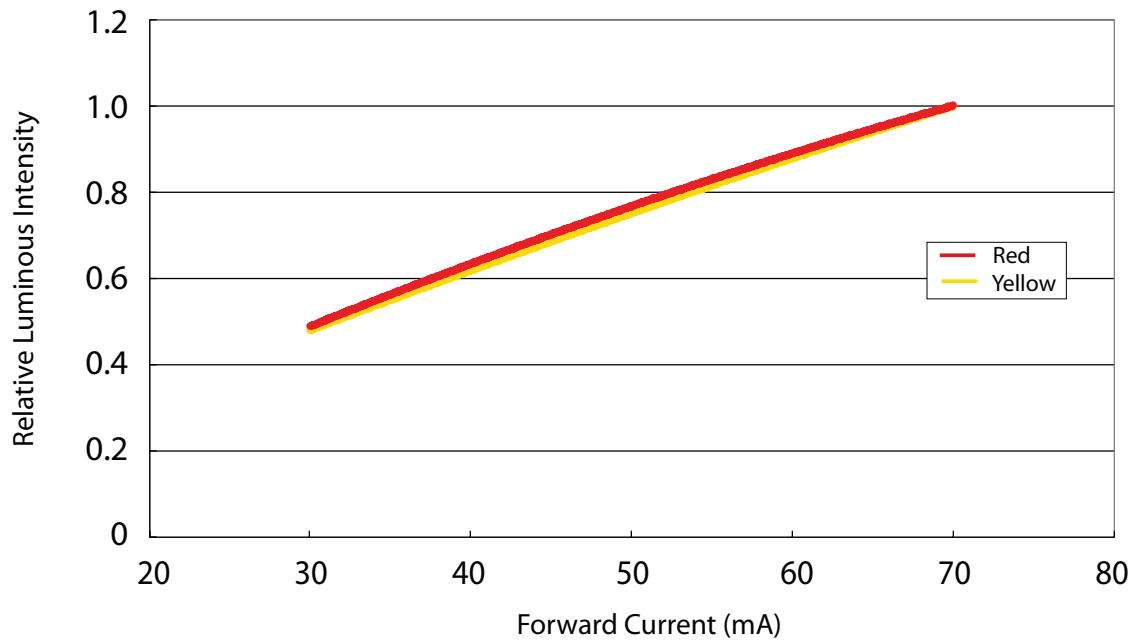

### Relative Luminous Flux vs. Junction Temperature

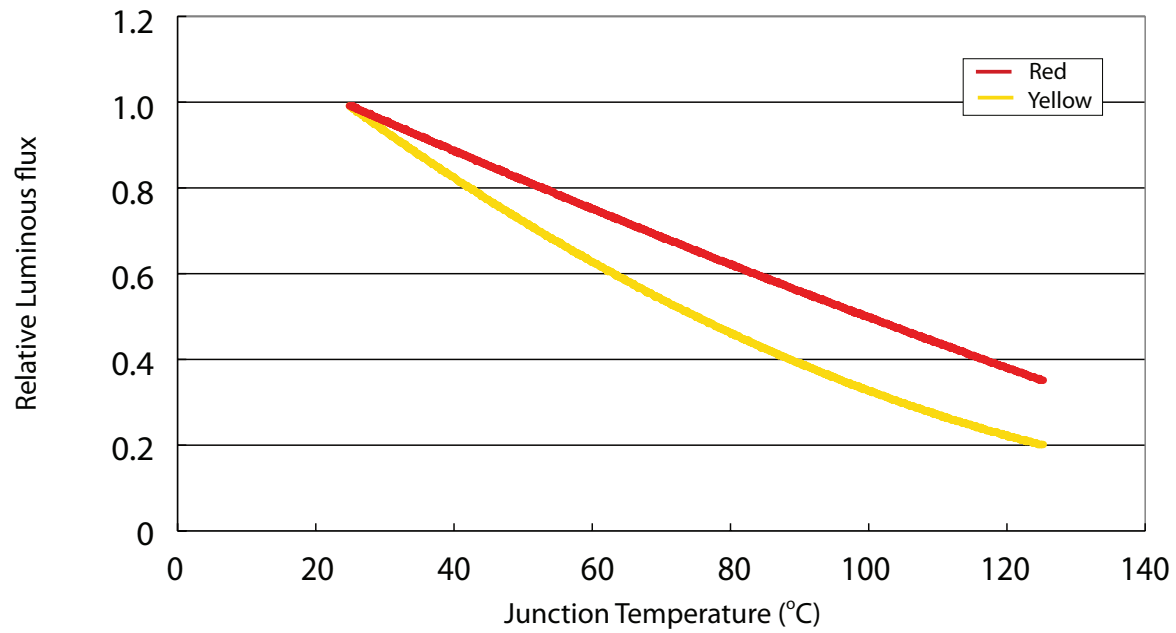

### Forward Voltage vs. Junction Temperature

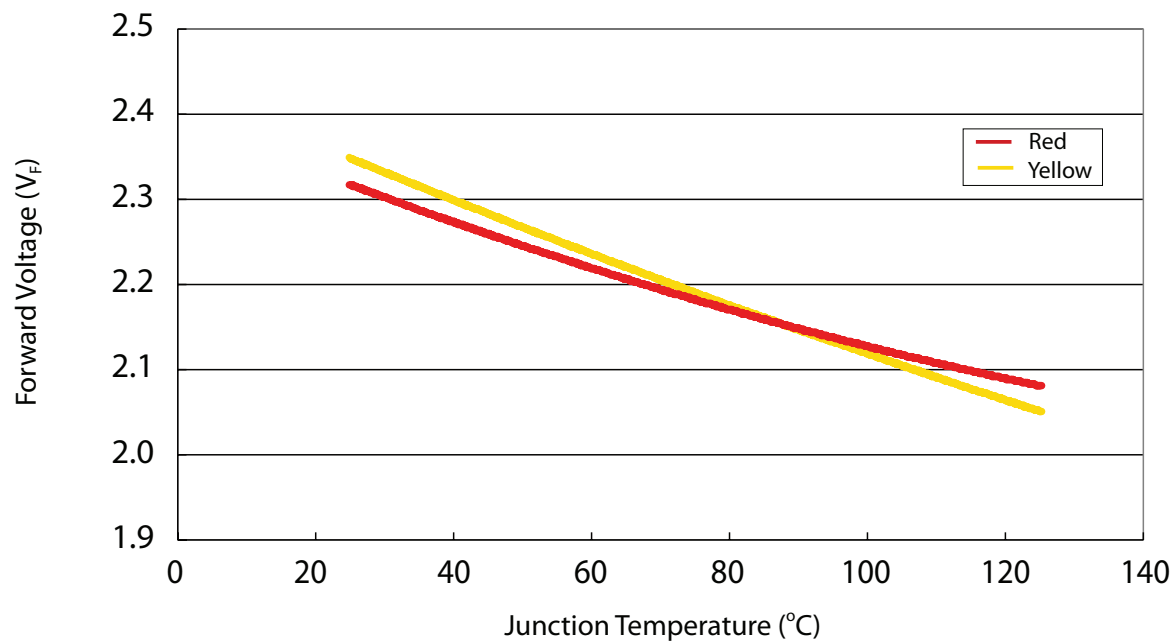

### Wavelength vs. Forward Current

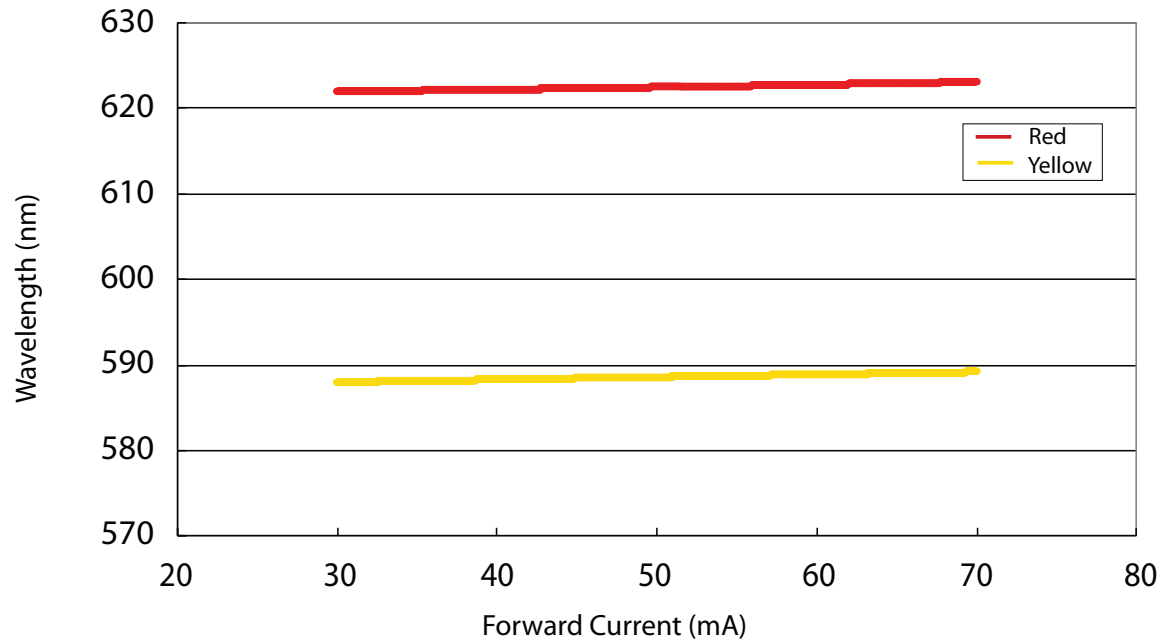

### Wavelength vs. Junction temperature

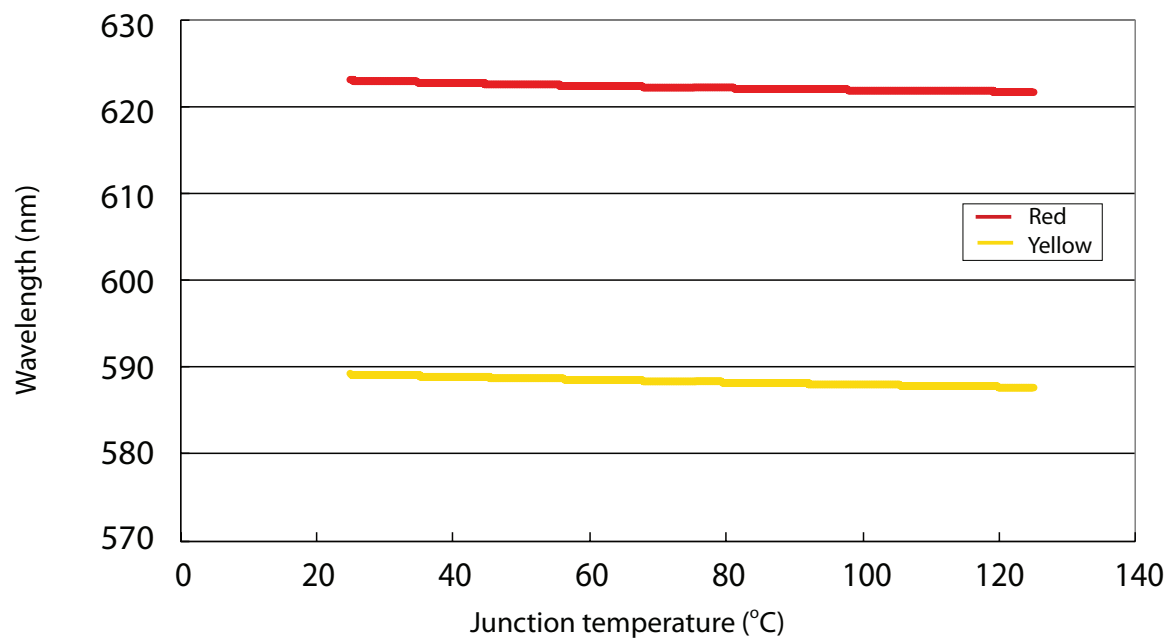

### Maximum Current vs. Ambient Temperature

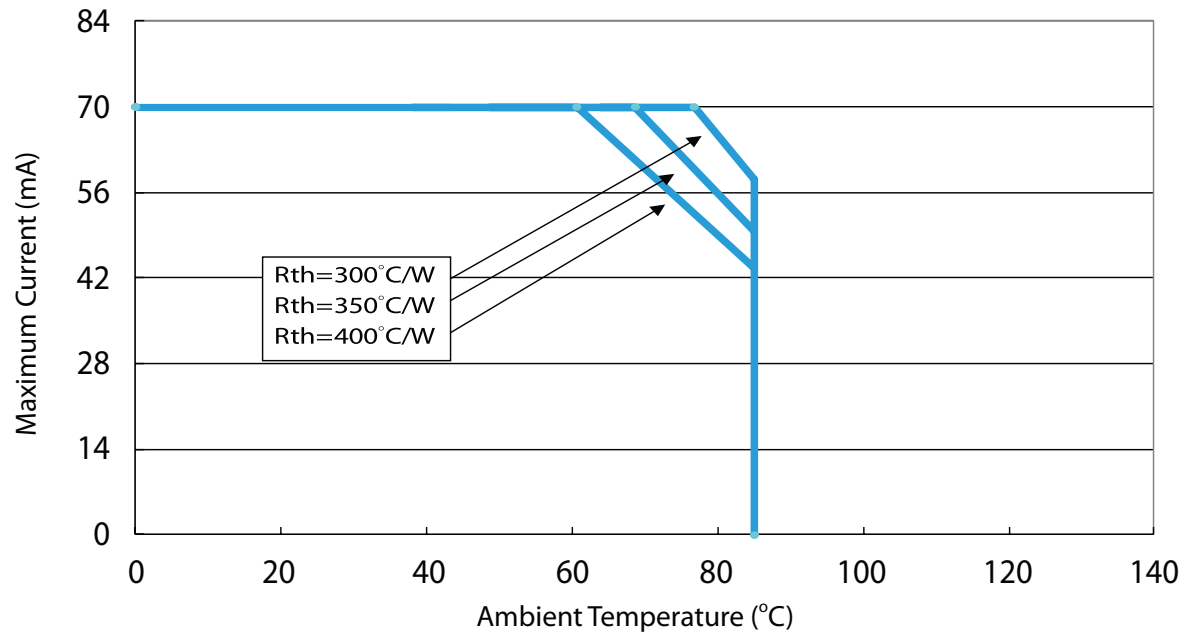

## Reflow Profile

The following reflow profile is from IPC/JEDEC J-STD-020D which provided here for reference.

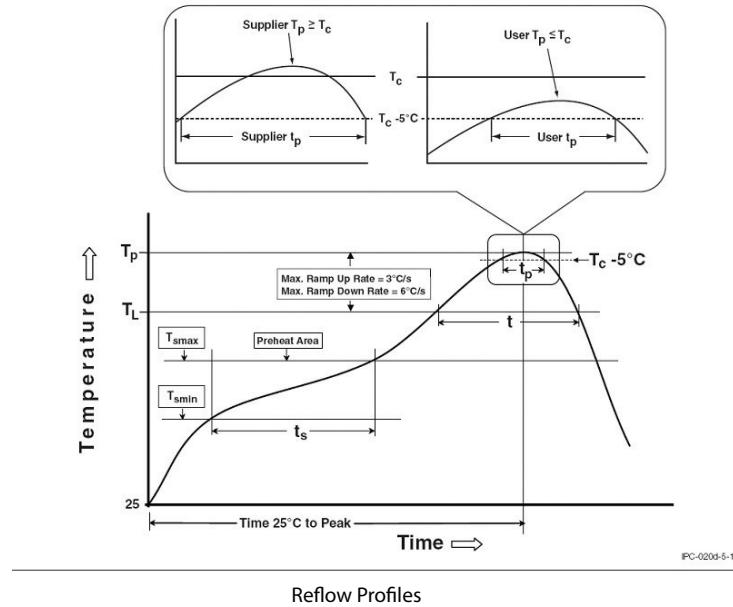

Reflow Profiles

### Classification Reflow Profiles

| Profile Feature  | Pb-Free Assembly |
|--|------------------|
| Preheat & Soak   |                  |
| Temperature min ( $T_{smin}$ )   | 150 °C           |
| Temperature max ( $T_{smax}$ )   | 200 °C           |
| Time ( $T_{smin}$ to $T_{smax}$ ) ( $t_s$ )  | 60-120 seconds   |
| Average ramp-up rate ( $T_{smax}$ to $T_p$ )                                       | 3 °C/second max. |
| Liquidous temperature ( $T_L$ )  | 217 °C           |
| Time at liquidous ( $t_L$ )  | 60-150 seconds   |
| Peak package body temperature ( $T_p$ )*   | 255 °C ~260 °C * |
| Classification temperature ( $T_c$ )   | 260 °C           |
| Time ( $t_p$ )** within 5 °C of the specified classification temperature ( $T_c$ ) | 30** seconds     |
| Average ramp-down rate ( $T_p$ to $T_{smax}$ )                                     | 6°C/second max.  |
| Time 25°C to peak temperature  | 8 minutes max.   |

Notes:

- \* Tolerance for peak profile temperature ( $T_p$ ) is defined as a supplier minimum and a user maximum.
- \*\* Tolerance for time at peak profile temperature ( $t_p$ ) is defined as a supplier minimum and a user maximum.

## Reliability

| NO . | Test Item                               | Test Condition                       | Remark     |
|------|---|--------------------------------------|------------|
| 1    | Temperature Cycle                       | -40°C~100°C<br>30, 30, mins          | 100 Cycle  |
| 2    | Thermal Shock                           | -40°C~100°C<br>15, 15 mins ≤ 10 sec  | 100 Cycle  |
| 3    | Resistance to Soldering Heat            | T <sub>SOL</sub> =260°C, 30 sec      | 3 times    |
| 4    | Moisture Resistance                     | 25°C~65°C 90% RH<br>24 hrs / 1 cycle | 10 Cycle   |
| 5    | High-Temperature Storage                | T <sub>A</sub> =100°C                | 1,000 hrs  |
| 6    | Humidity Heat Storage                   | T <sub>A</sub> =85°C<br>RH=85%       | 1,000 hrs  |
| 7    | Low-Temperature Storage                 | T <sub>A</sub> =-40°C                | 1,000 hrs  |
| 8    | Operation Life test                     | 25°C                                 | 1,000 hrs  |
| 9    | High Temperature<br>Operation Life test | 85°C                                 | 1,000 hrs  |
| 10   | High Humidity Heat Life Test            | 85°C, 85%RH                          | 1,000 hrs  |
| 11   | ON/OFF Test                             | 30 sec ON, 30 sec OFF                | 1.5W times |

## Failure Criteria

| Item                            | Criteria for Judgment          |                    |
|---------------------------------|--------------------------------|--------------------|
|                                 | Min.                           | Max.               |
| Lumen Maintenance               | 85%                            | -                  |
| $\Delta u'v'$                   | -                              | 0.006              |
| Forward Voltage                 | -                              | Initial Data x 1.1 |
| Reverse Current                 | -                              | 10 $\mu$ A         |
| Resistance to<br>Soldering Heat | No dead lamps or visual damage |                    |

## Product Packaging Information (Red)

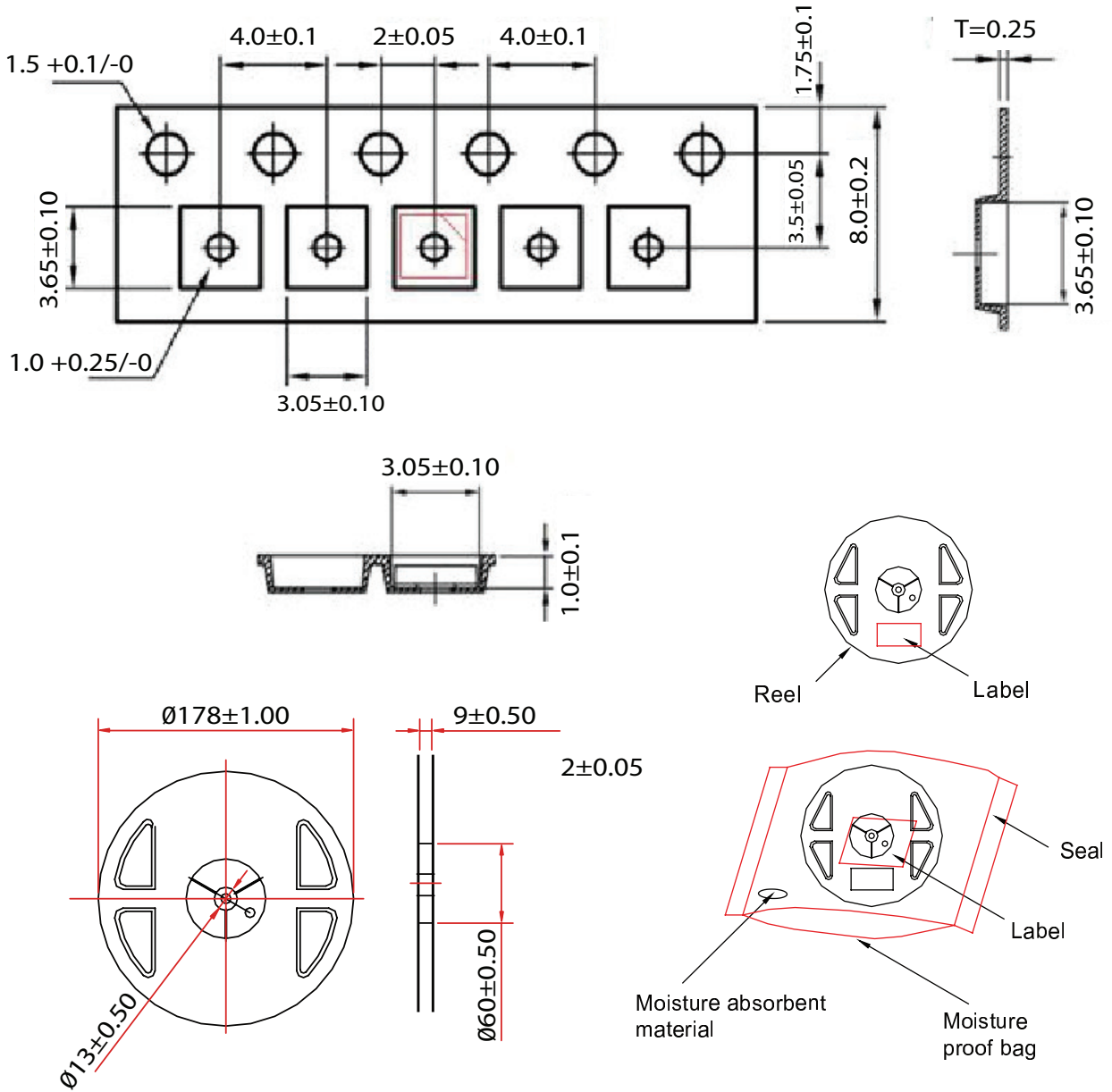

| Item   | Quantity | Total    | Dimensions(mm) |
|--|----------|----------|----------------|
| Reel   | 4,000pcs | 4,000pcs | R=178          |
| Starting with 150pcs empty, and 150pcs empty at the last |          |          |                |

## Product Packaging Information (Yellow)

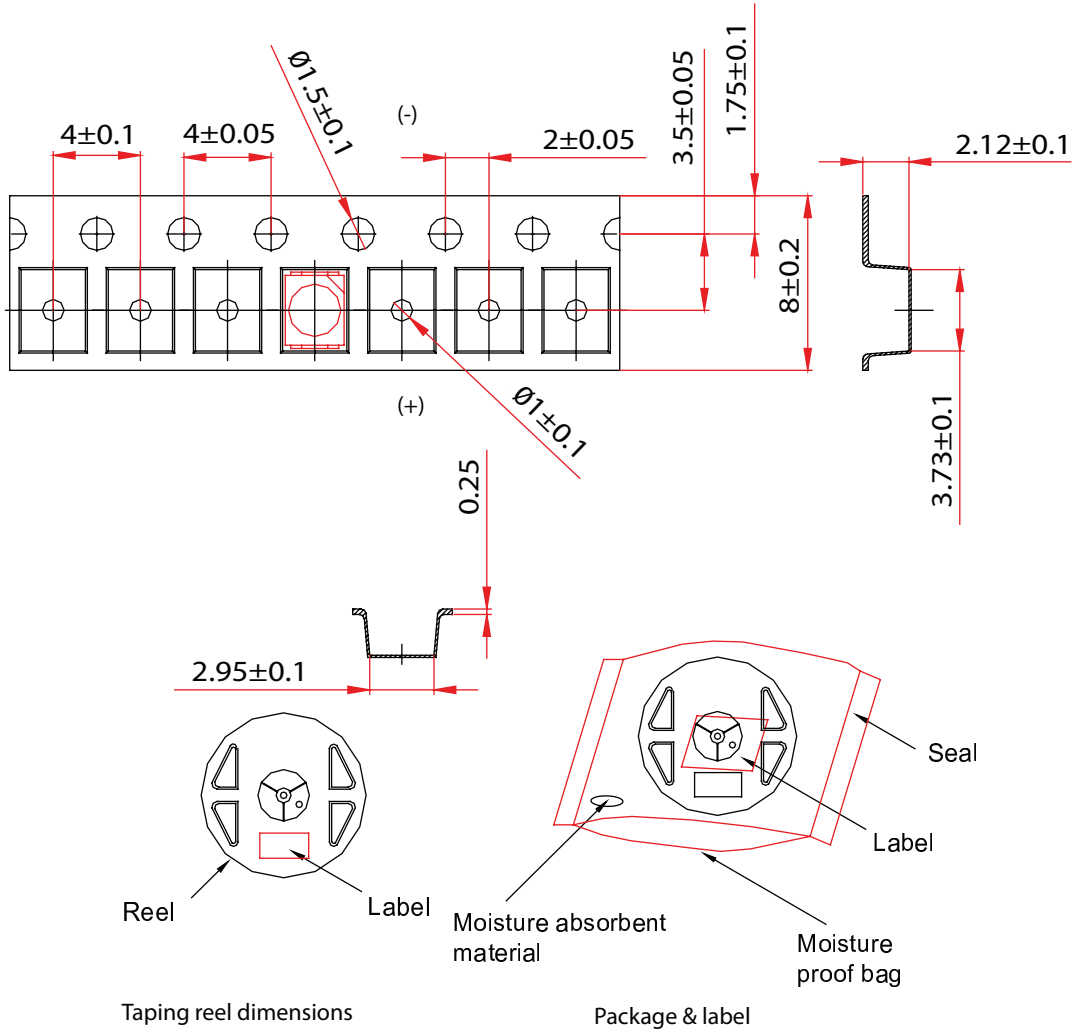

| Item   | Quantity | Total    | Dimensions(mm) |
|--|----------|----------|----------------|
| Reel   | 4,000pcs | 4,000pcs | R=178          |
| Starting with 150pcs empty, and 150pcs empty at the last |          |          |                |

## Revision History

---

| Versions | Description                  | Release Date |
|----------|------------------------------|--------------|
| 1        | Establish a Datasheet        | 2016/07/25   |
| 2        | Revise Voltage BIN Structure | 2016/08/10   |