

## PLCC Series

# 2835 0.5W II

## Horticulture Series Datasheet

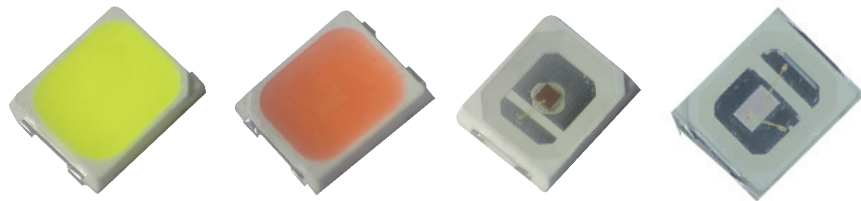

### Typical Applications :

- Indoor Cultivation
- Vertical Farm/ Green Wall
- Replacement HPS in Greenhouse
- Home Farming/ Hydroponic Pot

### Features :

- High Intensity and the color uniformity
- Beneficial for plant growth
- Reduce the cost of cultivation
- Superior ESD protection
- Level 3 on JEDEC moisture sensitivity analysis
- Easy to collocate the color spectrum
- RoHS compliant

## Table of Contents

---

General Information .....	3
Absolute Maximum Ratings .....	4
Characteristics .....	5
PPF Characteristic.....	6
PPF Characteristic.....	6
Radiometric Power Characteristic .....	7
Wavelength Bin Structure .....	8
Voltage Bin Structure .....	8
Mechanical Dimensions.....	9
Color BIN code.....	11
Characteristic curve.....	13
Reflow Profile .....	26
Reliability.....	27
Product Packaging Information.....	28
Revision History .....	29
About Edison Opto .....	29

## General Information

### Ordering Code Format

2      T      03      X5      FX      H      00      03      XXX  
 X1      X2      X3-X4      X5-X6      X7-X8      X9      X10-X11      X12-X13      X14-X16

X1		X2		X3-X4		X5-X6		X7-X8	
Type	Component	Series		Wattage		Color/CCT			
2	Emitter	T	PLCC	03	2835	X5	0.5W	FX	Cherry Red
								EX	Deep Red
								BX	Blue
								LX	Lime
								A0	Blue 5%
								A1	Blue 10%
								A2	Blue 15%
								A3	Blue 20%
								A4	Blue 30%

X9		X10-X11		X12-X13		X14-X16	
BIN				Voltage		Serial Number	
H	Horticulture	00	-	03	3V	-	-

## Absolute Maximum Ratings

Absolute maximum ratings ( $T_a=25^{\circ}\text{C}$ )

Parameter	Symbol	Value	Units
DC Forward Current	$I_F$	200	mA
Pulse Forward Current ( $t_p \leq 100\mu\text{s}$ , Duty cycle=0.25)	$I_{\text{pulse}}$	400	mA
Reverse Current	$I_R$	10	$\mu\text{A}$
Reverse Voltage	$V_R$	-	V
LED Junction Temperature	$T_J$	125	$^{\circ}\text{C}$
Operating Temperature	-	-40 ~ +85	$^{\circ}\text{C}$
Storage Temperature	-	-40 ~ +125	$^{\circ}\text{C}$
Soldering Temperature	$T_s$	Reflow Soldering : 255~260 $^{\circ}\text{C}$ /10~30sec Manual Soldering : 350 $^{\circ}\text{C}$ /3sec	

Notes:

1. Proper current derating must be observed to maintain junction temperature below the maximum at all time.
2. LEDs are not designed to be driven in reverse bias.
3.  $t_p$ : Pulse width time

## Characteristics

Parameter	Symbol	Value	Units
Viewing Angle	(Typ.) $2\theta_{1/2}$	120	Degree
Thermal resistance	-	20	°C/W
Wavelength	-	450-460(BX)(WP)	nm
		650-670(EX)(WP)	
		730-750(FX)(WP)	
x, y	center	LX: x=0.4077 y=0.5372	
		A0: x=0.5627 y=0.2471	
		A1: x=0.4820 y=0.2105	
		A2: x=0.4115 y=0.1700	
		A3: x=0.3705 y=0.1480	
		A4: x=0.3295 y=0.1260	
JEDEC Moisture Sensitivity	-	Level 3	-

Note:

1.  $2\theta_{1/2}$  is the off-axis angle where the Radiometric Power intensity is half of the axial Radiometric Power intensity.
2. CIE\_x/y tolerance:  $\pm 0.005$

## PPF Characteristic

Characteristics,  $I_f=150\text{mA}$ ,  $V_f = 5\text{V}$  and  $T_j=25^\circ\text{C}$

Color	Group	Min. PPF (umol/s)	Max. PPF (umol/s)	Order Code
BX	B2	0.7	0.8	2T03X5BXH0003002
	B3	0.8	0.9	
	B4	0.9	1.0	
EX	A4	0.5	0.6	2T03X5EXH0003002
	B1	0.6	0.7	
	B2	0.7	0.8	
	B3	0.8	0.9	
A0	B1	0.6	0.7	2T03X5A0H0003002
	B2	0.7	0.8	
	B3	0.8	0.9	
A1	B1	0.6	0.7	2T03X5A1H0003002
	B2	0.7	0.8	
	B3	0.8	0.9	
A2	B1	0.6	0.7	2T03X5A2H0003002
	B2	0.7	0.8	
	B3	0.8	0.9	
A3	B1	0.6	0.7	2T03X5A3H0003002
	B2	0.7	0.8	
	B3	0.8	0.9	
A4	B2	0.7	0.8	2T03X5A4H0003002
	B3	0.8	0.9	
	B4	0.9	1.0	

## Radiometric Power Characteristic

Characteristics,  $I_f=150\text{mA}$ ,  $V_f = 5\text{V}$  and  $T_j=25^\circ\text{C}$

Color	Group	Min. Radiometric Power(mW)@150mA	Max. Radiometric Power(mW)@150mA	Order Code
FX	W02	50	100	2T03X5FXH0003002
	W03	100	150	
	W04	150	200	

Note:

1. The Radiometric Power/ PPF performance is guaranteed within published operating conditions. Edison Opto maintains a tolerance of  $\pm 10\%$  on Radiometric Power measurements.

## Wavelength Bin Structure

Color	Group	Min. WP (nm)	Max. WP (nm)
BX	CW0	445	450
	CX0	450	455
	CY0	455	460
EX	EX0	650	670
FX	FX0	730	750

Note:  
Peak wavelength Measurement Allowance is  $\pm 2\text{nm}$ .

## Voltage Bin Structure

Color	Group	Min. Voltage (V)	Max. Voltage (V)
A0/A1/A2/A3/A4/LX	V01	2.8	3.1
	V02	3.1	3.4
BX	V01	2.8	3.1
	V02	3.1	3.4
EX	U04	1.9	2.2
	U05	2.2	2.5
FX	U03	1.6	1.9
	U04	1.9	2.2

Note:  
Forward voltage measurement allowance is  $\pm 0.06\text{V}$ .

## Mechanical Dimensions

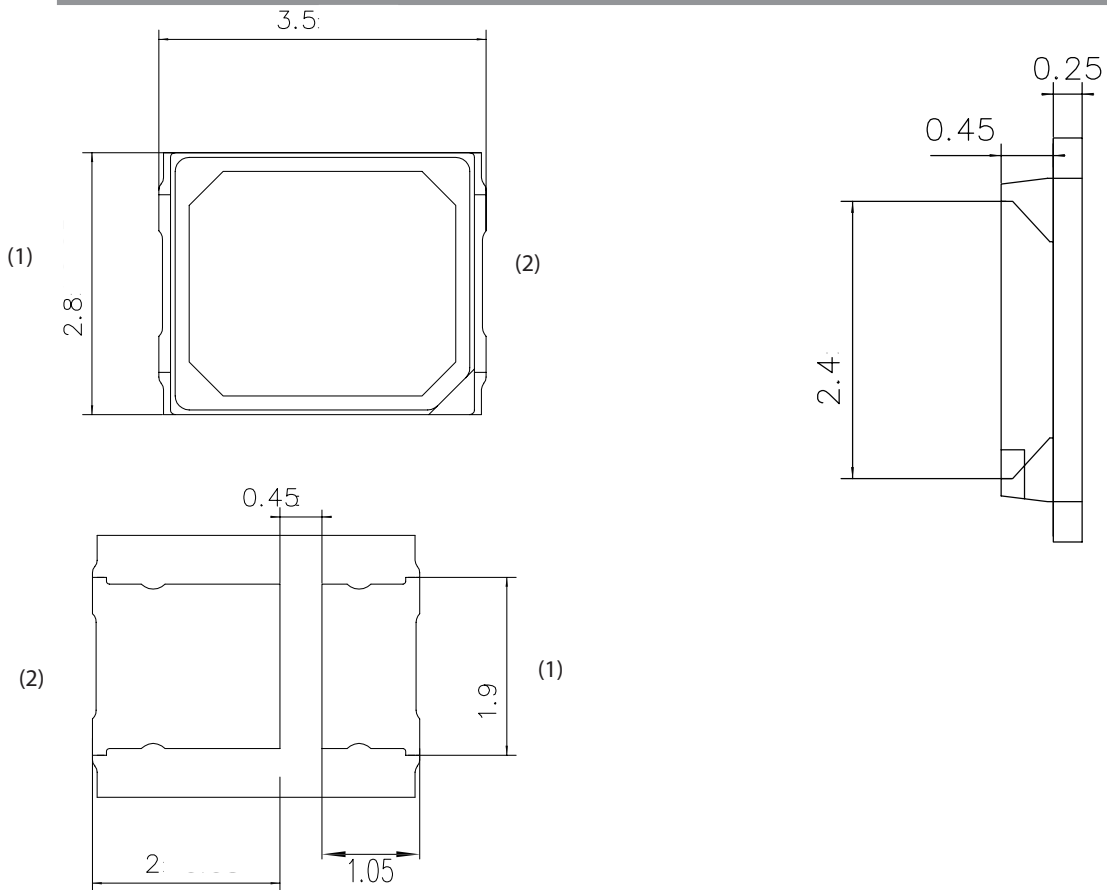

**Notes:**

1. All dimensions are measured in mm.
2. Tolerance :  $\pm 0.1$  mm
3. Ts = Soldering temperature (cathode side)

**Circuit**



2T03X5EXH0003002  
2T03X5FXH0003002

**Notes:**

1. All dimensions are measured in mm.
2. Tolerance :  $\pm 0.20$  mm

**Solder Pad**

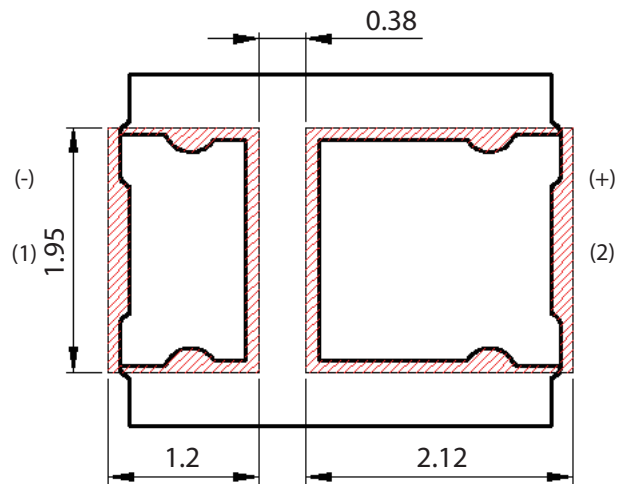

**Circuit**

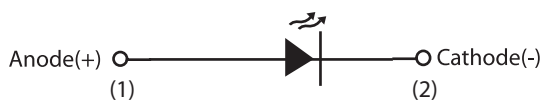

2T03X5A0H0003002  
2T03X5A1H0003002  
2T03X5A2H0003002  
2T03X5A3H0003002  
2T03X5A4H0003002  
2T03X5LXH0003002  
2T03X5BXH0003002

**Notes:**

1. All dimensions are measured in mm.
2. Tolerance :  $\pm 0.20$  mm

**Solder Pad**

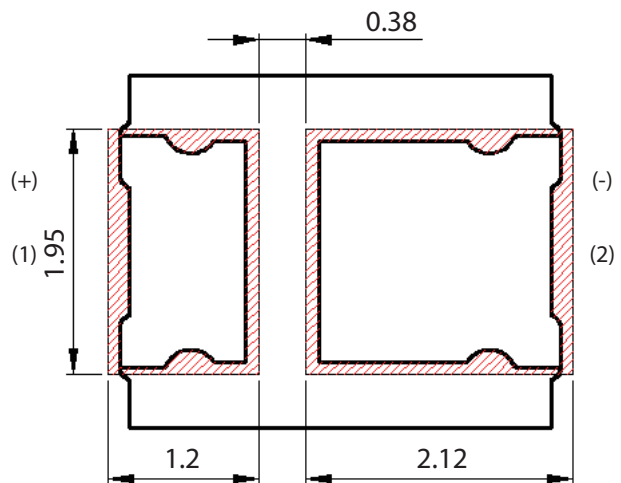

## Color BIN code

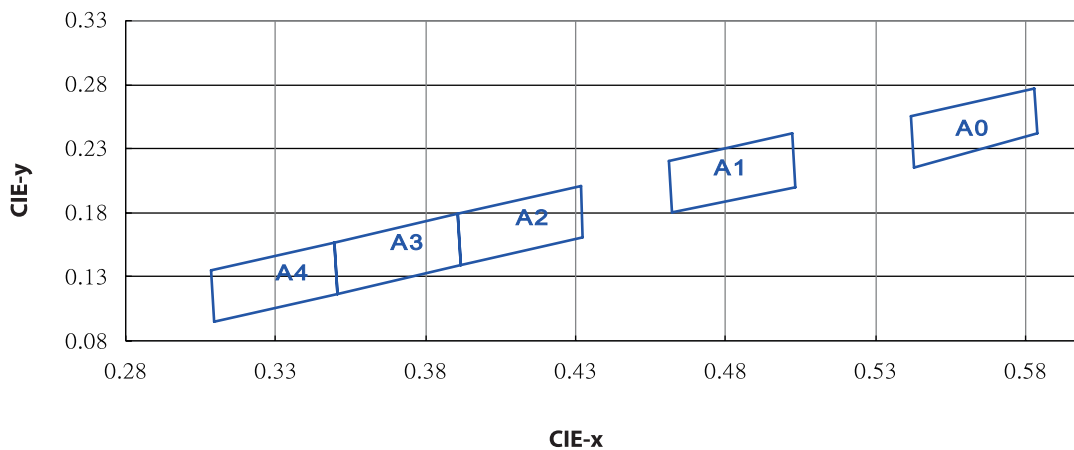

A0		A1	
X	Y	X	Y
0.5418	0.2550	0.4610	0.2200
0.5825	0.2770	0.5020	0.2420
0.5838	0.2415	0.5030	0.2000
0.5428	0.2150	0.4620	0.1800

A2		A3		A4	
X	Y	X	Y	X	Y
0.3905	0.1790	0.3905	0.1790	0.3495	0.1570
0.4315	0.2010	0.3915	0.1390	0.3505	0.1170
0.4325	0.1610	0.3505	0.1170	0.3095	0.0950
0.3915	0.1390	0.3495	0.1570	0.3085	0.1350

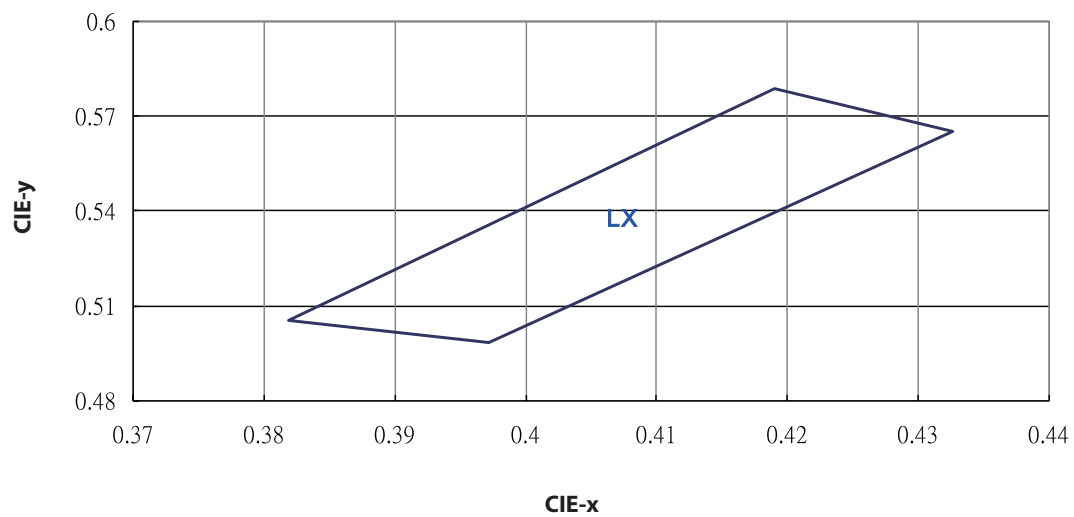

LX	
X	Y
0.4191	0.579
0.4327	0.5655
0.3972	0.4986
0.3819	0.5055

## Characteristic curve

### Color Spectrum

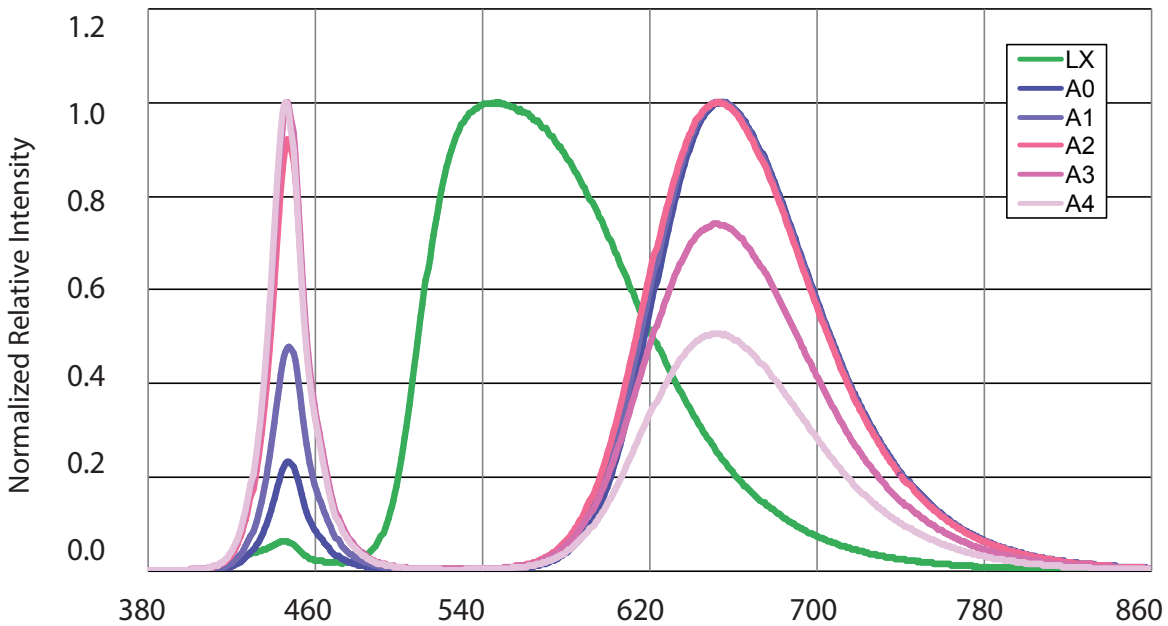
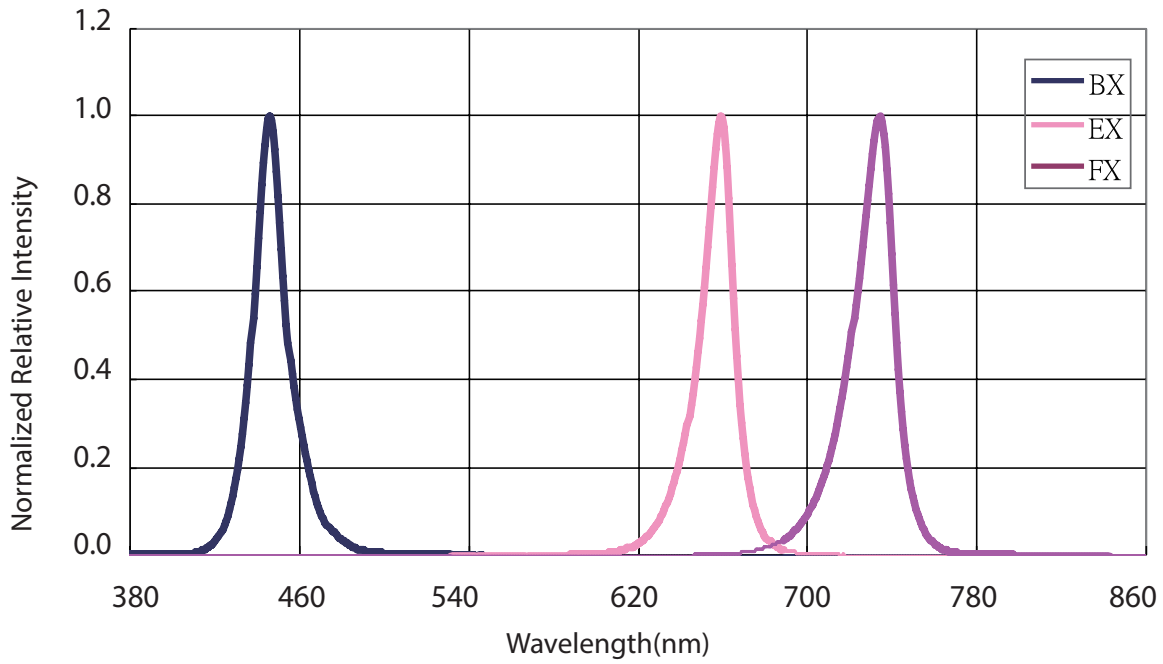

#### Notes:

Normalized Relative Intensity:  $\pm 0.15$

**Beam Pattern**

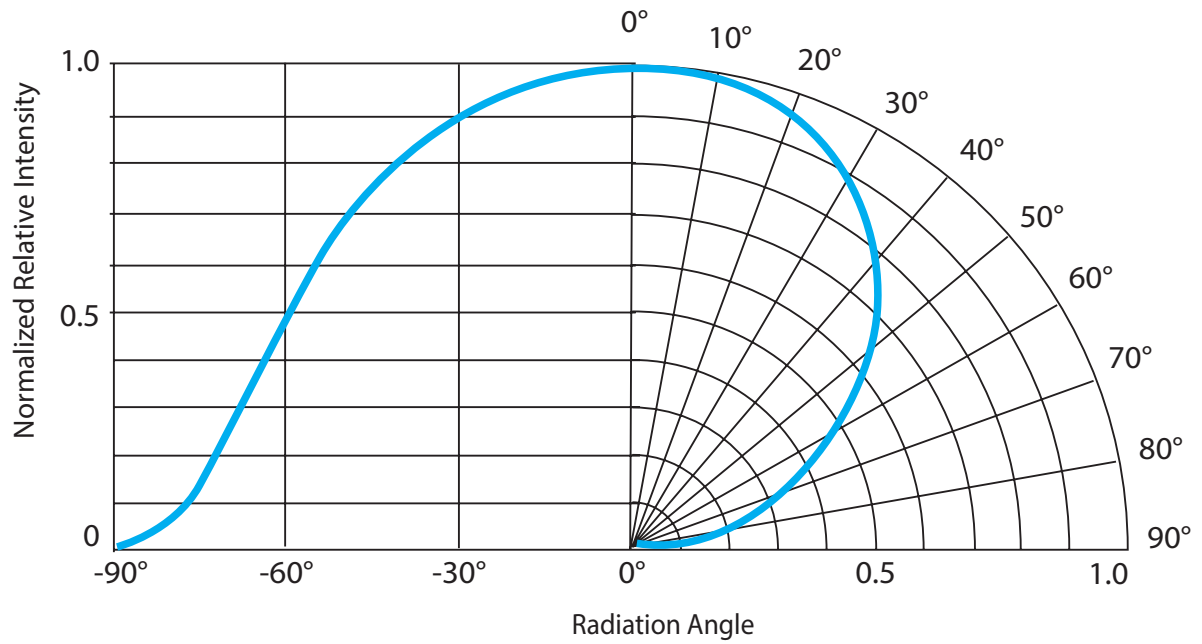

Beam pattern diagram for PLCC series

### Forward Current vs. Forward Voltage

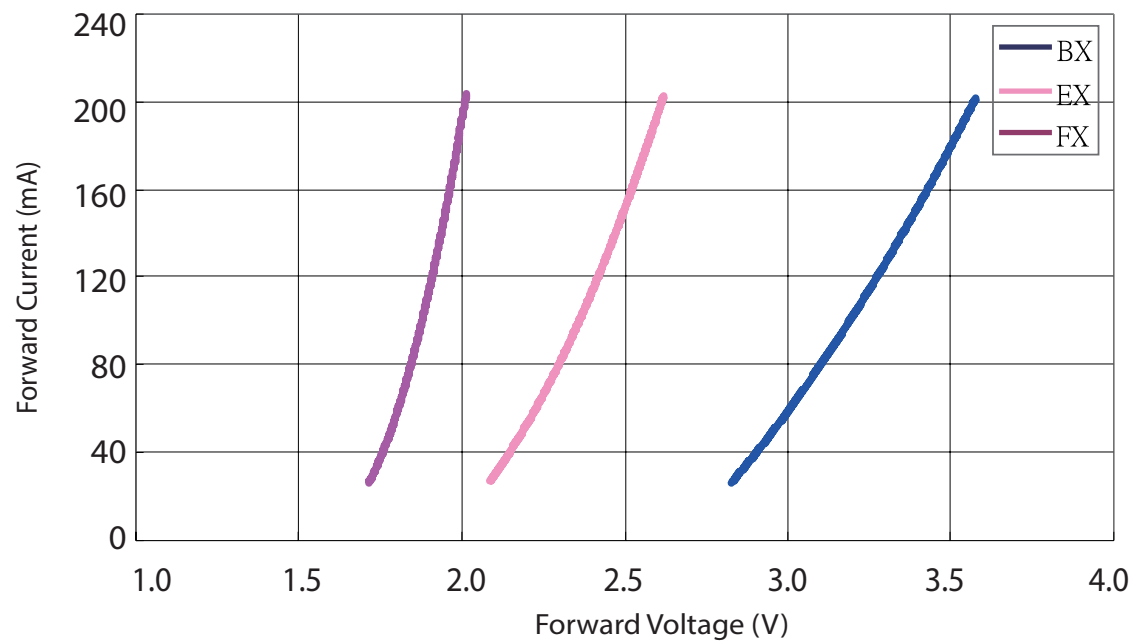
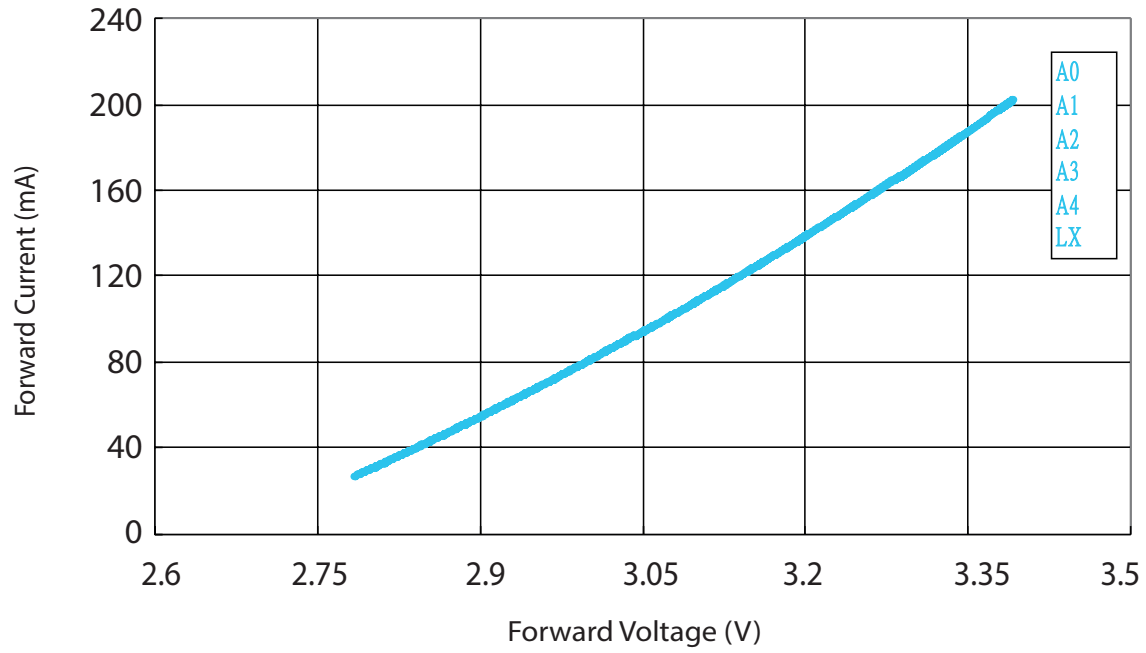

### Forward Voltage vs. Junction Temperature

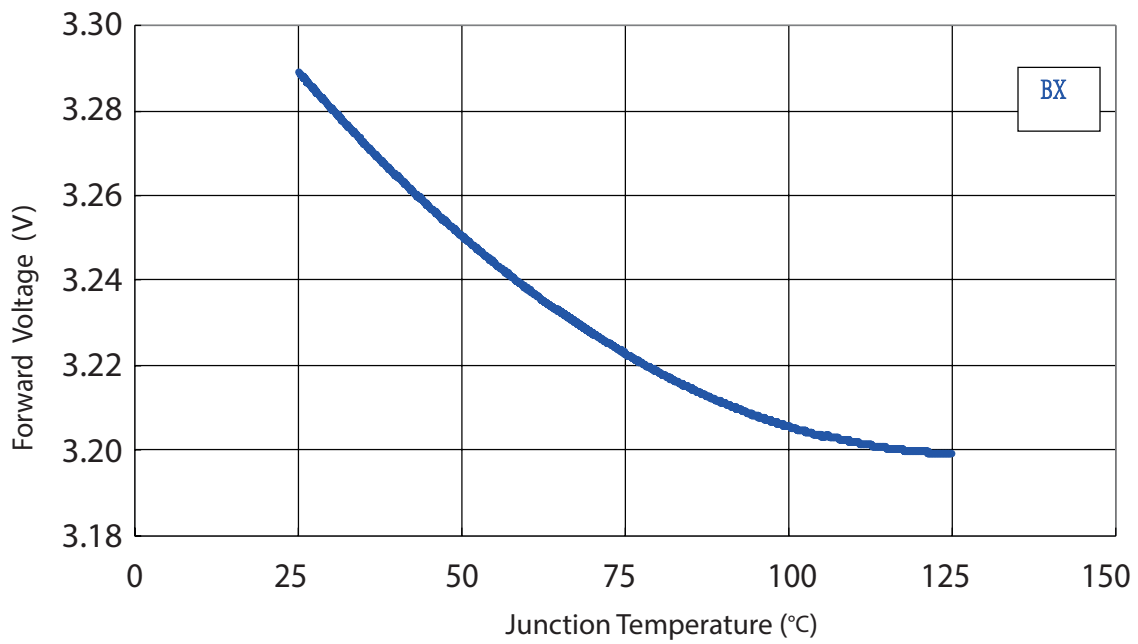
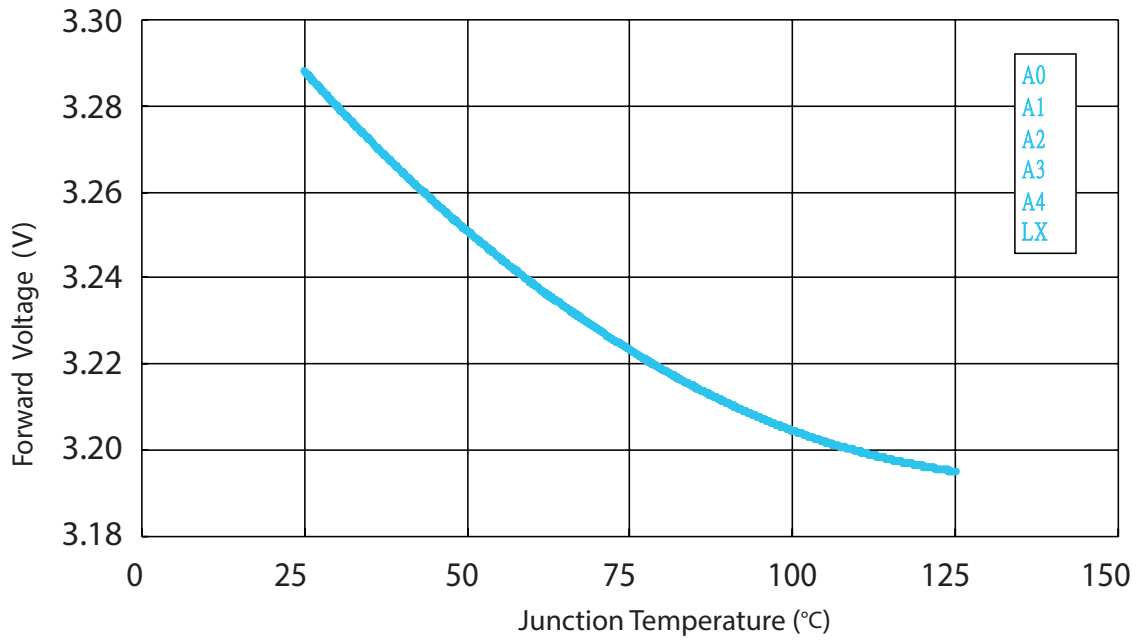

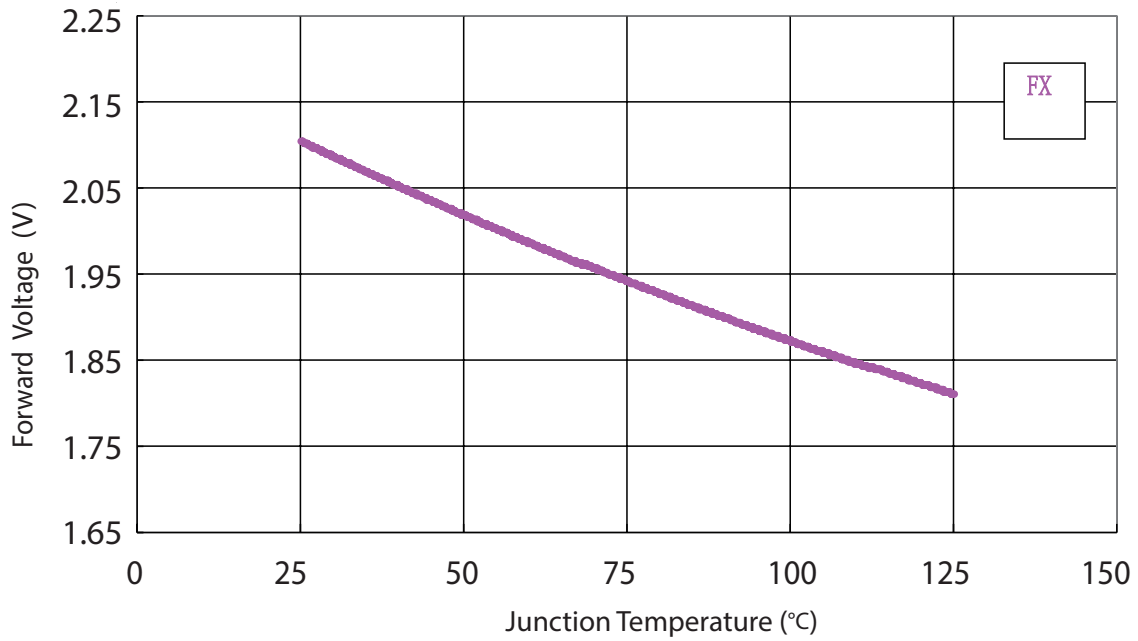
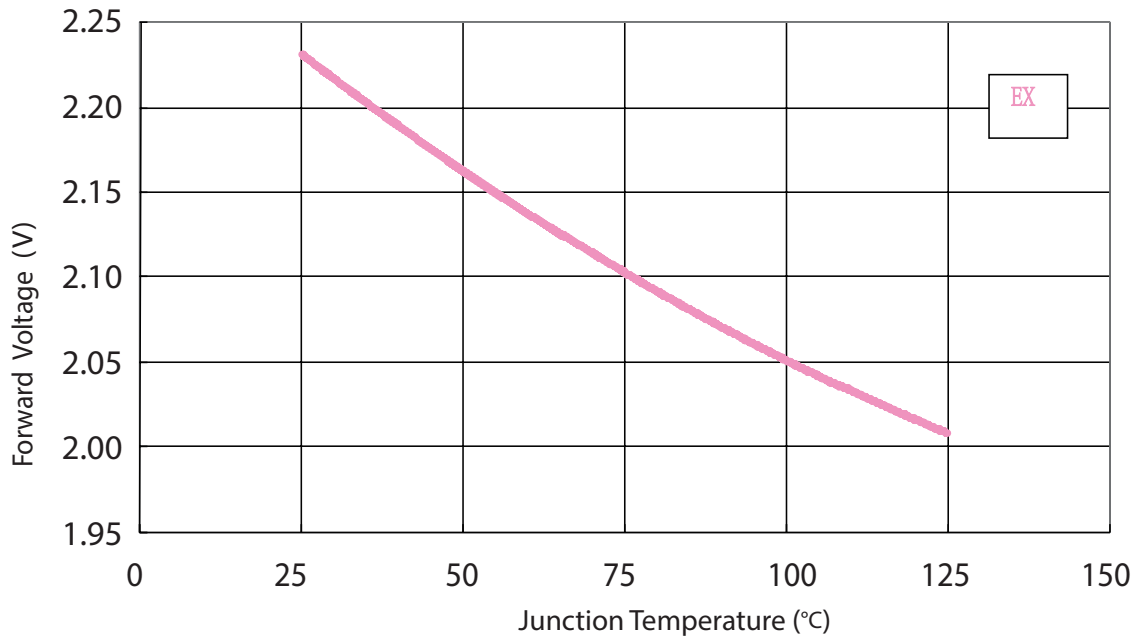

### Relative PPF Intensity vs. Forward Current

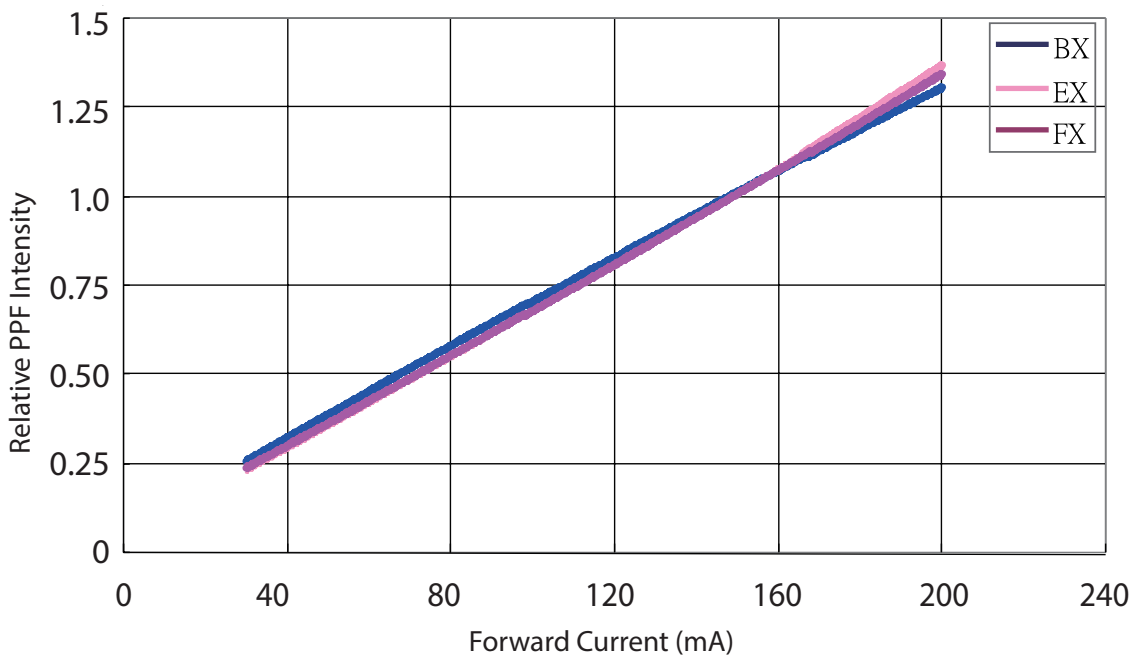
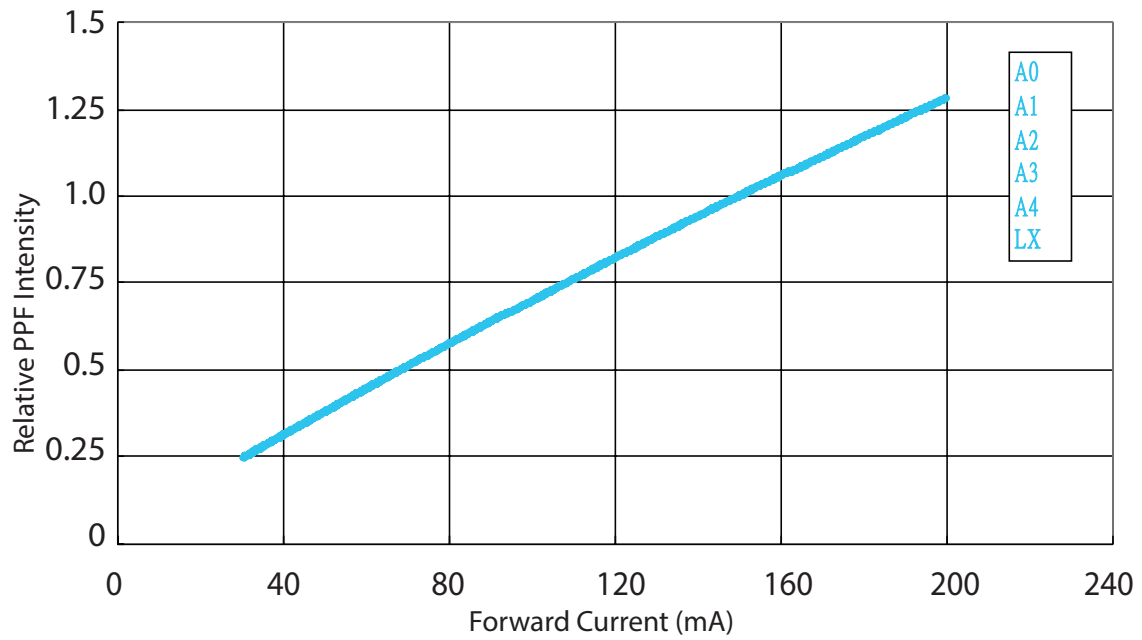

### Relative PPF Intensity vs. Junction Temperature

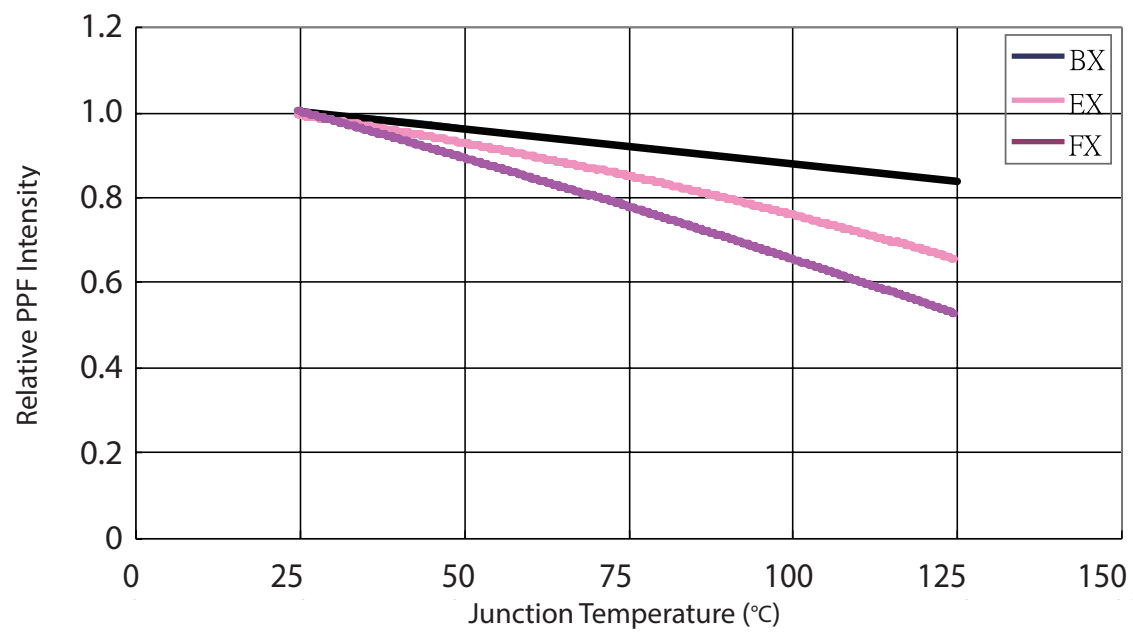
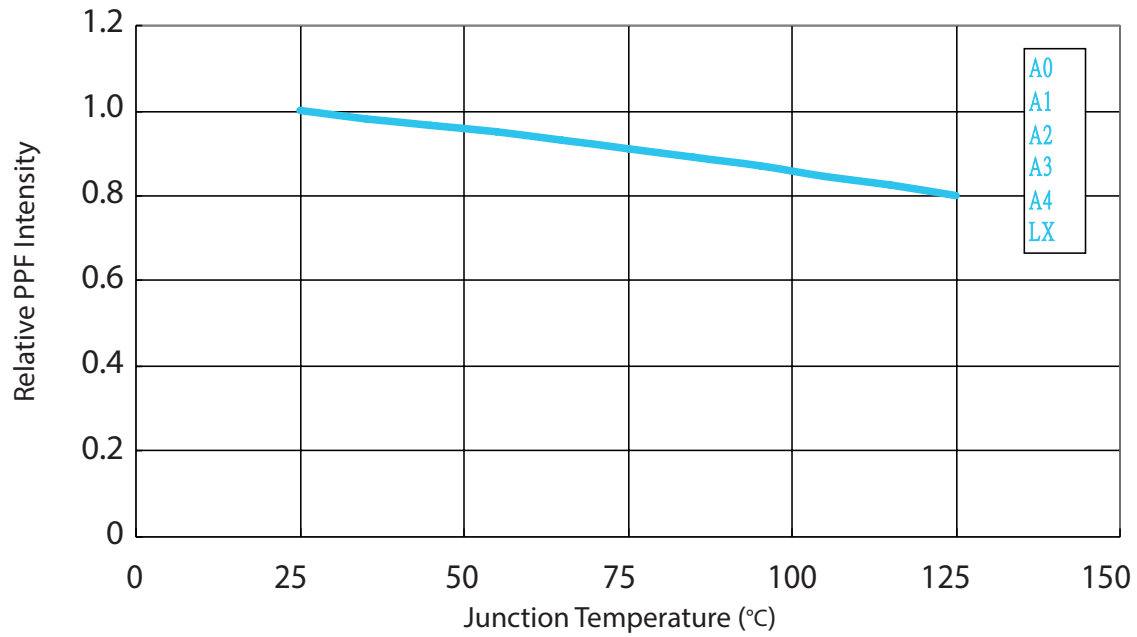

### $\Delta x, \Delta y$ vs. Forward Current

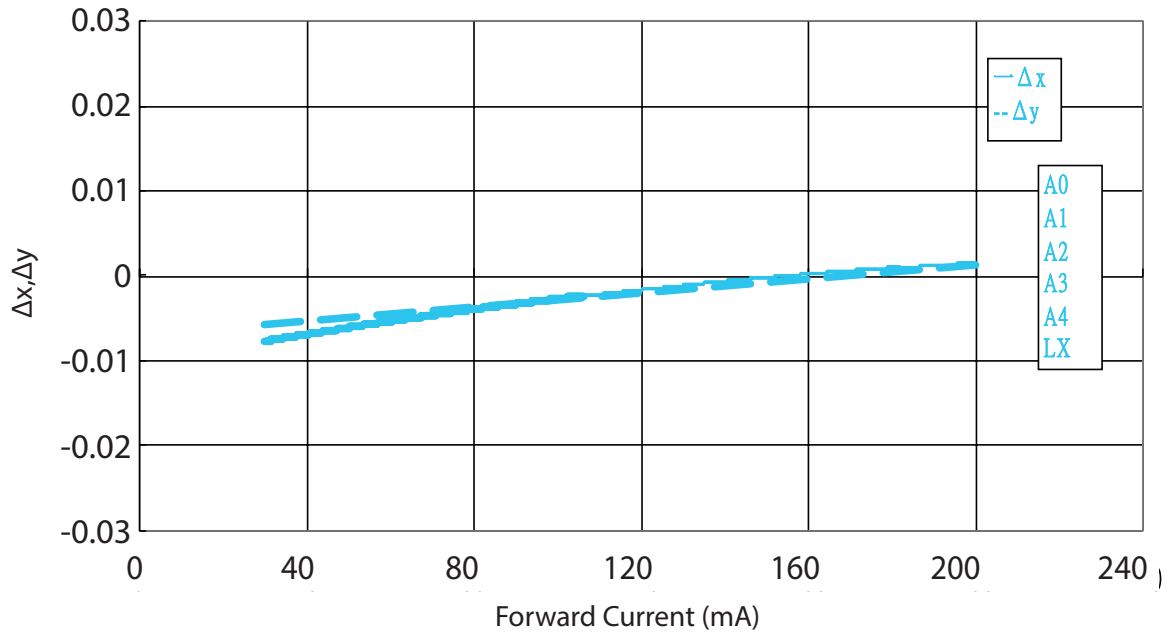

### $\Delta x, \Delta y$ vs. Junction Temperature

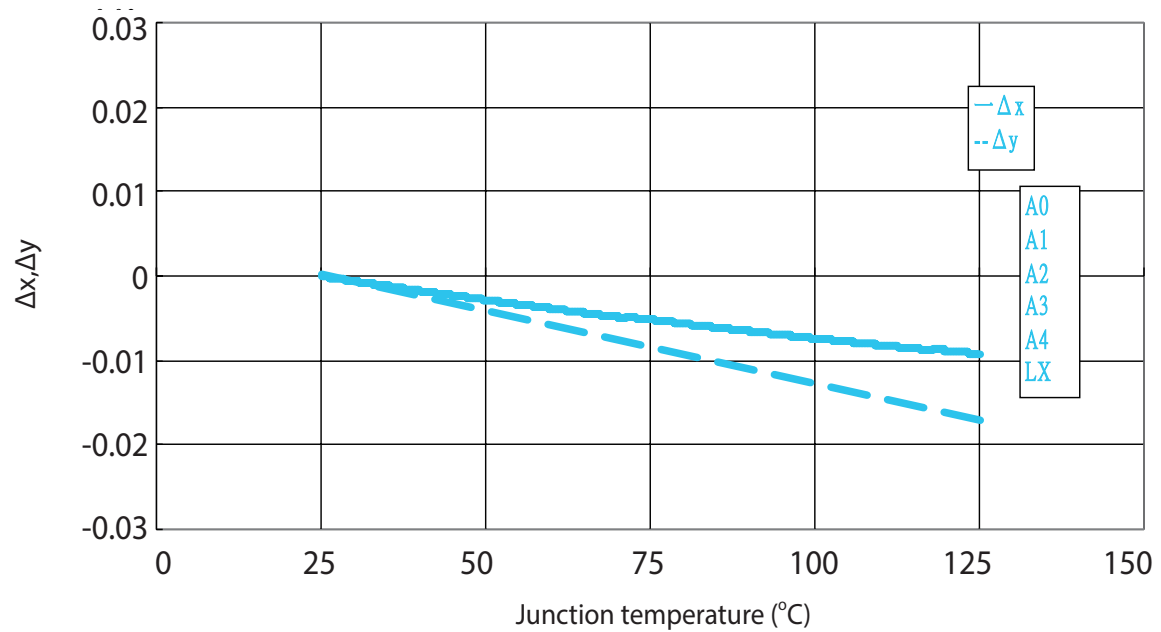

**Wavelength(Wp) vs. Forward Current**

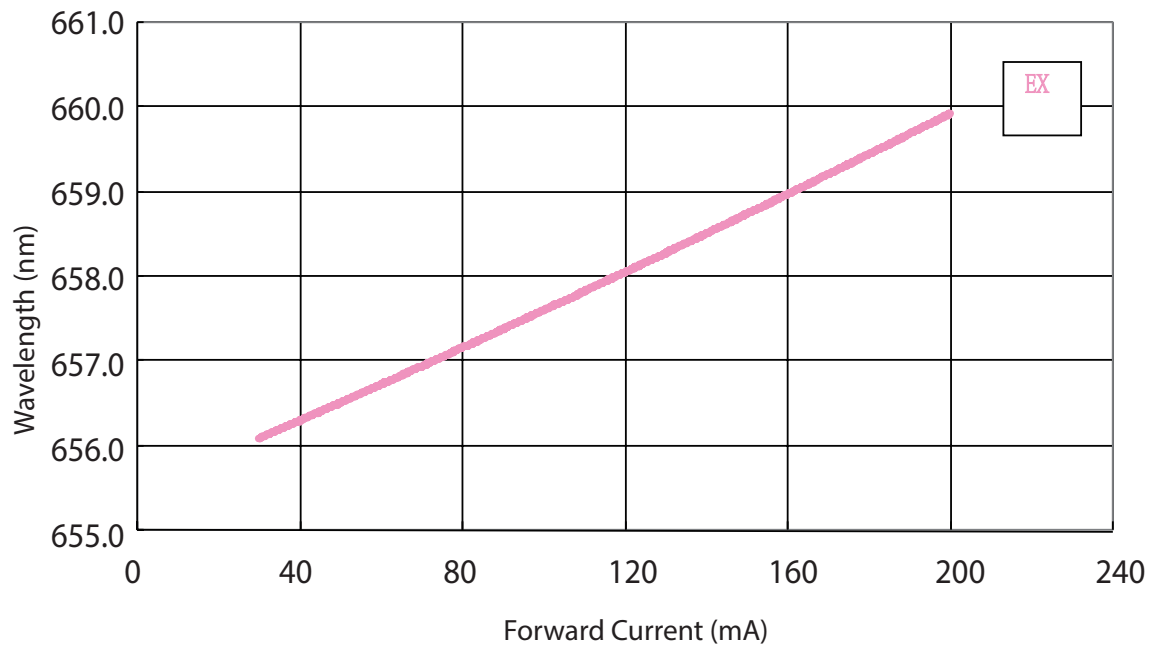
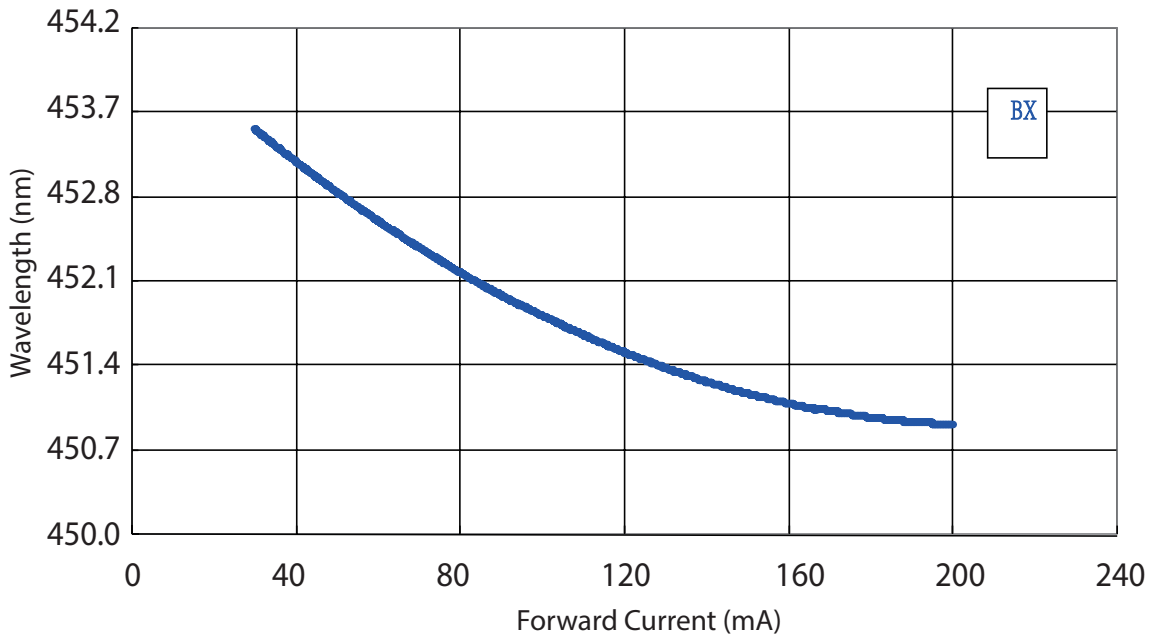

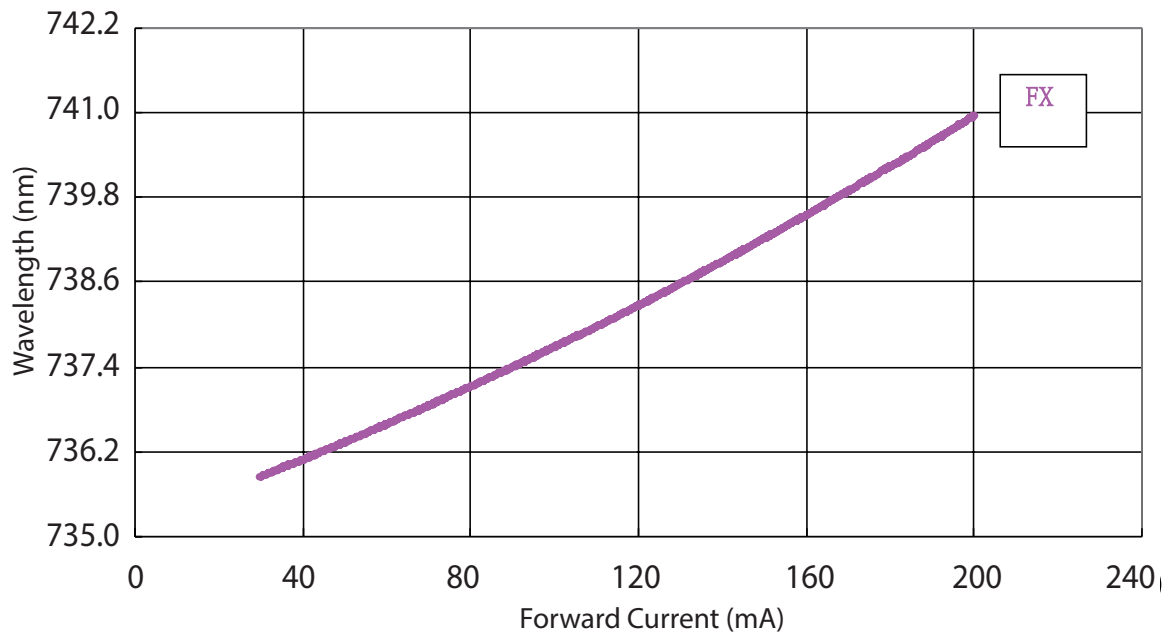

### Wavelength(Wp) vs. Junction Temperature

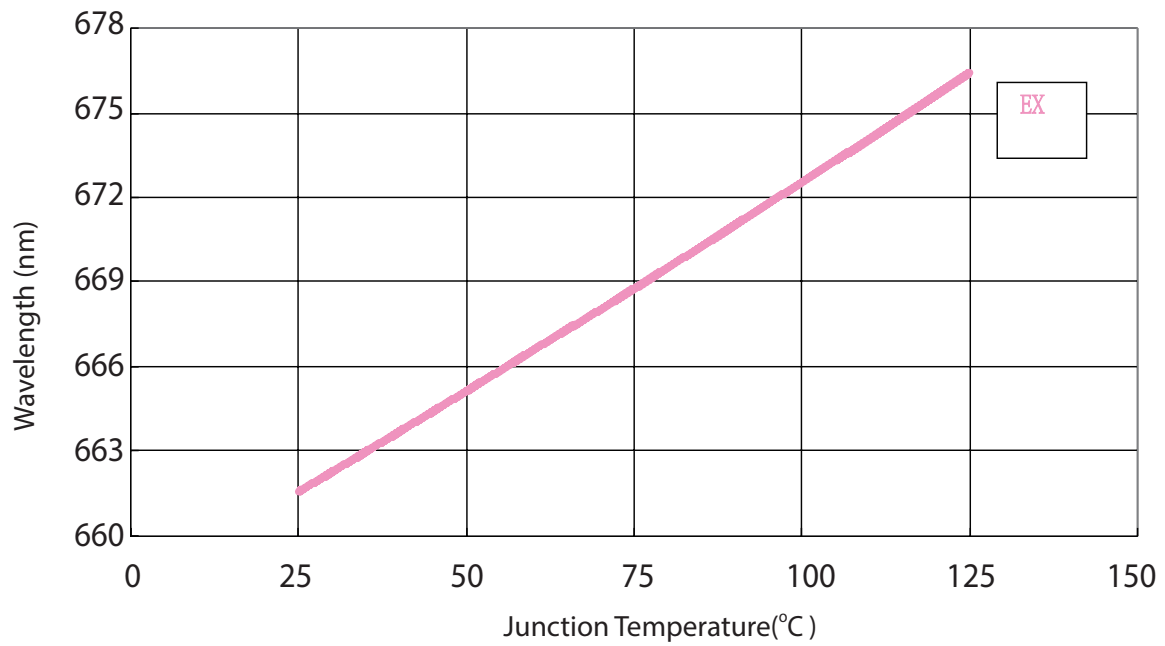
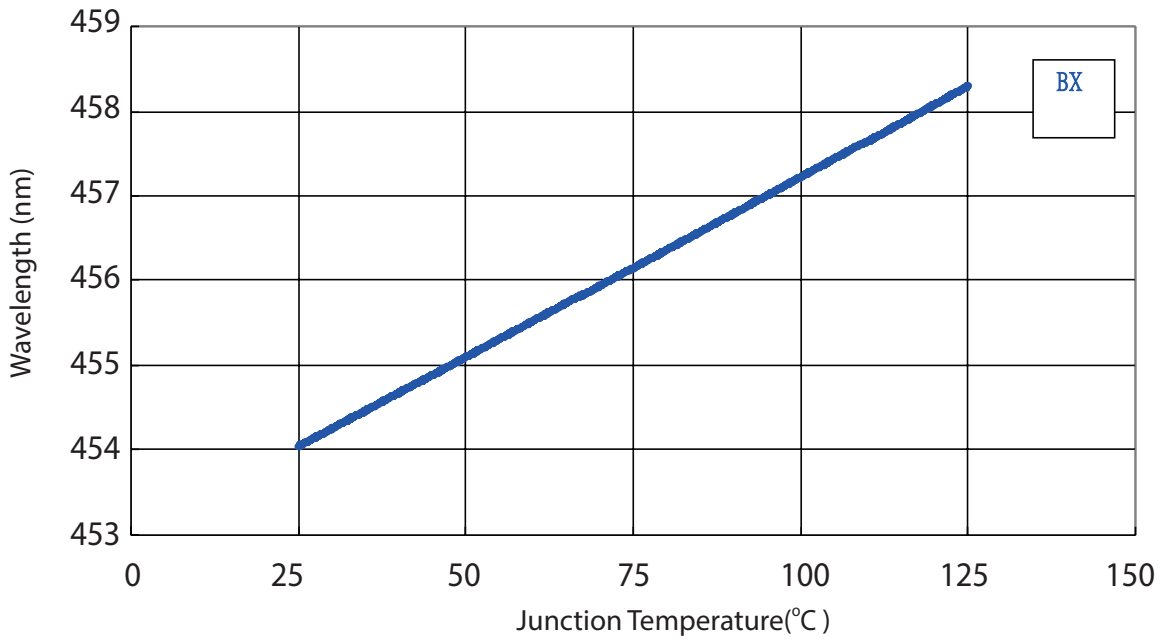

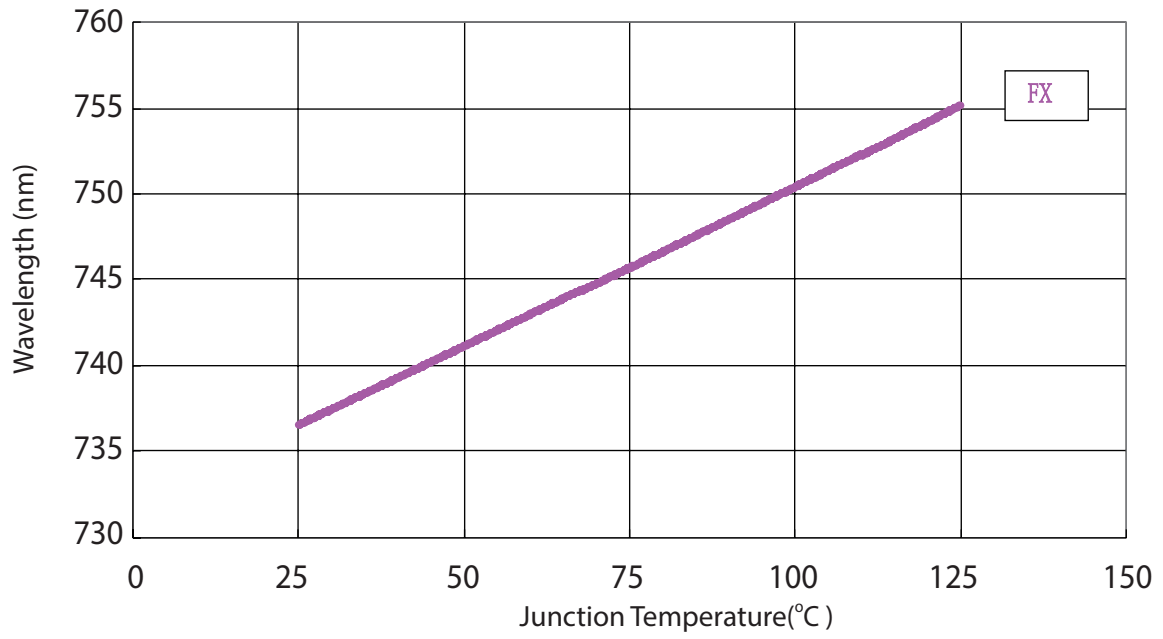

### Maximum Current vs. Ambient Temperature

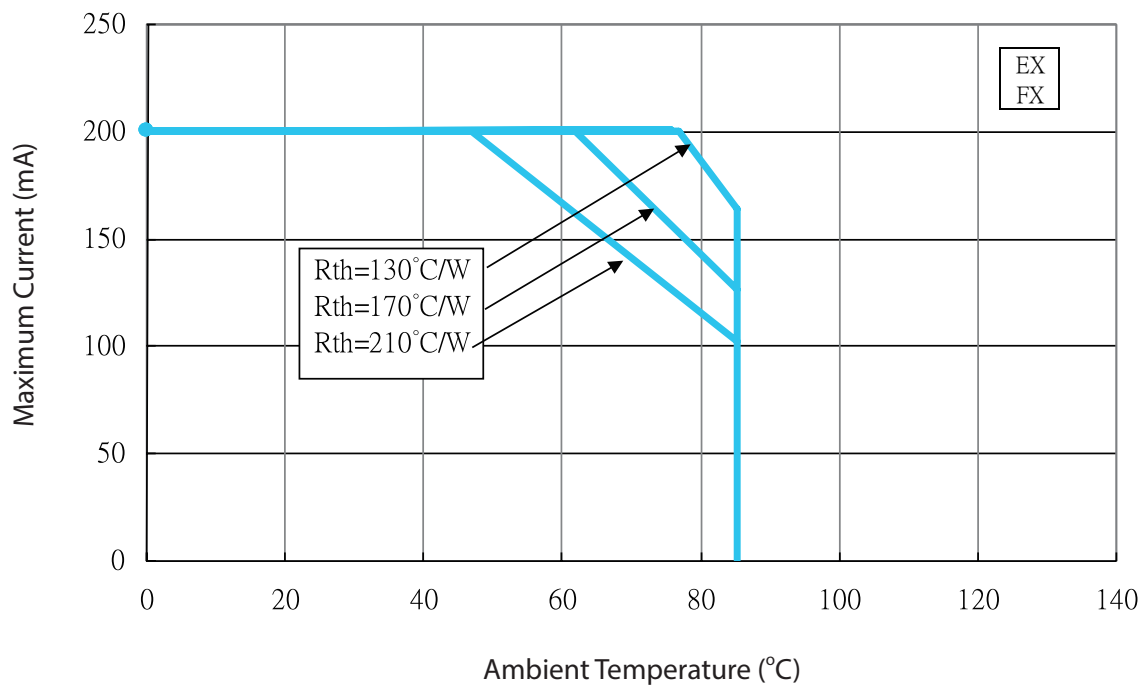
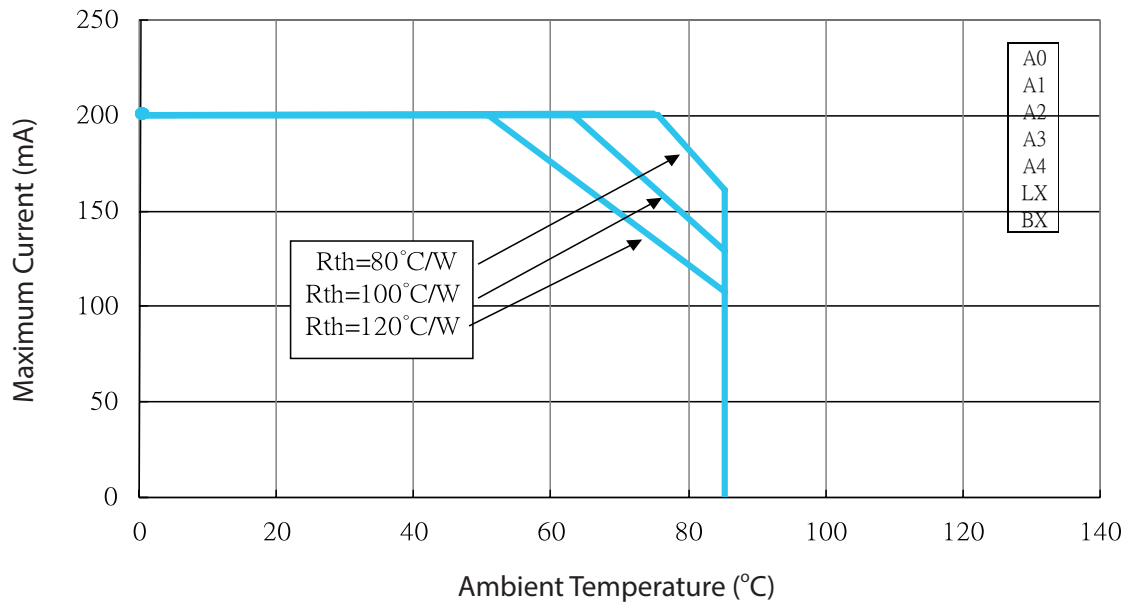

## Reflow Profile

The following reflow profile is from IPC/JEDEC J-STD-020D which provided here for reference.

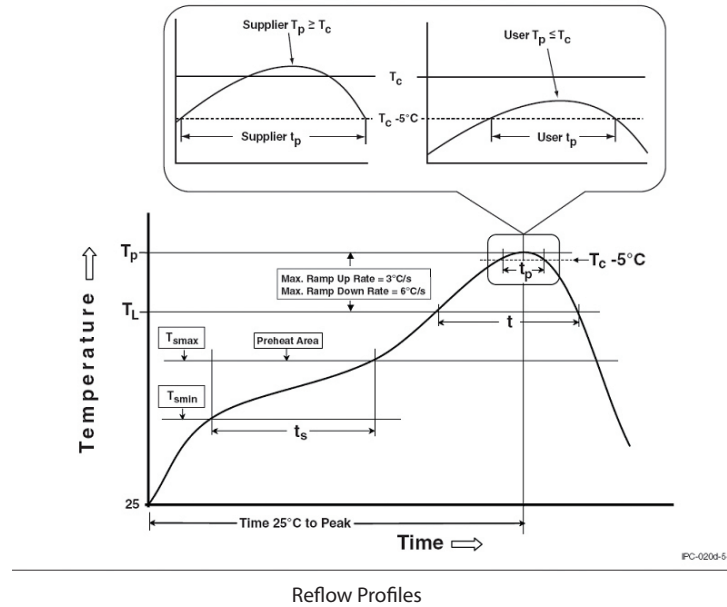

### Classification Reflow Profiles

Profile Feature	Pb-Free Assembly
Preheat & Soak	
Temperature min ( $T_{smin}$ )	$150^\circ\text{C}$
Temperature max ( $T_{smax}$ )	$200^\circ\text{C}$
Time ( $T_{smin}$ to $T_{smax}$ ) ( $t_s$ )	60-120 seconds
Average ramp-up rate ( $T_{smax}$ to $T_p$ )	$3^\circ\text{C/second max.}$
Liquidous temperature ( $T_L$ )	$217^\circ\text{C}$
Time at liquidous ( $t_L$ )	60-150 seconds
Peak package body temperature ( $T_p$ )*	$255^\circ\text{C} \sim 260^\circ\text{C}^*$
Classification temperature ( $T_c$ )	$260^\circ\text{C}$
Time ( $t_p$ )** within $5^\circ\text{C}$ of the specified classification temperature ( $T_c$ )	30** seconds
Average ramp-down rate ( $T_p$ to $T_{smax}$ )	$6^\circ\text{C/second max.}$
Time $25^\circ\text{C}$ to peak temperature	8 minutes max.

Notes:

- \* Tolerance for peak profile temperature ( $T_p$ ) is defined as a supplier minimum and a user maximum.
- \*\* Tolerance for time at peak profile temperature ( $t_p$ ) is defined as a supplier minimum and a user maximum.

## Reliability

NO .	Test Item	Test Condition	Remark
1	Temperature Cycle	-40°C~100°C 30, 30, mins	100 Cycle
2	Thermal Shock	-40°C~100°C 15, 15 mins ≤ 10 sec	100 Cycle
3	Resistance to Soldering Heat	T <sub>SOL</sub> =260°C, 30 sec	3 times
4	Moisture Resistance	25°C~65°C 90% RH 24 hrs / 1 cycle	10 Cycle
5	High-Temperature Storage	T <sub>A</sub> =100°C	1,000 hrs
6	Humidity Heat Storage	T <sub>A</sub> =85°C RH=85%	1,000 hrs
7	Low-Temperature Storage	T <sub>A</sub> =-40°C	1,000 hrs
8	Operation Life test	25°C	1,000 hrs
9	High Temperature Operation Life test	85°C	1,000 hrs
10	High Humidity Heat Life Test	85°C, 85%RH	1,000 hrs
11	ON/OFF Test	30 sec ON, 30 sec OFF	1.5W times

### Failure Criteria

Item	Criteria for Judgment	
	Min.	Max.
Lumen Maintenance	85%	-
Δu'v'	-	0.006
Forward Voltage	-	Initial Data x 1.1
Reverse Current	-	10 μA
Resistance to Soldering Heat	No dead lamps or visual damage	

### Cautions

LEDs should be stored or lighted in the environment of no sulfur.

Some materials, such as plastic seals, printing ink, enclosures and adhesives, may contain sulfur.

LEDs also should not be exposed in the acid or halogen environment.

## Product Packaging Information

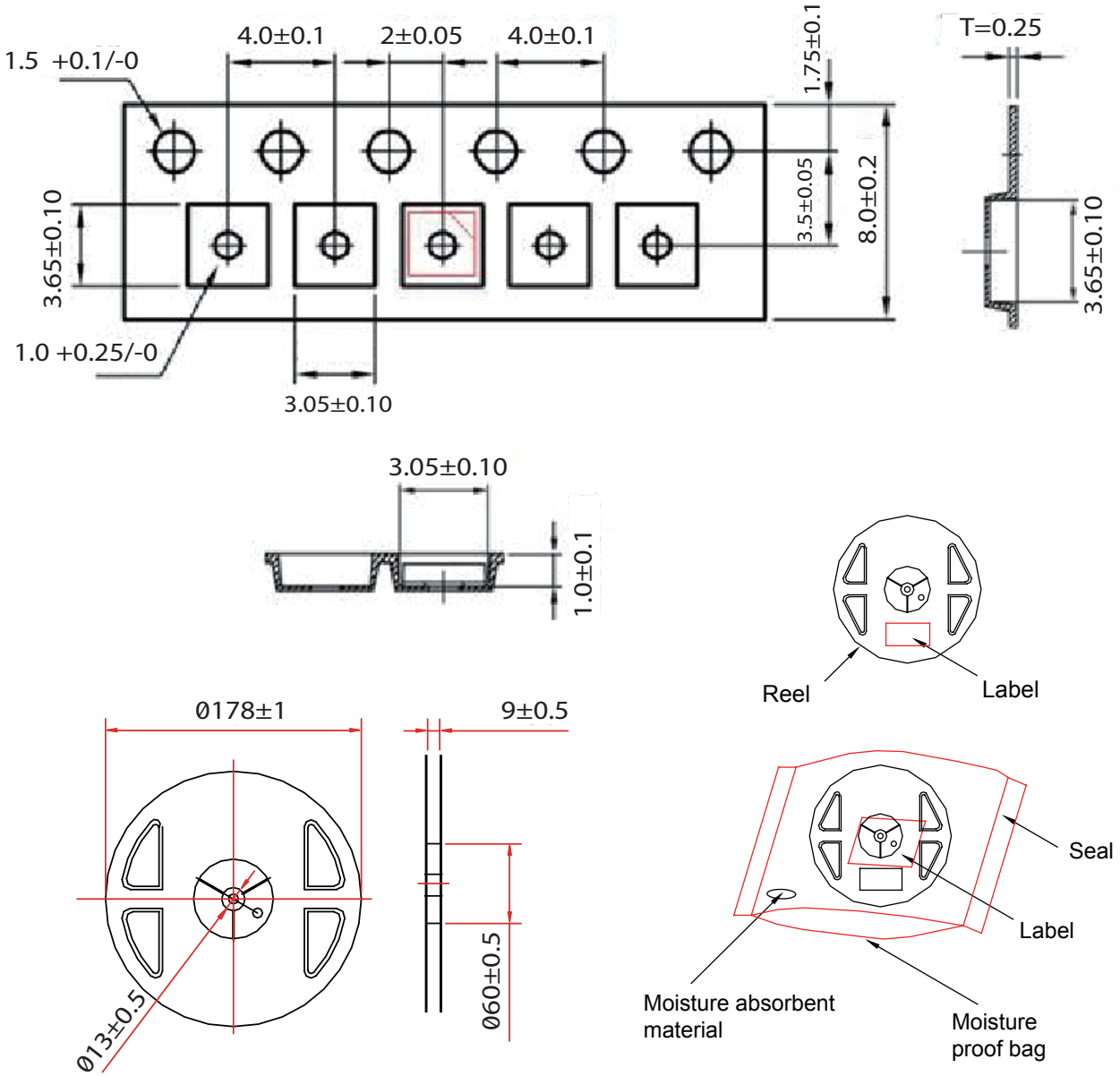

Item	Quantity	Total	Dimensions(mm)
Reel	4,000pcs	4,000pcs	R=178

## Revision History

Versions	Description	Release Date
1	Establish a datasheet	2020/12/25
2	Update the bin group	2021/04/08

## About Edison Opto

Edison Opto is a leading manufacturer of high power LED and a solution provider experienced in LDMS. LDMS is an integrated program derived from the four essential technologies in LED lighting applications- Thermal Management, Electrical Scheme, Mechanical Refinement, Optical Optimization, to provide customer with various LED components and modules. More Information about the company and our products can be found at [www.edison-opto.com](http://www.edison-opto.com)

Copyright©2021 Edison Opto. All rights reserved. No part of publication may be reproduced or transmitted in any form or by any means, electronic or mechanical, including photo copy, recording or any other information storage and retrieval system, without prior permission in writing from the publisher. The information in this publication are subject to change without notice.

[www.edison-opto.com](http://www.edison-opto.com)

For general assistance please contact:  
[service@edison-opto.com.tw](mailto:service@edison-opto.com.tw)

For technical assistance please contact:  
[LED.Detective@edison-opto.com.tw](mailto:LED.Detective@edison-opto.com.tw)