

2835R Series

Standard 2835 package to address retrofit applications

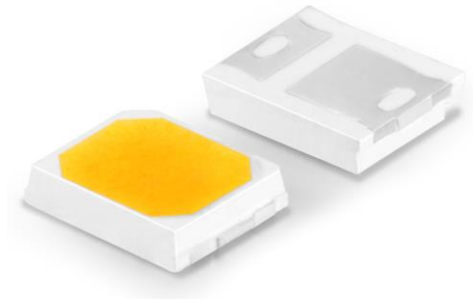

2835R Series is a complementary portfolio with optimized performance and bin construction for the retrofit space. With an industry standard footprint, it provides the perfect balance between performance and cost efficiency for a variety of applications.

FEATURES AND BENEFITS

Flexible voltage configurations to comply with various different system solutions

Industry standard footprint for drop-in replacement designs

High maximum drive current to allow for reduction of LED count

Part Number Nomenclature

Part numbers for the 2835R Series follow the convention below:

L 1 2 8 – A A B B R C 3 5 0 0 D D D

Where:

- A A - designates nominal CCT (27=2700K, 30=3000K, 35=3500K, 40=4000K, 50=5000K, 57=5700K, 65=6500K)
- B B - designates nominal CRI (70=70CRI, 75=75CRI, 80=80CRI and 90=90CRI)
- C - designates voltage (A=3V, B=6V, C=9V, D=18V, E=36V)
- D D D - designates Lumileds internal code (0A1, 0B1, 0C1, etc.=shares the same base part)

Therefore, the following part number is used for a 2835R 3000K, 80CRI, 36V LED:

L 1 2 8 – 3 0 8 0 R E 3 5 0 0 0 A 1

Lumen Maintenance

Please contact your local Sales Representative or Lumileds Technical Solutions Manager for more information about the long- term performance of this product.

Environmental Compliance

Lumileds LLC is committed to providing environmentally friendly products to the solid-state lighting market. The 2835R Series is compliant to the European Union directives on the restriction of hazardous substances in electronic equipment, namely the RoHS Directive 2011/65/EU and REACH Regulation (EC) 1907/2006. Lumileds LLC will not intentionally add the following restricted materials to its products: lead, mercury, cadmium, hexavalent chromium, polybrominated biphenyls (PBB) or polybrominated diphenyl ethers (PBDE).

Mass Production List of 2835R Series 批量生产目录

Product 产品	Product Number 产品型号	CCT	Ra Min	Φ(lm) Min	Φ(lm) Typ	Test conditions 测试条件
2835R 3V	L128-2780RA35002F1	2700	80	60	63	25°C, IF=150mA
	L128-3080RA35002F1	3000	80	62	65	
	L128-3580RA35002F1	3500	80	62	67	
	L128-4080RA35002F1	4000	80	65	69	
	L128-5080RA35002F1	5000	80	65	69	
	L128-5780RA35002F1	5700	80	65	69	
	L128-6580RA35002F1	6500	80	65	69	

Notes:备注

- 1.Tolerance of Color Rendering Index: ± 2 . 显色指数公差 ± 2
- 2.Tolerance of Luminous flux: $\pm 5\%$.光通量公差 $\pm 5\%$

Absolute maximum ratings 最大限定参数(Ta=25°C)

Parameter 项目名称	Symbol 符号	Value 规格	Unit 单位
Power dissipation 消耗功率	Pd	480	mW
Forward current 正向电流	IF	300	mA
Reverse voltage 反向电压	VR	5	V
Operating temperature range 工作温度范围	Top	-35~+100	°C
Storage temperature range 储存温度范围	Tstg	-35~+85	°C
Heatresistance 热阻	Rth	35	°C
Junction temperature 结温	Tj	125	°C
Electrostatic Discharge 抗静电能力	ESD	2000	V

Electro-optical characteristics 主要光电参数(Ta=25°C)

Parameter 项目名称	Symbol 符号	Min	Typ	Max	Unit	Test Condition 测试条件
Forward voltage 正向电压	Vf	2.8		3.1	V	IF=150mA
Luminous flux 光通量	Φ	60			lm	IF=150mA
Viewing Angle 角度	2 θ 1/2		120		Deg	IF=150mA
Reverse current 反向电流	IR			10	μA	Vr=5V
Color Index 显色指数	Ra	80				IF=150mA

NOTES 注释:

- * The measurement of forward voltage maintains a tolerance of $\pm 0.05V$, flux maintains a tolerance of $\pm 5\%$.
- * 正向电压测量误差 $\pm 0.05V$ ，光通量 $\pm 5\%$ 。
- * Ra measurement tolerance is ± 2 .
- * Ra 测量误差为 ± 2 。
- * Rth j-sp is the thermal resistance from LED junction to solder point on MCPCB with electrical power.
- * Rth j-sp 是通电时从 PN 结到铝基板焊点的热阻。

Reliability Test Items And Conditions 信赖性测试项目及条件

Test Items 测试项目	Test condition 测试条件	Time 时间	Quantity 数量	Ac/Re 接受、拒收
Reflow Soldering 回流焊	Temp. :260°C/10sec.	6Min.	22pcs	0/22
Thermal Shock 冷热冲击	-40~125C, 15min dwell, 10sec transfer	100Cycles	22pcs	0/22
High Temperature High Humidity life Test 高温高湿通电	85°C,85%RH, IF=150mA	1000Hrs.	10pcs	0/10
Low Temperature Storage 低温保存	Ta=-40°C	1000Hrs.	10pcs	0/10
High Temperature Storage 高温保存	Ta=100°C	1000Hrs.	10pcs	0/10
High Temperature Operation Life Test 高温通电	Ta=85°C, IF =150mA.	1000Hrs.	10pcs	0/10

Failure Criteria 失效判断标准

Item 项目	Symbol 符号	Failure Criteria 判断标准
Luminous Flux 光通量	Lm	$\cong 70\%$
Forward voltage 正向电压	VF	$\pm 10\%$
Colour 坐标点	CIE_X CIE_y	± 0.01

Typical optical characteristics curves 光电特性曲线

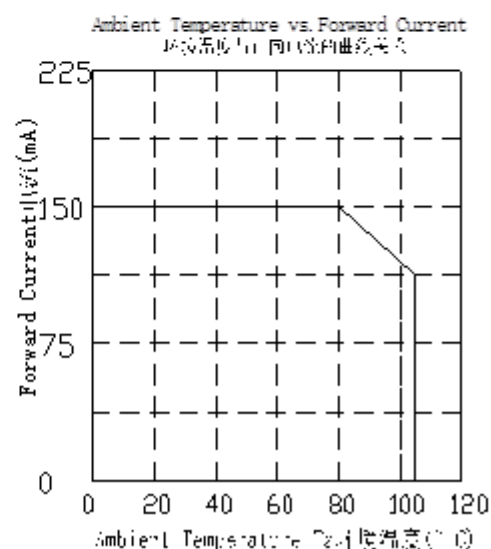
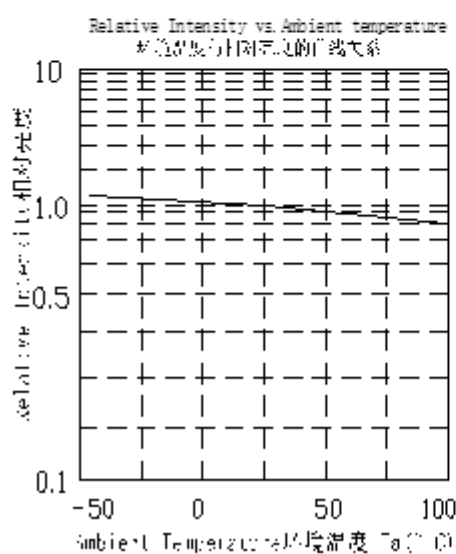
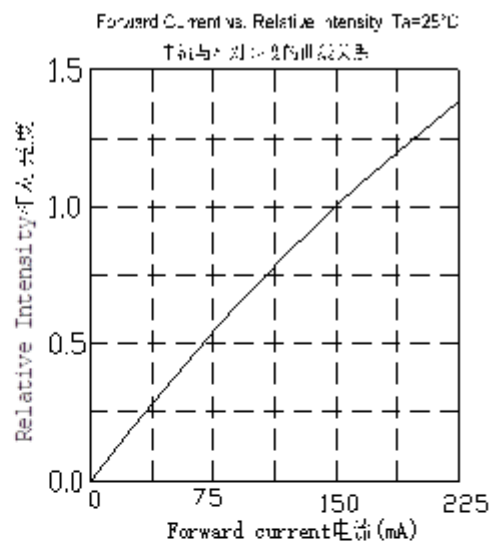
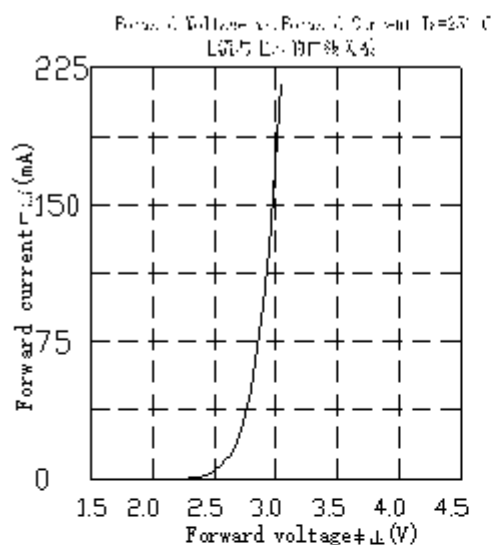

Curves of beam angle and relative brightness

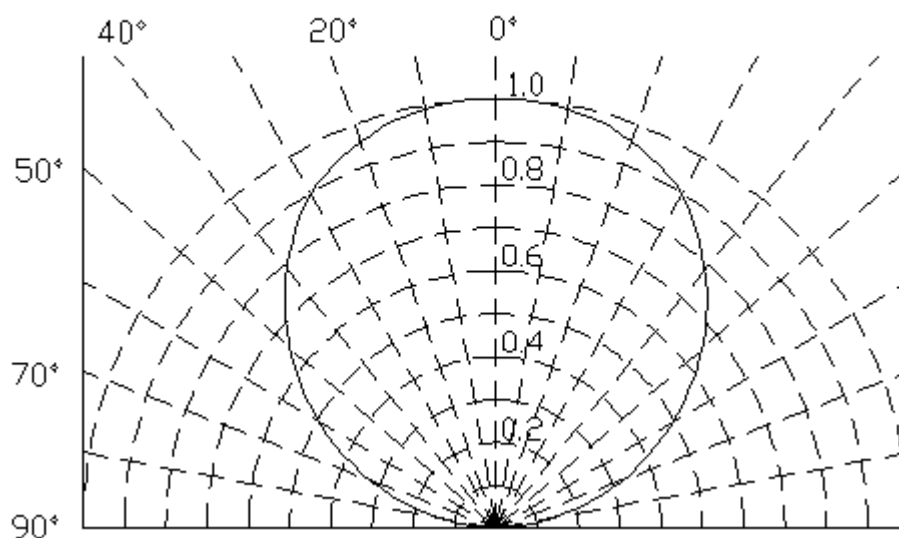

life test:

Affect of T_j on Luminous Maintenance
 (If=150mA)
 (Dot line: Expected Life)

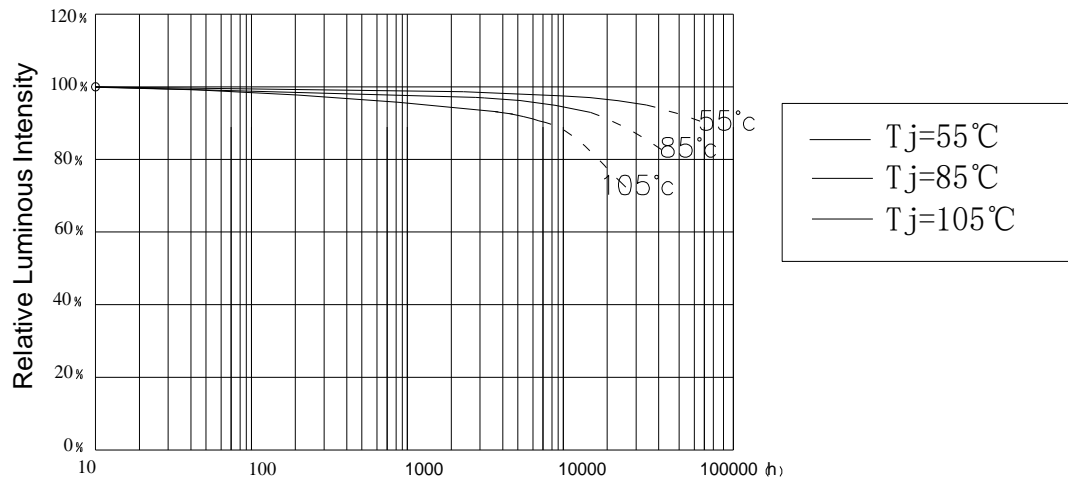

Mechanical Dimensions 外观尺寸: Unit 单位 (mm)

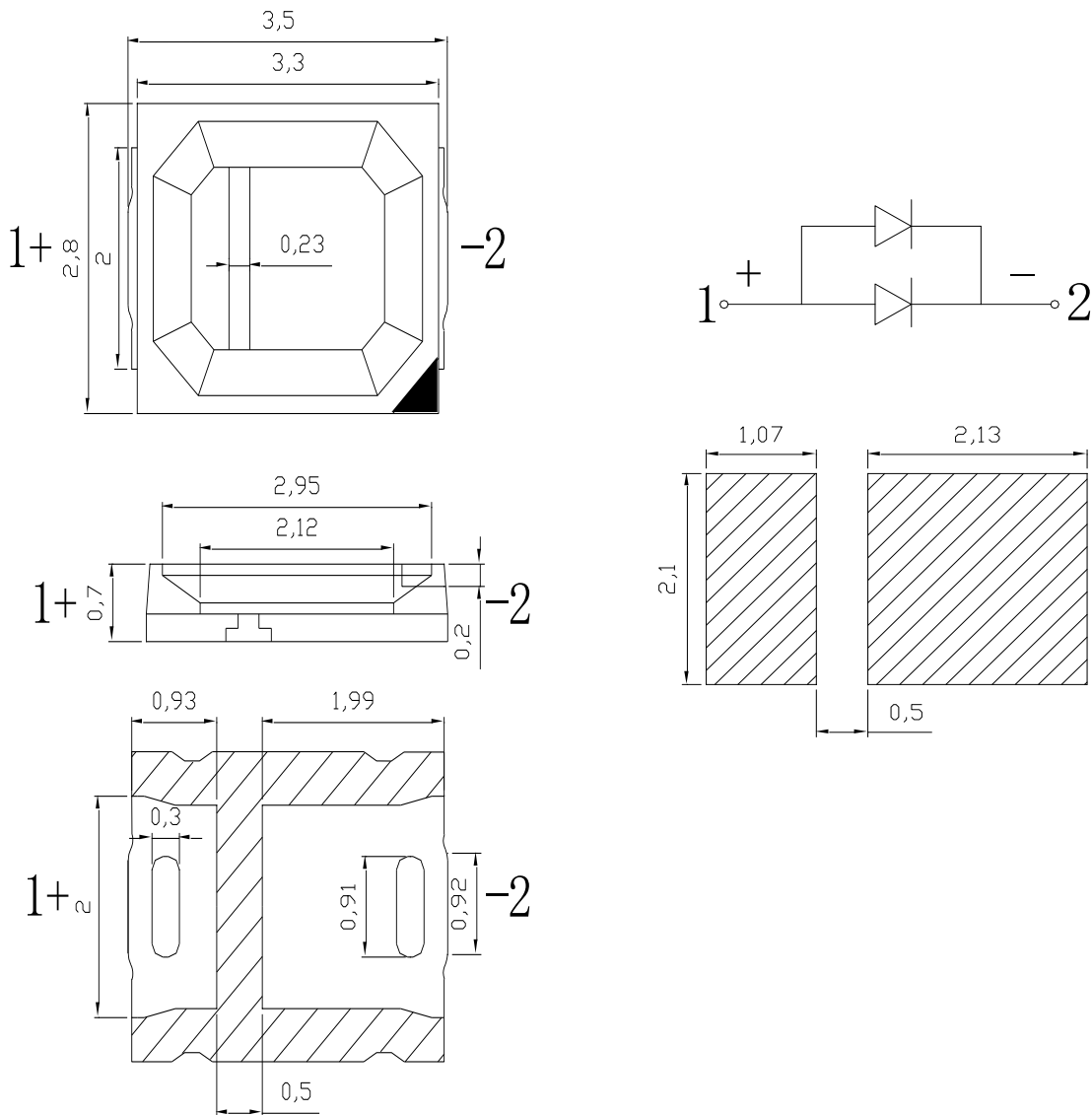

Product Bin and Labeling Definitions

Decoding Product Bin Labeling

In the manufacturing of semiconductor products, there are variations in performance around the average values given in the technical datasheet. For this reason, Lumileds bins LED components for luminous flux or radiometric power, color point, peak or dominant wavelength and forward voltage.

2835R Series LEDs are labeled using a 5-digit alphanumeric CAT code following the format below

Where:

A B C D E

A - designates luminous flux bin (example: B=95 to 100 lumens, G=140 to 150 lumens)

B C D - designates correlated color bin (example: A27, A30, A35, A40, A50, A57, A65)

E - designates forward voltage bin (example: B=34.5 to 35.0V, J=38.0 to 38.5V)

Therefore, a 2835R LED with a lumen range of 95 to 100, color bin of A35 and a forward voltage range of 38.0 to 38.5V has the following CAT code:

B A 3 5 J

Luminous Flux Bins

Luminous flux bin definitions for 2835R Series at rated current, Ta=25°C .

Product Number	Bin	Min	Max
L128-XX80RA35002F1	E	60	65
	F	65	70
	G	70	75

Notes

Lumileds Maintains a tolerance of ±5% on lumionous flux measurements

Color Bin Definition

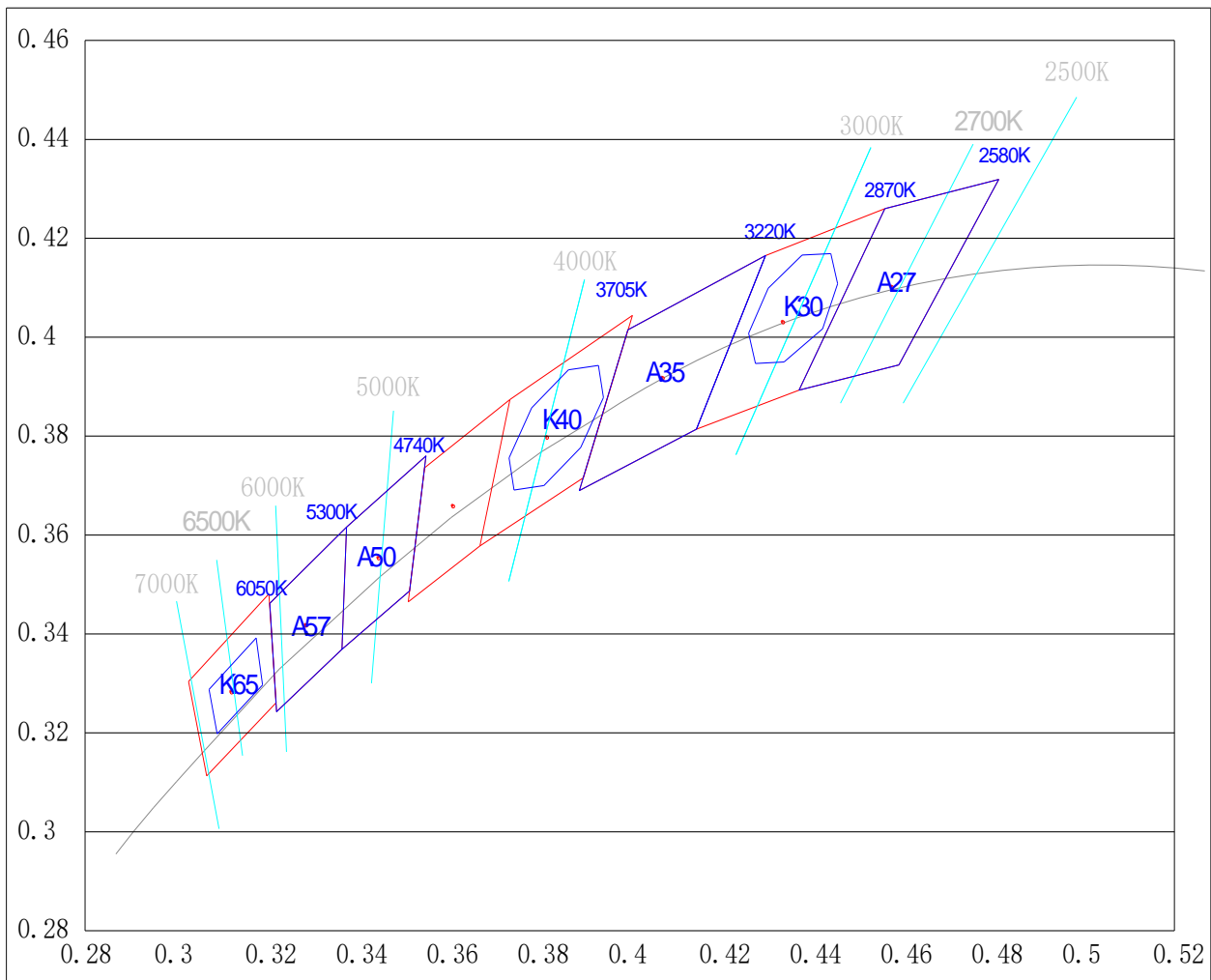

Correlated color temperature bin definitions for 2835R Series at rated current, Ta=25°C

2700K

Point	x	y
1	0.4813	0.4319
2	0.4562	0.426
3	0.4373	0.3893
4	0.4593	0.3944
Center	0.4578	0.4101

3000K

Point	x	y
1	0.4277	0.3947
2	0.4262	0.4008
3	0.4305	0.4099
4	0.438	0.4166
5	0.4443	0.4169
6	0.4458	0.4108
7	0.4425	0.4017
8	0.434	0.395
Center	0.436	0.4058

3500K

Point	x	y
1	0.4299	0.4165
2	0.3996	0.4015
3	0.3889	0.369
4	0.4147	0.3814
Center	0.4073	0.3917

4000K

Point	x	y
1	0.3745	0.3691
2	0.3734	0.3756
3	0.3784	0.3857
4	0.3865	0.3934
5	0.3931	0.3943
6	0.3942	0.3878
7	0.3892	0.3777
8	0.3811	0.37
Center	0.3838	0.3817

5000K

Point	x	y
1	0.3551	0.376
2	0.3376	0.3616
3	0.3366	0.3369
4	0.3515	0.3487
Center	0.3447	0.3553

5700K

Point	x	y
1	0.3376	0.3616
2	0.3207	0.3462
3	0.3222	0.3243
4	0.3366	0.3369
Center	0.3287	0.3417

6500K

Point	x	y
1	0.3091	0.3198
2	0.3073	0.3288
3	0.3177	0.3392
4	0.3191	0.3297
Center	0.3133	0.3394

Notes

Tester tolerance: ± 0.01 in x and y coordinates

Forward Voltage Bins

Forward voltage bin definitions for 2835R Series at rated current, $T_a=25^\circ\text{C}$.

Product Number	Bin	Min	Max
L128-XX80RA35002F1	C	2.8	2.9
	D	2.9	3.0
	E	3.0	3.1
	F	3.1	3.2

Requirements for application and reflow soldering 应用及回流焊要求:

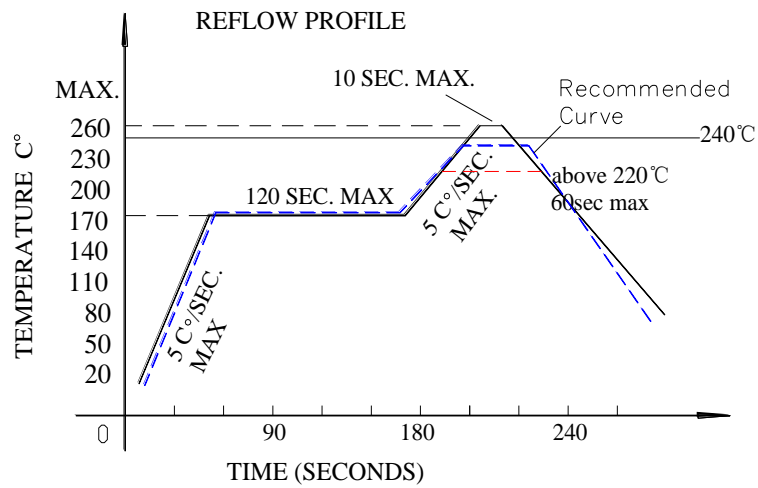

Reflow soldering curve 回流焊曲线图

(Product is highest resistant to 260°C reflow but suggested the highest temperature of 240°C within)

(产品最高可耐260°C回流焊，但建议最高温度设为240°C)

■ **Notes for reflow soldering** 回流焊注意事项:

1. No more than twice for reflow soldering.
注意回流焊不可超过两次。
2. To ensure the quality of our LEDs, we encapsulate them with silica gels. So please do not put pressure on the LEDs.
为保证产 LED 质量及可靠性我司采用硅胶封装，胶体表面较软，焊接加热过程中，不可施加压力在 LED 表面。
3. Please choose the right nozzle(try to learn from the plastic products parts) to avoid the damage to products due to the pressure.
在吸嘴的选取上要选择吸嘴的大小和压力合适的吸嘴（尽量吸取产品的塑胶部分），以避免造成压力过大伤害产品。
4. Please put on the antistatic hand loop during the use. The worktable should be with antistatic finish. The equipments must be contacted with ground.
LED 为静电敏感产品，使用时请佩带防静电手环，工作台做好防静电处理，机台设备等保证接地。

■ **Handwork soldering** 手工焊接:

1. During the soldering, the electronic soldering iron must be kept under the temperature of 300°C and the soldering time must not be beyond 3 seconds. No touch between the electronic soldering iron and colloid.
手工焊接时，要保持电烙铁温度在 300 摄氏度以下，并且焊接时间小于 3 秒，电烙铁不可接触胶体。
2. Handwork soldering is only allowed once. We won't take responsibility for more than that.
手工焊接只可进行一次，重复焊接不保证产品是否完好。
3. Avoid using sharp objects to compress products Colloidal Part directly.
避免使用尖锐的物体直接接触产品胶体部分。
4. Please put on the antistatic hand loop during the use. The worktable should be with antistatic finish. The equipments must be contacted with ground.
LED 为静电敏感产品，使用时请佩带防静电手环，工作台做好防静电处理，机台设备等保证接地。