

RE (CD287)

Features

- Long life of 1000-5000 hours at 105°C .
- High frequency, low impedance, high ripple current.
- Especially designed for LED driver.
- RoHS Compliant.

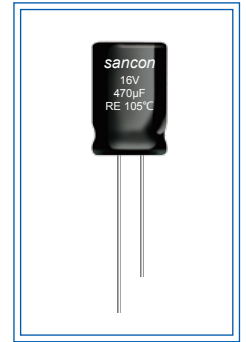

Specifications

Item	Performance Characteristics																											
Operating Temperature Range	-40~+105°C																											
Rated Voltage Range	6.3~100V																											
Nominal Capacitance Range	5.6~6800µF																											
Capacitance Tolerance	±20%(+20°C ,120Hz)																											
Leakage Current	$I \leq 0.01CV$ or $3\mu A$ (after 2 minutes , Whichever is greater)																											
Dissipation Factor ($tg\delta$, +20°C ,120Hz)	<table border="1"> <tr> <td>$U_R(V)$</td> <td>6.3</td> <td>10</td> <td>16</td> <td>25</td> <td>35</td> <td>50</td> <td>63</td> <td>100</td> </tr> <tr> <td>$tg\delta$</td> <td>0.22</td> <td>0.19</td> <td>0.16</td> <td>0.14</td> <td>0.12</td> <td>0.10</td> <td>0.09</td> <td>0.08</td> </tr> </table>	$U_R(V)$	6.3	10	16	25	35	50	63	100	$tg\delta$	0.22	0.19	0.16	0.14	0.12	0.10	0.09	0.08									
	$U_R(V)$	6.3	10	16	25	35	50	63	100																			
$tg\delta$	0.22	0.19	0.16	0.14	0.12	0.10	0.09	0.08																				
When rated capacitance is over 1000µF, $tg\delta$ shall be added 0.02 to the listed value with increase of every 1000µF.																												
Temperature Characteristics (Impedance ratio at 120Hz)	<table border="1"> <tr> <td>$U_R(V)$</td> <td>6.3</td> <td>10</td> <td>16</td> <td>25</td> <td>35</td> <td>50</td> <td>63</td> <td>100</td> </tr> <tr> <td>Z-25°C /+20°C</td> <td>4</td> <td>3</td> <td>2</td> <td>2</td> <td>2</td> <td>2</td> <td>2</td> <td>2</td> </tr> <tr> <td>Z-40°C /+20°C</td> <td>8</td> <td>6</td> <td>4</td> <td>3</td> <td>3</td> <td>3</td> <td>3</td> <td>3</td> </tr> </table>	$U_R(V)$	6.3	10	16	25	35	50	63	100	Z-25°C /+20°C	4	3	2	2	2	2	2	2	Z-40°C /+20°C	8	6	4	3	3	3	3	3
	$U_R(V)$	6.3	10	16	25	35	50	63	100																			
	Z-25°C /+20°C	4	3	2	2	2	2	2	2																			
Z-40°C /+20°C	8	6	4	3	3	3	3	3																				
Load Life	After applying rated voltage with specified ripple current for specified time at +105°C and then resumed 24hours: Capacitance change : ±25% of the initial measured value Leakage current : ≤ Initial specified value Dissipation factor: ≤ 200% of the initial specified value																											
	<table border="1"> <thead> <tr> <th rowspan="2">Case Size</th> <th>Life Time(hrs)</th> </tr> </thead> <tbody> <tr> <td>L=7</td> <td>1000</td> </tr> <tr> <td rowspan="4">L ≥ 11</td> <td>ΦD ≤ 6.3</td> <td>2000</td> </tr> <tr> <td>ΦD= 8</td> <td>3000</td> </tr> <tr> <td>ΦD= 10</td> <td>4000</td> </tr> <tr> <td>ΦD ≥ 12.5</td> <td>5000</td> </tr> </tbody> </table>	Case Size	Life Time(hrs)	L=7	1000	L ≥ 11	ΦD ≤ 6.3	2000	ΦD= 8	3000	ΦD= 10	4000	ΦD ≥ 12.5	5000														
Case Size	Life Time(hrs)																											
	L=7	1000																										
L ≥ 11	ΦD ≤ 6.3	2000																										
	ΦD= 8	3000																										
	ΦD= 10	4000																										
	ΦD ≥ 12.5	5000																										
Shelf Life	After storage for 1000 hours at +105°C , and then resumed 24 hours: Capacitance change : ±25% of the initial measured value Leakage current : ≤ 200% of the initial specified value Dissipation factor: ≤ 200% of the initial specified value																											

LED & Low Impedance

Diagram of Dimensions

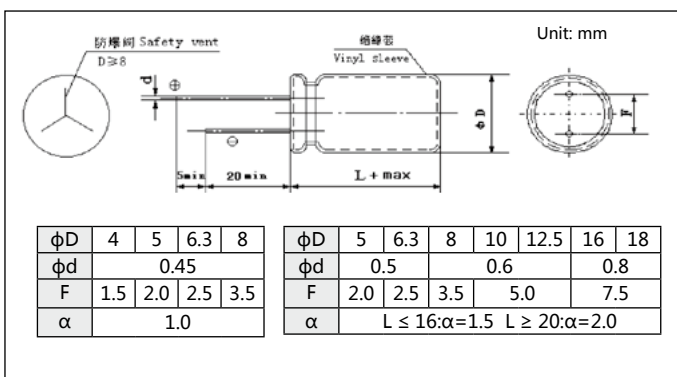

Multiplier for Ripple Current

Frequency coefficient		Frequency(Hz)			
Coefficient	5.6~33µF	0.42	0.70	0.90	1.00
	39~270µF	0.50	0.73	0.92	1.00
	330~680µF	0.55	0.77	0.94	1.00
	820~1800µF	0.60	0.80	0.96	1.00
	2200~6800µF	0.70	0.85	0.98	1.00

Temperature coefficient			
Temperature (°C)	+70	+85	+105
Coefficient	1.96	1.68	1.0

Standard Size

Rated Voltage (V _{dc})	Capacitance (μF)	Size ΦD×L (mm)	Rated ripple current (mA _{rms}) 105°C / 100KHz	Impedance (Ω MAX)	
				20°C, 100KHz	-10°C, 100KHz
6.3 (0J)	39	4×7	130	0.85	2.6
	68	5×7	210	0.43	1.3
	150	6.3×7	300	0.23	0.69
	150	5×11	250	0.30	1.0
	220	8×7	380	0.15	0.45
	330	6.3×11	405	0.13	0.41
	560	8×11.5	760	0.072	0.22
	820	8×16	995	0.056	0.17
	1000	10×12.5	1030	0.053	0.16
	1200	8×20	1250	0.041	0.13
	1200	10×16	1430	0.038	0.12
	1500	10×20	1820	0.023	0.069
	2200	10×23	2150	0.022	0.066
	3300	12.5×20	2360	0.021	0.053
	3900	12.5×25	2770	0.018	0.045
	4700	12.5×30	3290	0.016	0.041
	5600	12.5×35	3400	0.015	0.039
	5600	16×20	3140	0.018	0.045
6800	16×25	3460	0.016	0.043	
10 (1A)	27	4×7	130	0.89	2.7
	56	5×7	210	0.44	1.4
	100	5×11	250	0.30	1.0
	120	6.3×7	300	0.23	0.69
	180	8×7	380	0.15	0.45
	220	6.3×11	405	0.13	0.41
	470	8×11.5	760	0.072	0.22
	680	8×16	995	0.056	0.17
	680	10×12.5	1030	0.053	0.16
	1000	8×20	1250	0.041	0.13
	1000	10×16	1430	0.038	0.12
	1200	10×20	1820	0.023	0.069
	1500	10×23	2150	0.022	0.066
	2200	12.5×20	2360	0.021	0.053
	3300	12.5×25	2770	0.018	0.045
	3900	12.5×30	3290	0.016	0.041
	3900	16×20	3140	0.018	0.045
	4700	12.5×35	3400	0.015	0.039
5600	16×25	3460	0.016	0.043	
16 (1C)	18	4×7	130	0.92	2.8
	33	5×7	210	0.45	1.4
	56	5×11	250	0.30	1.0
	68	6.3×7	300	0.24	0.72
	120	8×7	380	0.15	0.45
	120	6.3×11	405	0.13	0.41
	330	8×11.5	760	0.072	0.22
	470	8×16	995	0.056	0.17
	470	10×12.5	1030	0.053	0.16
	680	8×20	1250	0.041	0.13
	680	10×16	1430	0.038	0.12
	1000	10×20	1820	0.023	0.069
	1200	10×23	2150	0.022	0.066
	1500	12.5×20	2360	0.021	0.053
	2200	12.5×25	2770	0.018	0.045
	2700	12.5×30	3290	0.016	0.041
	2700	16×20	3140	0.018	0.045
	3300	12.5×35	3400	0.015	0.039
3900	16×25	3460	0.016	0.043	

Rated Voltage (V _{dc})	Capacitance (μF)	Size ΦD×L (mm)	Rated ripple current (mA _{rms}) 105°C / 100KHz	Impedance (Ω MAX)		
				20°C, 100KHz	-10°C, 100KHz	
25 (1E)	15	4×7	130	0.94	2.9	
	27	5×7	210	0.46	1.4	
	47	5×11	250	0.30	1.0	
	56	6.3×7	300	0.24	0.72	
	100	8×7	380	0.15	0.45	
	100	6.3×11	405	0.13	0.41	
	220	8×11.5	760	0.072	0.22	
	330	8×16	995	0.056	0.17	
	330	10×12.5	1030	0.053	0.16	
	470	8×20	1250	0.041	0.13	
	470	10×16	1430	0.038	0.12	
	680	10×20	1820	0.023	0.069	
	820	10×23	2150	0.022	0.066	
	1000	12.5×20	2360	0.021	0.053	
	1500	12.5×25	2770	0.018	0.045	
	1800	12.5×30	3290	0.016	0.041	
	1800	16×20	3140	0.018	0.045	
	2200	12.5×35	3400	0.015	0.039	
	2700	16×25	3460	0.016	0.043	
	35 (1V)	10	4×7	130	0.96	2.9
		18	5×7	210	0.47	1.5
33		5×11	250	0.30	1.0	
39		6.3×7	300	0.25	0.75	
56		8×7	380	0.16	0.48	
56		6.3×11	405	0.13	0.41	
150		8×11.5	760	0.072	0.22	
220		8×16	995	0.056	0.17	
220		10×12.5	1030	0.053	0.16	
270		8×20	1250	0.041	0.13	
330		10×16	1430	0.038	0.12	
470		10×20	1820	0.023	0.069	
560		10×23	2150	0.022	0.066	
680		12.5×20	2360	0.021	0.053	
1000		12.5×25	2770	0.018	0.045	
1200		12.5×30	3290	0.016	0.041	
1200		16×20	3140	0.018	0.045	
1500		12.5×35	3400	0.015	0.039	
1800	16×25	3460	0.016	0.043		
50 (1H)	5.6	4×7	130	1.0	3.0	
	10	5×7	210	0.50	1.5	
	22	6.3×7	300	0.26	0.78	
	22	5×11	238	0.34	1.18	
	33	8×7	380	0.17	0.51	
	56	6.3×11	385	0.14	0.50	
	100	8×11.5	724	0.074	0.22	
	120	8×16	950	0.061	0.18	
	150	10×12.5	979	0.061	0.18	
	180	8×20	1190	0.046	0.14	
	220	10×16	1370	0.042	0.12	
	270	10×20	1580	0.030	0.090	
	330	10×23	1870	0.028	0.085	
	470	12.5×20	2050	0.027	0.068	
	560	12.5×25	2410	0.023	0.059	
	680	12.5×30	2860	0.021	0.052	
	820	12.5×35	2960	0.019	0.051	
	820	16×20	2730	0.023	0.059	
	1000	16×25	3010	0.021	0.056	

LED & Low Impedance

Standard Size

Rated Voltage (V _{dc})	Capacitance (μF)	Size ΦD×L (mm)	Rated ripple current (mA _{rms}) 105°C / 100KHz	Impedance (Ω MAX)	
				20°C, 100KHz	-10°C, 100KHz
63 (1J)	15	5×11	165	0.88	3.5
	33	6.3×11	265	0.35	1.4
	56	8×11.5	500	0.22	0.88
	82	8×16	665	0.16	0.64
	82	10×12.5	685	0.15	0.60
	120	8×20	820	0.12	0.48
	120	10×16	945	0.11	0.44
	180	10×20	1100	0.080	0.32
	180	12.5×16	1135	0.082	0.27
	220	10×23	1300	0.073	0.29
	270	12.5×20	1495	0.060	0.20
	330	12.5×25	1850	0.043	0.14
	470	12.5×30	2250	0.039	0.13
	470	16×20	1990	0.045	0.14
	560	12.5×35	2450	0.033	0.11
	560	16×25	2550	0.032	0.096
	680	12.5×40	2780	0.029	0.096
	680	18×20	2450	0.038	0.10
	820	16×31.5	2810	0.026	0.078
	820	18×25	2780	0.031	0.084
1000	16×35.5	2835	0.021	0.063	
1000	18×31.5	3270	0.025	0.068	
1200	16×40	3340	0.019	0.057	
1200	18×35.5	3310	0.020	0.054	
1500	18×40	3420	0.018	0.049	

Rated Voltage (V _{dc})	Capacitance (μF)	Size ΦD×L (mm)	Rated ripple current (mA _{rms}) 105°C / 100KHz	Impedance (Ω MAX)	
				20°C, 100KHz	-10°C, 100KHz
100 (2A)	6.8	5×11	125	1.40	5.6
	15	6.3×11	205	0.57	2.3
	27	8×11.5	355	0.36	1.4
	39	8×16	450	0.25	1.0
	47	10×12.5	450	0.24	0.96
	56	8×20	565	0.19	0.76
	68	10×16	580	0.18	0.72
	82	10×20	750	0.13	0.52
	82	12.5×16	735	0.13	0.43
	100	10×23	880	0.12	0.48
	120	12.5×20	1045	0.094	0.31
	180	12.5×25	1195	0.071	0.23
	220	12.5×30	1410	0.063	0.21
	220	16×20	1295	0.071	0.21
	270	12.5×35	1560	0.052	0.17
	270	16×25	1600	0.053	0.16
	270	18×20	1470	0.069	0.19
	330	12.5×40	1700	0.046	0.15
	390	16×31.5	1750	0.041	0.12
	390	18×25	1620	0.049	0.13
	470	16×35.5	1890	0.033	0.10
	470	18×31.5	1775	0.039	0.11
	560	16×40	2080	0.030	0.090
	560	18×35.5	2060	0.031	0.084
	680	18×40	2570	0.028	0.076

LED & Low Impedance