

## Features

- Ultra High Efficiency (Up to 91%)
- Active Power Factor Correction (0.99 Typical)
- Constant Current Output
- Lightning Protection
- All-Round Protection: SCP, OTP, OVP
- Waterproof (IP67)
- Comply With UL8750 & EN61347 Safety Regulations



## Description

The EUC-100SxxxDT (ST) Series operate from a 90 ~ 305 Vac input range. These units will provide up to a 4.2 A of output current and a maximum output voltage of 286 V for 100 W maximum output power. They are designed to be highly efficient and highly reliable. The standard features include dimming control, lightning protection, over voltage protection, short circuit protection, and over temperature protection.

## Models

Output Current	Input Voltage	Max. Output Voltage	Max. Output Power	Typical Efficiency (1)	Power Factor		Model Number (2)
					110Vac	220Vac	
350 mA	90 ~ 305 Vac	286 Vdc	100 W	91.0%	0.99	0.96	EUC-100S035DT(ST)★
450 mA	90 ~ 305 Vac	222 Vdc	100 W	91.0%	0.99	0.96	EUC-100S045DT(ST)★
700 mA	90 ~ 305 Vac	143 Vdc	100 W	90.5%	0.99	0.96	EUC-100S070DT(ST)★
1050 mA	90 ~ 305 Vac	95 Vdc	100 W	90.5%	0.99	0.96	EUC-100S105DT(ST)★
1400 mA	90 ~ 305 Vac	71 Vdc	100 W	90.5%	0.99	0.96	EUC-100S140DT(ST)
1750 mA	90 ~ 305 Vac	57 Vdc	100 W	90.5%	0.99	0.96	EUC-100S175DT(ST)
2100 mA	90 ~ 305 Vac	48 Vdc	100 W	90.5%	0.99	0.96	EUC-100S210DT(ST)★
2450 mA	90 ~ 305 Vac	41 Vdc	100 W	90.5%	0.99	0.96	EUC-100S245DT(ST)★
2800 mA	90 ~ 305 Vac	36 Vdc	100 W	90.0%	0.99	0.96	EUC-100S280DT(ST)
3150 mA	90 ~ 305 Vac	32 Vdc	100 W	90.0%	0.99	0.96	EUC-100S315DT(ST)★
3570 mA	90 ~ 305 Vac	28 Vdc	100 W	90.0%	0.99	0.96	EUC-100S357DT(ST)
4200 mA	90 ~ 305 Vac	24 Vdc	100 W	90.0%	0.99	0.96	EUC-100S420DT(ST)

- Notes:**
- (1) Measured at full load and 220 Vac input.
  - (2) A suffix -xxx may be added to denote variations or modifications to the base product, where x can be any alphanumeric character or blank.
  - (3) ★: Popular model.

Specifications are subject to changes without notice.

## Input Specifications

Parameter	Min.	Typ.	Max.	Notes
Input Voltage	90 V	-	305 V	
Input Frequency	47 Hz	-	63 Hz	
Leakage Current	-	-	1 mA	At 277Vac 50Hz input
Input AC Current	-	-	1.3 A	Measured at full load and 100 Vac input.
	-	-	0.6 A	Measured at full load and 220 Vac input.
Inrush current	-	-	65 A	At 230Vac input 25°C Cold start

## Output Specifications

Parameter	Min.	Typ.	Max.	Notes
Output Current Range				Without dimming
$I_o = 350 \text{ mA}$	332 mA	350 mA	368 mA	
$I_o = 450 \text{ mA}$	427 mA	450 mA	473 mA	
$I_o = 700 \text{ mA}$	665 mA	700 mA	735 mA	
$I_o = 1050 \text{ mA}$	997 mA	1050 mA	1102 mA	
$I_o = 1400 \text{ mA}$	1330 mA	1400 mA	1470 mA	
$I_o = 1750 \text{ mA}$	1662 mA	1750 mA	1837 mA	
$I_o = 2100 \text{ mA}$	1995 mA	2100 mA	2205 mA	
$I_o = 2450 \text{ mA}$	2327 mA	2450 mA	2572 mA	
$I_o = 2800 \text{ mA}$	2660 mA	2800 mA	2940 mA	
$I_o = 3150 \text{ mA}$	2992 mA	3150 mA	3307 mA	
$I_o = 3570 \text{ mA}$	3391 mA	3570 mA	3748 mA	
$I_o = 4200 \text{ mA}$	3990 mA	4200 mA	4410 mA	
Output Voltage Range				
$I_o = 350 \text{ mA}$	172 V	-	286 V	
$I_o = 450 \text{ mA}$	132 V	-	222 V	
$I_o = 700 \text{ mA}$	86 V	-	143 V	
$I_o = 1050 \text{ mA}$	57 V	-	95 V	
$I_o = 1400 \text{ mA}$	43 V	-	71 V	
$I_o = 1750 \text{ mA}$	34 V	-	57 V	
$I_o = 2100 \text{ mA}$	29 V	-	48 V	
$I_o = 2450 \text{ mA}$	25 V	-	41 V	
$I_o = 2800 \text{ mA}$	22 V	-	36 V	
$I_o = 3150 \text{ mA}$	19 V	-	32 V	
$I_o = 3570 \text{ mA}$	17 V	-	28 V	
$I_o = 4200 \text{ mA}$	14 V	-	24 V	
Ripple and Noise (pk-pk)	-	-	3% $V_o$	Measured by 20 MHz bandwidth (ST)h oscilloscope and the output paralleled a 0.1 $\mu\text{F}$ ceramic capacitor and a 10 $\mu\text{F}$ electrolytic capacitor.
Line Regulation	-	-	1%	
Load Regulation	-	-	3%	
Turn-on Delay Time	-	0.6 s	1.0 s	Measured at 110Vac input.
	-	0.6 s	1.0 s	Measured at 220Vac input.

**Note:** All specifications are typical at 25 °C unless otherwise stated.

Specifications are subject to changes without notice.

## Protection Functions

Parameter	Min.	Typ.	Max.	Notes
Over Voltage Protection				Latch mode. The power supply shall return to normal operation only after the power is turn-on again.
$I_o = 350$ mA	343 V	372 V	401 V	
$I_o = 450$ mA	266 V	289 V	311 V	
$I_o = 700$ mA	171 V	186 V	200 V	
$I_o = 1050$ mA	114 V	124 V	133 V	
$I_o = 1400$ mA	86 V	94 V	101 V	
$I_o = 1750$ mA	68 V	74 V	80 V	
$I_o = 2100$ mA	57 V	63 V	67 V	
$I_o = 2450$ mA	49 V	53 V	58 V	
$I_o = 2800$ mA	43 V	47 V	51 V	
$I_o = 3150$ mA	38 V	42 V	45 V	
$I_o = 3570$ mA	33 V	36 V	40 V	
$I_o = 4200$ mA	28V	31 V	34 V	
Over Temperature Protection	-	110 °C	-	Maximum temperature of components inside the case.
Short Circuit Protection	No damage shall occur when any output operating in a short circuit condition. The power supply shall be self-recovery when the fault condition is removed.			

## General Specifications

Parameter	Min.	Typ.	Max.	Notes
Efficiency				Measured at full load, 110Vac input, 25°C ambient temperature, after the unit is thermally stabilized.  It will be lower about 1%, if measured immediately after startup.
$I_o = 350$ mA	88.0%	89.0%	-	
$I_o = 450$ mA	88.0%	89.0%	-	
$I_o = 700$ mA	87.5%	88.5%	-	
$I_o = 1050$ mA	87.5%	88.5%	-	
$I_o = 1400$ mA	87.5%	88.5%	-	
$I_o = 1750$ mA	87.5%	88.5%	-	
$I_o = 2100$ mA	87.5%	88.5%	-	
$I_o = 2450$ mA	87.5%	88.5%	-	
$I_o = 2800$ mA	87.0%	88.0%	-	
$I_o = 3150$ mA	87.0%	88.0%	-	
$I_o = 3570$ mA	87.0%	88.0%	-	
$I_o = 4200$ mA	87.0%	88.0%	-	
Efficiency				Measured at full load, 220Vac input, 25°C ambient temperature, after the unit is thermally stabilized.  It will be lower about 1%, if measured immediately after startup.
$I_o = 350$ mA	90.0%	91.0%	-	
$I_o = 450$ mA	90.0%	91.0%	-	
$I_o = 700$ mA	89.5%	90.5%	-	
$I_o = 1050$ mA	89.5%	90.5%	-	
$I_o = 1400$ mA	89.5%	90.5%	-	
$I_o = 1750$ mA	89.5%	90.5%	-	
$I_o = 2100$ mA	89.5%	90.5%	-	
$I_o = 2450$ mA	89.5%	90.5%	-	
$I_o = 2800$ mA	89.0%	90.0%	-	
$I_o = 3150$ mA	89.0%	90.0%	-	
$I_o = 3570$ mA	89.0%	90.0%	-	
$I_o = 4200$ mA	89.0%	90.0%	-	
MTBF				Measured at 110Vac input, 80%Load and 25°C ambient temperature (MIL-HDBK-217F)
$I_o = 4200$ mA		235,000 hours		
$I_o = 350$ mA		394,000 hours		
Life Time				Measured at 220Vac input, 80%Load and 45°C ambient temperature
$I_o = 4200$ mA		91,000 hours		
$I_o = 350$ mA		118,000 hours		
Dimensions				
Inches (L x W x H)		7.64 x 2.66 x 1.46		
Millimeters (L x W x H)		194 x 67.5 x 37		
Net Weight	-	1000 g	-	

**Note:** All specifications are typical at 25 °C unless otherwise stated.

*Specifications are subject to changes without notice.*

## Environmental Specifications

Parameter	Min.	Typ.	Max.	Notes
Operating Temperature	-35 °C	-	+65 °C	Humidity: 10% RH to 100% RH
Storage Temperature	-40 °C	-	+85 °C	Humidity: 5% RH to 100% RH

## Safety & EMC Compliance

Safety Category	Standard
CUL	UL8750, UL935, UL1012, CSA-C22.2 No. 107.1
CE	EN 61347-1, EN61347-2-13
EMI Standards	Notes
EN 55015	Conducted emission Test & Radiated emission Test with 6 dB margin
EMS Standards	Notes
EN 61000-3-2	Harmonic current emissions
EN 61000-3-3	Voltage fluctuations & flicker
EN 61000-4-2	Electrostatic Discharge (ESD): 8 kV air discharge, 4 kV contact discharge
EN 61000-4-3	Radio-Frequency Electromagnetic Field Susceptibility Test-RS
EN 61000-4-4	Electrical Fast Transient / Burst-EFT
EN 61000-4-5	Surge Immunity Test: AC Power Line: line to line 2 kV, line to earth 4 kV
EN 61000-4-6	Conducted Radio Frequency Disturbances Test-CS
EN 61000-4-8	Power Frequency Magnetic Field Test
EN 61000-4-11	Voltage Dips
EN 61547	Electromagnetic Immunity Requirements Applies To Lighting Equipment

## Derating Curve

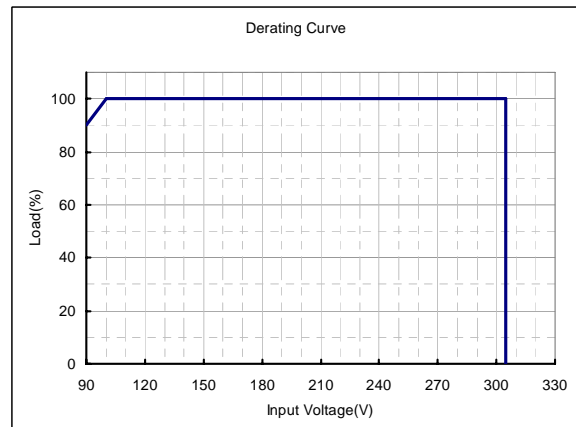
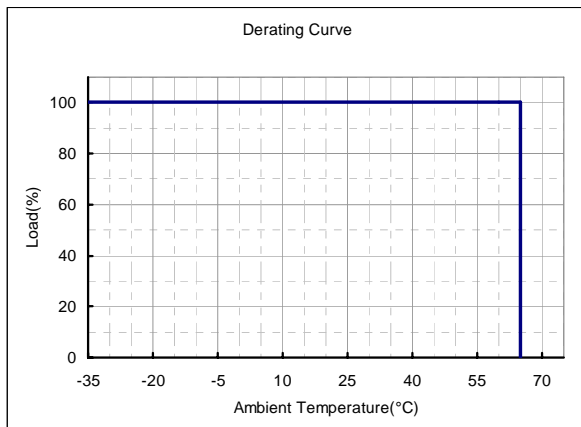

Specifications are subject to changes without notice.

## Dimming Control (On Secondary Side)

The function has two versions. One is with internal pull-up resistor; the output is full load when the dimming leads are floated. Another is with internal pull-down resistor; the output is 10% full load when the dimming leads are floated.

1. With pull-up resistor (Default, without suffix):

Parameter	Min.	Typ.	Max.	Notes
Vcc	9.5 V	10 V	10.5 V	
10V output source current	0 mA	-	10 mA	
Absolute maximum voltage on the 1~10V input pin	-2 V	-	12 V	
Source current on 1~10V input pin	0 mA	-	0.5 mA	
Value of Rin ( the resistor inside the LED driver which locate between the 1-10V input and 10V output pin)	19.8 K	20 K	20.2 K	

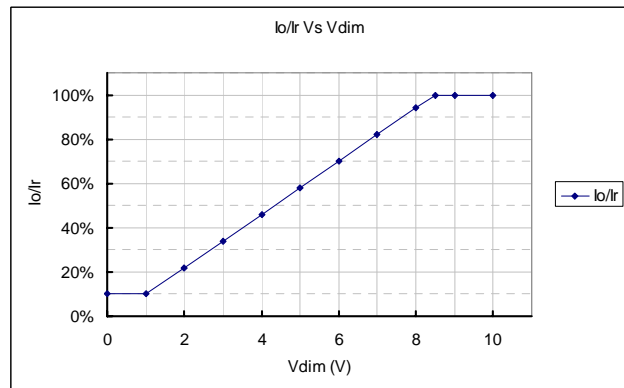
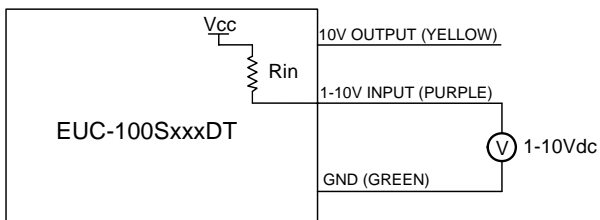

Implementation 1: DC input

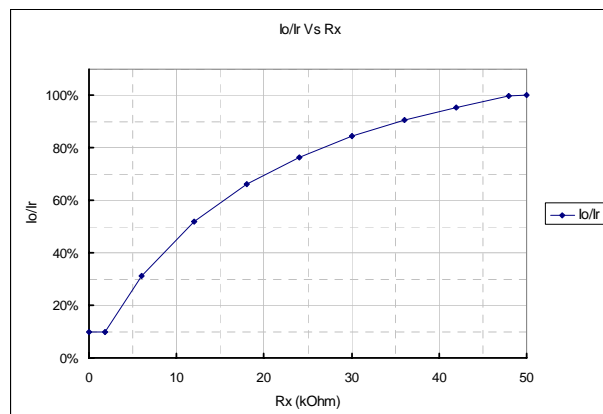
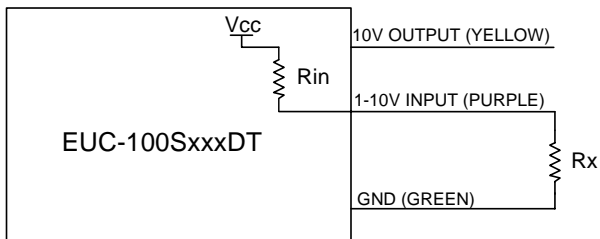

Implementation 2: External resistor

## Dimming Control (Continued)

### Notes:

1. If the dimming function is not used, please let the dimming leads floated.
2.  $I_o$  is actual output current and  $I_r$  is rated current without dimming control.
3. For the driver to operate properly, the load voltage must be maintained above the minimum voltage threshold (approx. 50% of the max. output voltage for any given model).
4. If the output voltage is maintained above 50% of the maximum output voltage, the dimming control may be operated over the entire 1-10V range with output current varying from 100% down to practically 10%.
5. The dimming signal is allowed to be less than 1V, however, when it for 0-1V, the output current can maintain about 10% $I_r$ . When it for 8.5-10V, the output current can maintain about 100% $I_r$ .
6. Do not connect the GND of dimming to the output; otherwise, the LED driver can not work normally.

2. With pull-down resistor: (The model number has a suffix -0040)

Parameter	Min.	Typ.	Max.	Notes
10V output voltage	9.5 V	10 V	10.5 V	
10V output source current	0 mA	-	10 mA	
Absolute maximum voltage on the 1~10V input pin	-2 V	-	12 V	
Sink current on 1~10V input pin	0 mA	-	1 mA	
Value of $R_{in}$ ( the resistor inside the LED driver which locate between the 1-10V input and GND)	9.9 K	10 K	10.1 K	

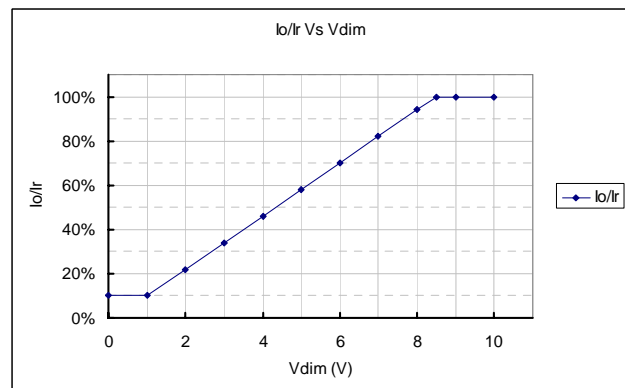
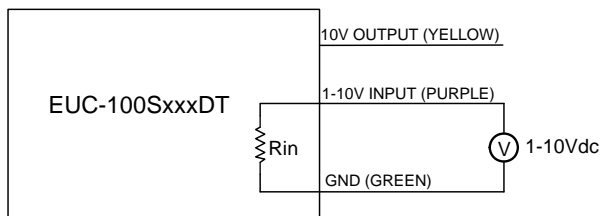

Implementation 1: DC input

## Dimming Control (Continued)

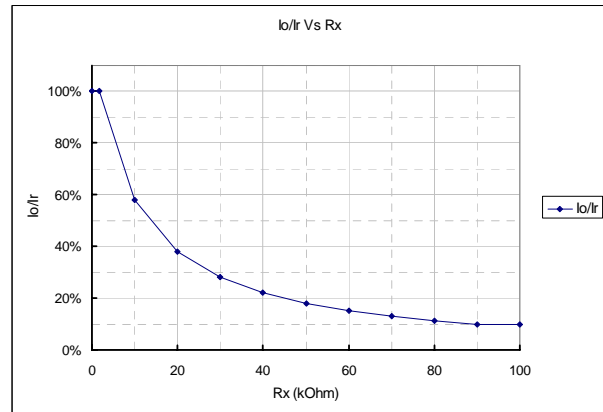
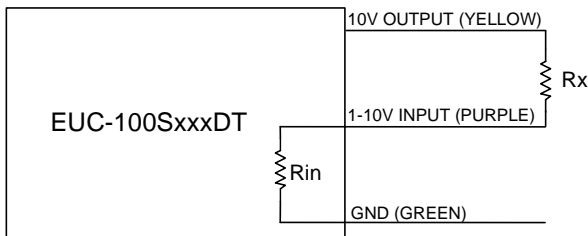

### Implementation 2: External resistor

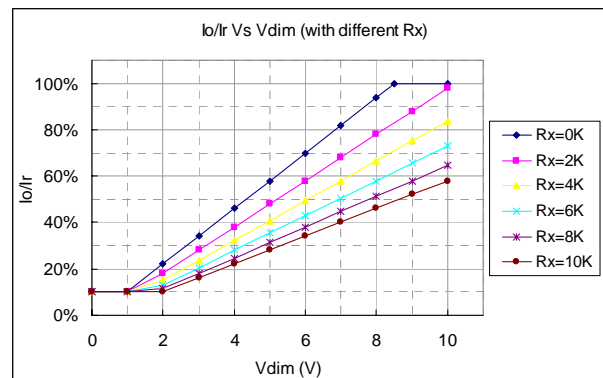
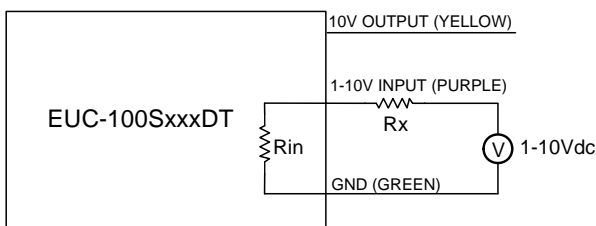

### Implementation 3: External resistor and 1-10V DC Input

#### Notes:

1. If the dimming function is not used, please short 10V output pin (yellow) and 1-10 input pin (purple).
2.  $I_o$  is actual output current and  $I_r$  is rated current without dimming control.
3. For the driver to operate properly, the load voltage must be maintained above the minimum voltage threshold (approx. 50% of the max. output voltage for any given model).
4. If the output voltage is maintained above 50% of the maximum output voltage, the dimming control may be operated over the entire 1-10V range with output current varying from 100% down to practically 10%.
5. The dimming signal is allowed to be less than 1V, however, when it for 0-1V, the output current can maintain about 10% $I_r$ . When it for 8.5-10V, the output current can maintain about 100% $I_r$ .
6. Do not connect the GND of dimming to the output; otherwise, the LED driver can not work normally.

## Mechanical Outline

### EUC-100SxxxDT

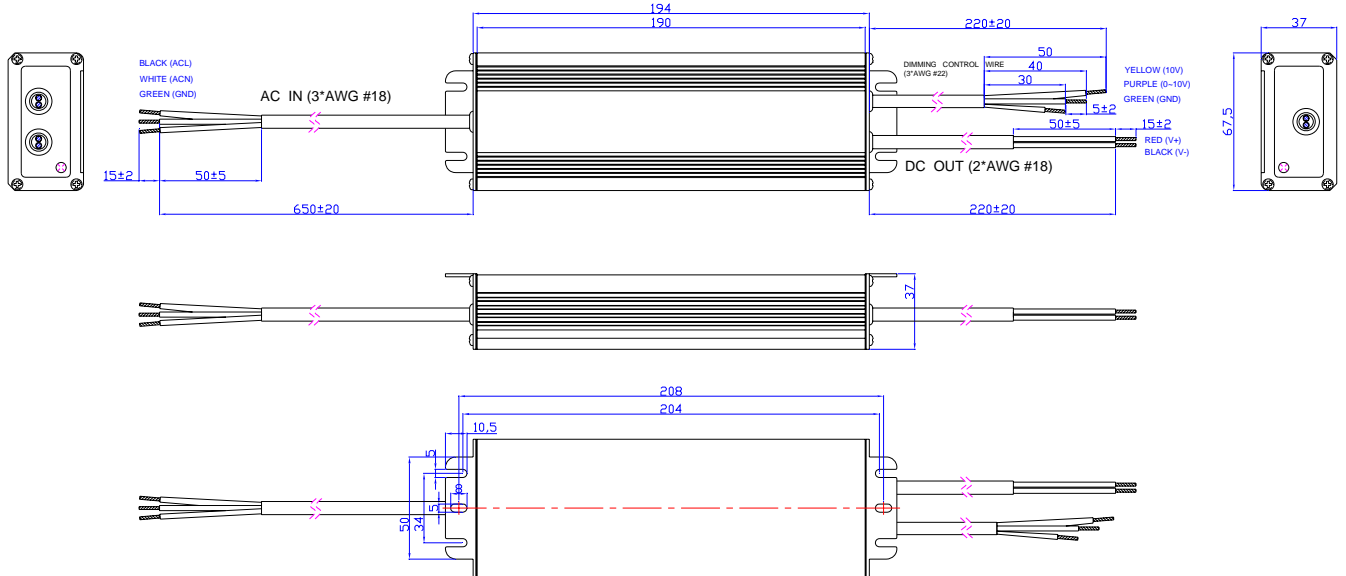

### EUC-100SxxxST

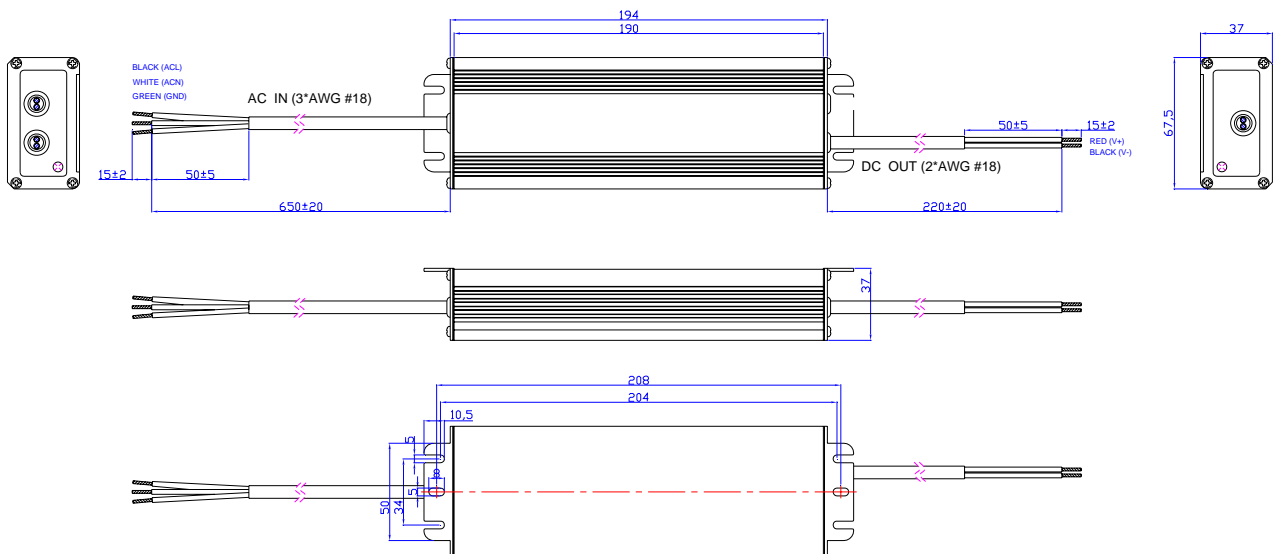

## RoHS Compliance

Our products comply with the European Directive 2002/95/EC, calling for the elimination of lead and other hazardous substances from electronic products.

Specifications are subject to changes without notice.

## Revision History

Change Date	Rev.	Description of Change		
		Item	From	To
2009-09-15	V2.0	Change output voltage range		
2009-10-27	V2.1	Change the Min. Output Voltage		
2009-12-02	V2.2	Change the efficiency and output voltage range		
2010-03-23	A	Add Leakage Current in Input Specifications	/	Max. 1 mA At 277Vac 50Hz input
		Change the Max. value of Operating Temperature	+70 °C	+65 °C
		Change the Max. Ambient Temperature in Derating Curve	+70 °C	+65 °C
		Change the MTBF data and testing condition	450,000 hours / Measured at EUC-100S140DT(ST)	350,000 hours / Measured at EUC-100S105DT(ST)
		Change the Life Time testing condition	Measured at EUC-100S140DT(ST)	Measured at EUC-100S105DT(ST)
		Add one note in Dimming Control	/	7. Do not connect the GND of dimming to the output; otherwise, the LED driver can not work normally.
		Change the dimming control line in Mechanical Outline	/	/
2010-05-31	B	Add star rank for recommended models	/	☆: Popular model.
2010-10-22	C	Update the part of dimming control	/	/
2010-10-18	D	Add another dimming version with pull-down resistor	/	/
2011-01-14	E	Change popular models	/	/
		Update MTBF & Life Time Date	For One Model	For Two Models
2011-09-07	F	Dimming Control	/	/

Specifications are subject to changes without notice.